

**MARKING SCHEME
CLASS X – DELHI**

Code No. 31/1/3

	Expected Answer/ Value point	Marks	Total
SECTION – A			
Q 1.	C ₄ H ₁₀ ; C ₆ H ₁₄	½, ½	1
Q2.	Each piece regenerates into a new Planaria.	1	1
Q3.	Because the green plants prepare food by photosynthesis by using solar energy.	1	1
Q4.	• Ability of lens to converge or diverge the light rays.	½	2
	• +ve sign → converging lens/ convex lens		
	–ve sign → diverging lens/ concave lens	½	
	• S.I. unit – dioptre 1 dioptre = 1/ focal length (m)	½	
Q5.	Advantages of watershed management – (i) mitigates drought and floods (ii) increase the life of the dams and reservoirs downstream (iii) increases the biomass production and thereby the income of the watershed community. (iv) helps in maintaining ecological balance by scientific conservation of soil and water. or any other	(Any four) 4 x ½	2
Q6.	Reuse refers to the use of the same material again and again.	½	2
	In reuse of materials no energy is consumed and the resources are saved.	½	
	In recycling certain used materials are converted into other useful materials.	½	
	In recycling of materials, energy is consumed and the resources may be wasted	½	
Q7.	• Ethene		2
	• $\text{C}_2\text{H}_5\text{OH} \xrightarrow[443\text{K}]{\text{Conc. H}_2\text{SO}_4 + \text{Heat}} \text{H}_2\text{C} = \text{CH}_2 + \text{H}_2\text{O}$ ethene		
	• Conc. H ₂ SO ₄ acts as a dehydrating agent/ removes water from the reactant		
	• Ethane/ C ₂ H ₆ will be formed	½ x 4	
Q8.	(i) Esters	½	3
	<u>Chemical equation –</u> $\text{CH}_3 - \overset{\text{O}}{\parallel}{\text{C}} - \text{OH} + \text{CH}_3\text{CH}_2\text{OH} \xrightarrow{\text{Conc. H}_2\text{SO}_4} \text{CH}_3 - \overset{\text{O}}{\parallel}{\text{C}} - \text{O} - \text{CH}_2 - \text{CH}_3 + \text{H}_2\text{O}$	1	
	Product's chemical name – Ethyl ethanoate	½	
(ii)	Conc. H ₂ SO ₄ acts as a dehydrating agent (Helps in the removal of water formed in the reaction)	1	

Q9.	Characteristics	A	B		
(a)	Number of electrons in their atoms	4 or 12 or 20	5 or 13 or 21		
(b)	Size of their atoms	Bigger	Smaller		
(c)	Their tendencies to lose electrons	More	Less		
(d)	The formula of their oxides	AO	B ₂ O ₃		
(e)	Their metallic character	More metallic	Less metallic		
(f)	The formula of their chlorides	ACl ₂	BCl ₃	6 x ½	3
Q10.	<ul style="list-style-type: none"> The electronic configuration (2, 8, 2) of the element 'M' suggests that it belongs to group 2 and period 3 of the Modern Periodic Table and its valency is 2. The chemical formula of the compounds are – 			½+½	
	M (NO ₃) ₂ / Mg (NO ₃) ₂ ; MSO ₄ / MgSO ₄ ; M ₃ (PO ₄) ₂ / Mg ₃ (PO ₄) ₂ .			3x½	
	'M' will form ionic compounds by losing two electrons.			½	3
Q11.	<p>Pollination – The transfer of pollen grains from the anther to the stigma is called pollination.</p> <p>The two types of pollination :</p> <p>Self pollination – When the pollen grains from the stamens of a flower fall on the stigma of the same flower, then self pollination occurs.</p> <p>Cross pollination – When pollen grains from the stamens of a flower fall on the stigma of another flower, then cross pollination occurs.</p>			1	
				½, ½	
				½, ½	3
Q12	<p>Three methods of contraception –</p> <p>(i) Barrier method or mechanical method/ Condom/ Diaphragm, to prevent the meeting of sperms and ova.</p> <p>(ii) Chemical method/ Oral pills, Changes the hormonal balance of the female partner so that the eggs are not released.</p> <p>(iii) Surgical method – to block the vasdeferens in males/ vasectomy or the fallopian tube (oviduct) in females/ tubectomy, to prevent the transfer of sperms or egg and hence no fertilization takes place.</p> <p>(iv) IUCDs/ Loop or the copper-T placed in the uterus, to prevent pregnancy</p>			3x (½+½)	
	(Any three)			½)	3
Q13.	<p>A Anther – it produces pollen grains</p> <p>B Style – it provides the path through which the Pollen tube grows and reaches the ovary</p> <p>C Ovary – it contains ovules and each ovule has an egg cell/ female gamete. It develops into fruit after fertilization.</p>			½, ½	
				½, ½	
				½, ½	3
Q14.	<p>Yes, the scientist may arrive at the law of dominance according to which the trait that is expressed in the F₁ generation is the dominant trait, although both the dominant and recessive traits are present in the F₁ generation. In the F₂ generation the recessive traits is also expressed along with the dominant traits.</p>			1	
				1	
				1	3

Q15.	Acquired traits	Inherited traits		
	Do not bring changes in the DNA of germ cells.	Bring changes in the DNA of germ cells.	1	
1.	Cannot direct evolution	Can direct evolution	1	
2.	Cannot be passed on to the progeny	Can be passed on to the progeny	1	3
3.				

Q16. a)

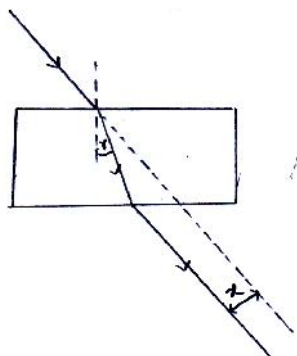

Diagram 1
Marking $\angle r$ and x $\frac{1}{2}, \frac{1}{2}$

b)

$${}_a n_g = \frac{3}{2}$$

$$\therefore {}_g n_a = \frac{1}{{}_a n_g} = \frac{1}{\frac{3}{2}} = \frac{2}{3}$$

Alternately,

$$\frac{c_{air}}{c_{glass}} = \frac{3}{2} \quad \therefore \frac{c_{glass}}{c_{air}} = \frac{2}{3}$$

1 3

Q17. Cause of dispersion of white light – Different colours of light bend through different angles with respect to the incident ray as they pass through a prism. Violet light bends the most and red the least. Thus, the each colour emerges along different paths.

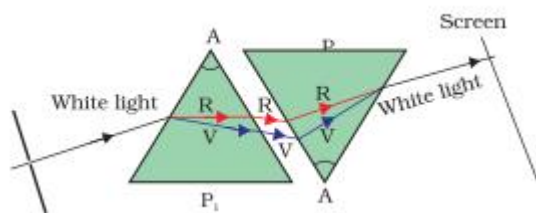

2 3

- Q18. a) The existence of decomposers is essential in a biosphere because they breakdown complex organic substances into simple inorganic substances that can be absorbed by the plants. Thus, decomposers
- replenish the soil naturally 1/2
 - helps in removing the biodegradable waste. 1/2
- b) In a food chain the energy moves progressively through the various trophic levels, it is no longer available to the previous level (autotrophs) and the energy captured by the autotrophs does not go back to the solar input. Hence, the flow of energy is unidirectional 1 1/2

3

- Q19. a) i) Pole – Centre of the reflecting surface of the mirror.
 ii) Centre of curvature – The centre of the hollow sphere of which the reflecting surface of mirror forms a part.
 iii) Principal axis – Straight-line passing through the pole and the centre of curvature of a spherical mirror.
 iv) Principal focus – Incident rays parallel to principal axis, after reflection, either converge to or appear to diverge from a fixed point on the principal axis called principal focus of the spherical mirror. 4x 1/2

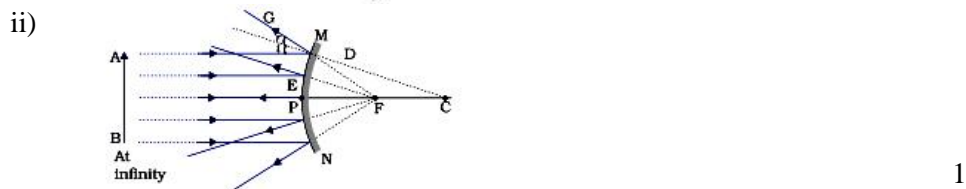
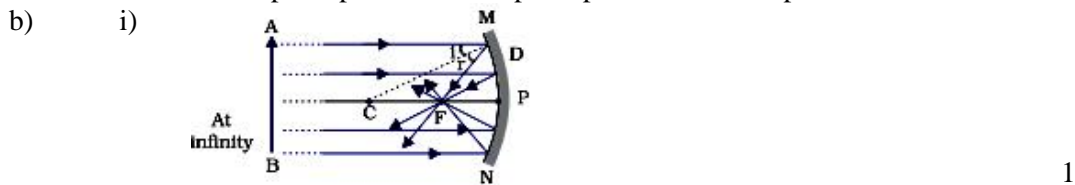

- c) Concave mirror 1/2
 Image formed is virtual 1/2 5

- Q20. a)
 - Cornea – Refracts the rays of light falling on the eye 1/2
 - Iris – Controls the size of the pupil 1/2
 - Crystalline lens – Focuses the image of the object on the retina 1/2
 - Ciliary muscles – Holds the eye lens and adjusts its focal length 1/2
 b) i) Objectives – To make people aware and realize their duties towards society. 1
 ii) One person can give sight to two people 1/2
 Our eyes can live even after our death 1/2
 iii) Concern for others/ Responsible behavior/ Group work/ or any other 2x 1/2 5
 (Any two)

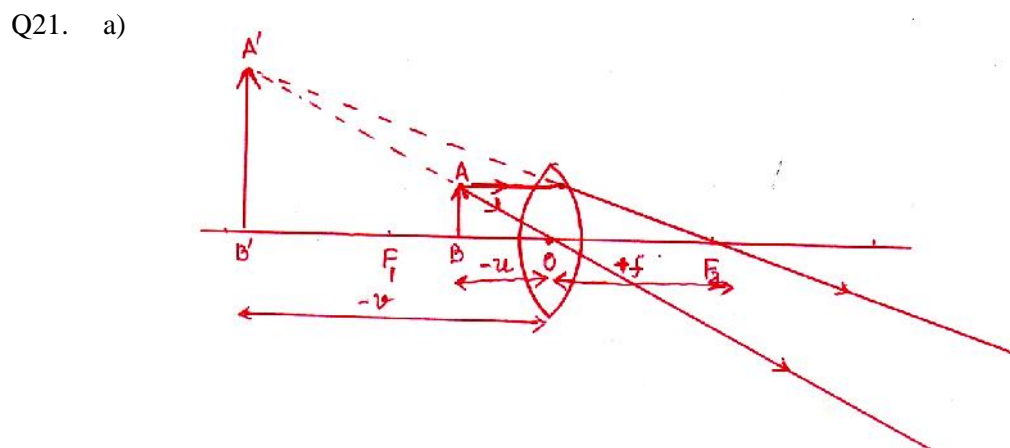

- b) Diagram 1
Marking of u & v 1/2, 1/2

Relation : $\frac{1}{f} = \frac{1}{v} - \frac{1}{u}$ 1/2

c)	$m = -1; u = -20\text{cm}; v = ? \quad f = ?$			
	$m = \frac{v}{u} \therefore v = +20\text{cm}$		1/2	
	Thus object is at 2F			
	i.e. $2f = 20\text{cm}$			
	$\therefore f = 10\text{cm} = 0.1\text{m}$		1	
	$P = \frac{1}{f} = \frac{1}{0.1} = +10\text{D}$		1	5
Q22.	a) (i) Ovary - (i) Production of female hormone		1/2	
	(ii) Production of female gamete		1/2	
	(ii) Oviduct - (i) Transfer of female gamete from the ovary		1/2	
	(ii) Site of fertilization		1/2	
	(iii) Uterus - (i) Implantation of the zygote		1/2	
	(ii) Nourishment of the developing embryo/ placenta formation		1/2	
	b) <u>Structure of Placenta</u> – it is a disc like structure embedded in the uterine wall connected to the embryo. It has villi on the embryo’s side of the tissue and on the mother side, it has blood spaces, which surround the villi.		1/2	
	<u>Function of Placenta</u> – it provides a large surface area for nutrients/ glucose and oxygen to pass from the mother’s side to the embryo and waste substances from the embryo’s side to mother’s blood.		1/2	5
Q23.	• <u>Speciation</u> :- The process of formation of a new species from a pre-existing one.		1	
	• <u>Four factors</u> :			
	Genetic drift			
	Mutation / Drastic change in the genes or DNA			
	Natural selection			
	Geographical isolation		4 x 1/2	
	• Geographical isolation cannot be a major factor in the speciation of a self-pollinating plant species.		1	
	• <u>Reason</u> :- Physical barrier cannot be created in self-pollinating plants.		1	5
Q24.	Pass the vapours of the given samples of saturated and unsaturated hydrocarbons into bromine water taken in two separate test tubes. The one which discharges the colour of bromine water is that of unsaturated hydrocarbon and the other represents saturated hydrocarbon. (or any other test)		2	
	On burning ethane in air, the products obtained are carbon dioxide and water, along with heat and light.		1	
	$2\text{C}_2\text{H}_6(\text{g}) + 7\text{O}_2(\text{g}) \rightarrow 4\text{CO}_2(\text{g}) + 6\text{H}_2\text{O}(\text{l}) + \text{Heat} + \text{Light}$		1	
	It is considered a substitution reaction because the hydrogen atoms of methane (CH_4) are replaced by chlorine atoms one by one.		1	5

SECTION – B

25 (c)	26 (d)	27 (a)		
28 (c)	29 (b)	30 (a)		
31 (c)	32 (a)	33 (d)	9 x 1	9

Q34.

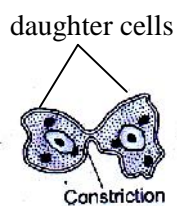

Diagram	1	
Labelling	½, ½	2

Q35. (i) Lens towards the screen/ screen away from the lens
(Note: one mark to be awarded for any other answer)

(ii) Increase

(iii) No image on the screen

1	
½	
½	2

Q36. (i) No change / or remains colourless

(ii) No change

(iii) Turns pink/orange

(iv) Evolution of a colourless/ odorless gas with brisk effervescence

4 x ½	2
-------	---