

MATHEMATICS

Class (IX)

TEAM MEMBERS

1.	Sh. S.B. Tripathi	V.PL., CRGSKV No. 2, Ghonda, Delhi (Group Leader)
2.	Mrs. Ritu Tiwari	TGT Maths RPVV, Surajmal Vihar, Delhi
3.	Mr. Neeraj Gupta	TGT Maths GBSSS, G.T. Road, Shahdara, Delhi
4.	Mr. S.A. Hasan	TGT Maths RPVV, Gandhi Nagar, Delhi
5.	Mr. Digvijai Singh	TGT Maths RPVV, Gandhi Nagar, Delhi
6.	Mr. J.S. Negi	TGT Maths GBSSS, J&K Block, Dilshad Garden, Delhi
7.	Mrs. Kavita Yadav	TGT Maths CRGSKV No. 2, Ghonda, Delhi
8.	Mrs. Bhawna Rohella	TGT Maths GGSSS, New Usmanpur, Delhi
9.	Mr. B.P. Singh	TGT Maths GBSS, GH Block, Old Seema Puri, Delhi
10.	Mr. Sanjay Aggarwal	TGT Maths RPVV, Shalimar Bagh, Delhi
11.	Mr. S.C. Aggarwal	TGT Maths GBSS, GH Block, Old Seema Puri, Delhi

SA-I

CHAPTERS

1. Number Systems
2. Polynomials.
3. Coordinate Geometry
4. Introduction to Euclid's Geometry
5. Lines and Angles
6. Triangles
7. Heron's Formula

COURSE STRUCTURE CLASS IX

First Term

Marks : 90

Units	Marks
I Number Systems	17
II Algebra	25
III Geometry	37
IV Coordinate Geometry	
V Mensuration	11
Total (Theory)	90

UNIT I : NUMBER SYSTEMS

1. Real Numbers (18 Periods)

1. Review of representation of natural numbers, integers, rational numbers on the number line. Representation of terminating / non-terminating recurring decimals on the numbers line through successive magnification. Rational numbers as recurring / terminating decimals.
2. Examples of non-recurring / non-terminating decimals. Existence of non-rational numbers (irrational numbers) such as $\sqrt{2}$, $\sqrt{3}$ and their representation on the number line. Explaining that every real number is represented by a unique point on the number line and conversely, viz. every point on the number line represents a unique real number.
3. Existence of \sqrt{x} for a given positive real number x and its representation on the number line with geometric proof.
4. Definition of n th root of a real number.

5. Recall of laws of exponents with integral powers. Rational exponents with positive real bases (to be done by particular cases, allowing learner to arrive at the general laws.)
6. Rationalization (with precise meaning) of real number of the type $\frac{1}{a + b\sqrt{x}}$ and $\frac{1}{\sqrt{x} + \sqrt{y}}$ (and their combinations) where x and y are natural number and a and b are integers.

Unit II : Algebra

1. Polynomials

Definition of a polynomial in one variable, with example and counter examples. Coefficients of a polynomial, terms of a polynomial and zero polynomial. Degree of a polynomial. Constant, linear, quadratic and cubic polynomial. Monomials, binomials, trinomials. Factors & multiples. Zeros of a polynomial. Motivate and State and Remainder Theorem with examples. Statement and proof of the Factor Theorem. Factorization of $ax^2 + bx + c$, $a \neq 0$ where a, b, and c are real numbers, and of cubic polynomials using the Factor Theorem.

Recall of algebraic expressions and identities. Verification of identities : $(x + y + z)^2 = x^2 + y^2 + z^2 + 2xy + 2yz + 2xz$, $(x \pm y)^3 = x^3 \pm y^3 \pm 3xy(x \pm y)$, $x^3 \pm y^3 = (x \pm y)(x^2 \mp xy + y^2)$, $x^3 + y^3 + z^3 - 3xyz = (x + y + z)(x^2 + y^2 + z^2 - xy - yz - zx)$ and their use in factorization of polynomials.

Unit III : Geometry

1. Introduction of Euclid's Geometry

History : Geometry in India and Euclid's geometry. Euclid's method of formalizing observed phenomenon into rigorous Mathematics with definitions, common/obvious notions, axioms / postulates and theorems. The five postulates of Euclid. Equivalent versions of the fifth postulate. Showing the relationship between axiom and theorem, for example :

(Axiom) 1. Given two distinct points, there exists one and only one line through them.

(Theorem) 2. (Prove) Two distinct lines cannot have more than one point in common.

2. Lines and Angles

(13 Periods)

1. (Motivate) If a ray stands on a line, then the sum of the two adjacent angles so formed is 180° and the converse.

2. (Prove) If two lines intersect, vertically opposite angles are equal.
3. (Motivate) Results on corresponding angles, alternate angles, interior angles when a transversal intersects two parallel lines.
4. (Motivate) Lines which are parallel to a given lines a parallel.
5. (Prove) The sum of the angles of a triangle is 180° .
6. (Motivate) If a side of a triangle is produced, the exterior angle so formed is equal to the sum of the two interior opposite angles.

3. Triangles (20 Periods)

1. (Motivate) Two triangles are congruent if any two sides and the included angles of one triangle is equal to any two sides and the included angles of the other triangle (SAS Congruence).
2. (Prove) Two triangles are congruent if any two angles and the included side of the one triangle is equal to any two angles and the included side of the other triangle (ASA Congruence).
3. (Motivate) Two triangles are congruent if the three sides of one triangle are equal to three sides of the other triangle (SSS Congruence).
4. (Motivate) Two right triangles are congruent if the hypotenuse and a side of one triangle are equal (respectively) to the hypotenuse and a side of the other triangle. (RHS Congruence).
5. (Prove) The angles opposite to equal sides of a triangle are equal.
6. (Motivate) The sides opposite to equal angles of a triangle are equal.
7. (Motivate) Triangle inequalities and relation between 'angle and facing side' inequalities in triangles.

Unit IV : Coordinate Geometry

Coordinate Geometry (6 Periods)

The Cartesian plane, coordinates of a point, names and terms associated with the coordinate plane, notions, plotting points in the plane.

Unit V : Mensuration

1. Areas (4 Periods)

Area of a triangle using Heron's formula (without proof) and its application in finding the area of a quadrilateral.

QUESTION PAPER DESIGN 2016-17

CLASS-IX

Mathematics (Code No. 041)		Time : 3 Hours				Marks : 90	
S.No.	Typology of Questions	Very Short Answer (VSA) (1 Mark)	Short Answer I (SA) (2 Marks)	Short Answer II (SA) (3 Marks)	Long Answer (LA) (4 Marks)	Total Marks	% Weightage
1.	Remembering (Knowledge Based Simple recall questions, to know specific facts, terms, concepts, principles, or theories; identify, define, or recite, information)	1	2	2	3	23	26%
2.	Understanding (Comprehension -to be familiar with meaning and to understand conceptually, interpret, compare, contrast, explain, paraphrase, or interpret information)	2	1	1	4	23	26%
3.	Application (Use abstract information in concrete situation, to apply knowledge to new situations; Use given content to interpret a situation provide an example, or solve a problem)	1	2	3	2	22	24%
4.	Higher Order Thinking Skills (Analysis & Synthesis - Classify compare, contrast, or differentiate between pieces of information; Organize and/or integrate variety of sources)	-	1	4	-	14	16%
5.	Creating : Evaluation and Multi-Disciplinary- (Generating new ideas , product of ways of viewing things Appraise, judge and/or justify the values or worth of a decision or outcome, or to predict outcomes based on values).	-	-	-	2*	8	8%
Total		4 × 1 = 4	6 × 2 = 11	10 × 3 = 30	11 × 4 = 44	90	100%

Note : The question paper will included a section on Open Text based assessment (questions of 10 marks). The case studies will be supplied to students in advance. These case studies of designed to test the analytical and higher order thinking skills of students.

*One of the LA (4 Marks) will be to assess the values inherent in the text.

CHAPTER 1

NUMBER SYSTEMS

- Every Irrational number can be represented on a number line using Pythagoras theorem.
- Rationalisation means to change the Irrational denominator to rational form.
- To rationalise the denominator of $\frac{1}{\sqrt{a+b}}$, We multiply this by $\frac{\sqrt{a-b}}{\sqrt{a-b}}$, where a and b are integers.
- Laws of Exponents : Let $a > 0$ be a real number and m and n are rational numbers, then

1. $a^m \cdot a^n = a^{m+n}$

2. $a^m \div a^n = a^{m-n}$

3. $(a^m)^n = a^{mn}$

4. $a^m \cdot b^m = (ab)^m$

5. $a^0 = 1$

6. $a^{-m} = \frac{1}{a^m}$

- For positive real number a and b, the following Identities hold

1. $\sqrt{a} \cdot \sqrt{b} = \sqrt{ab}$

2. $\sqrt{a} \div \sqrt{b} = \sqrt{\frac{a}{b}}$

3. $(\sqrt{a} + \sqrt{b})(\sqrt{a} - \sqrt{b}) = a - b$

4. $(\sqrt{a} + \sqrt{b})^2 = a + 2\sqrt{ab} + b$

5. $(a + \sqrt{b})(a - \sqrt{b}) = a^2 - b$

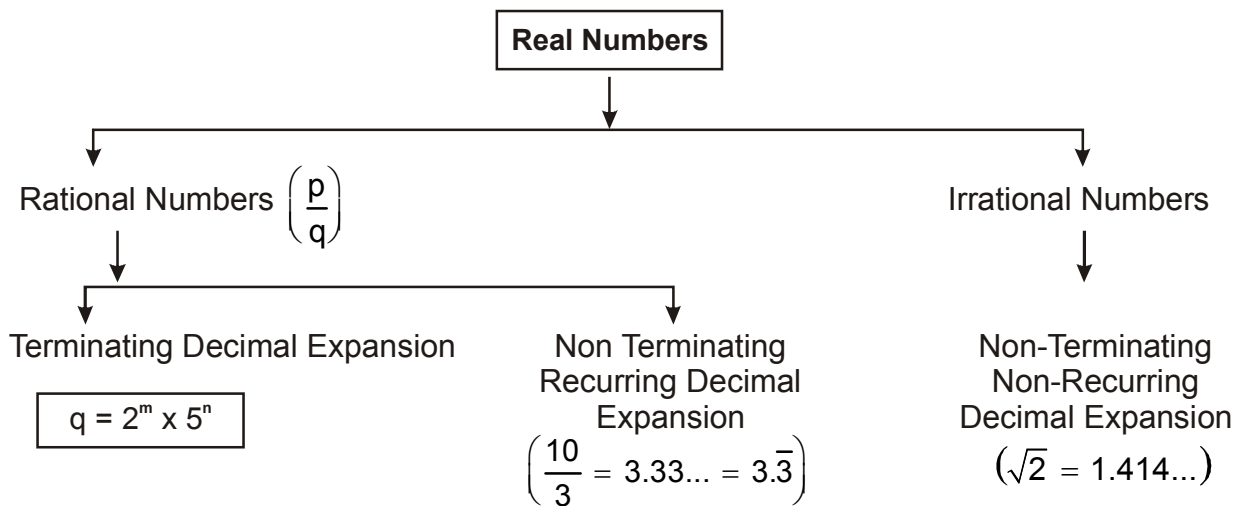

- Types of Numbers :

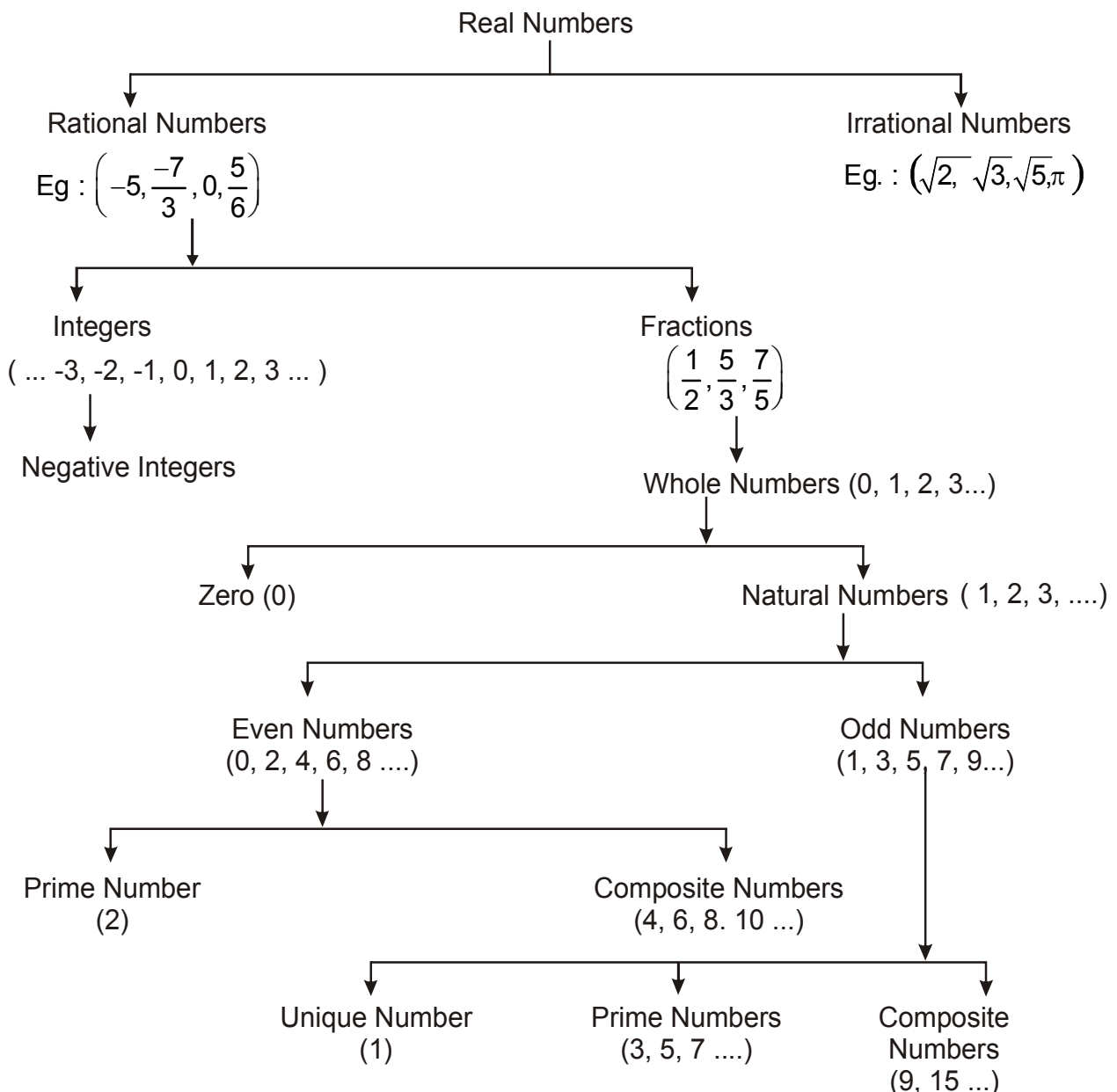

- Sequence of various types of Numbers :

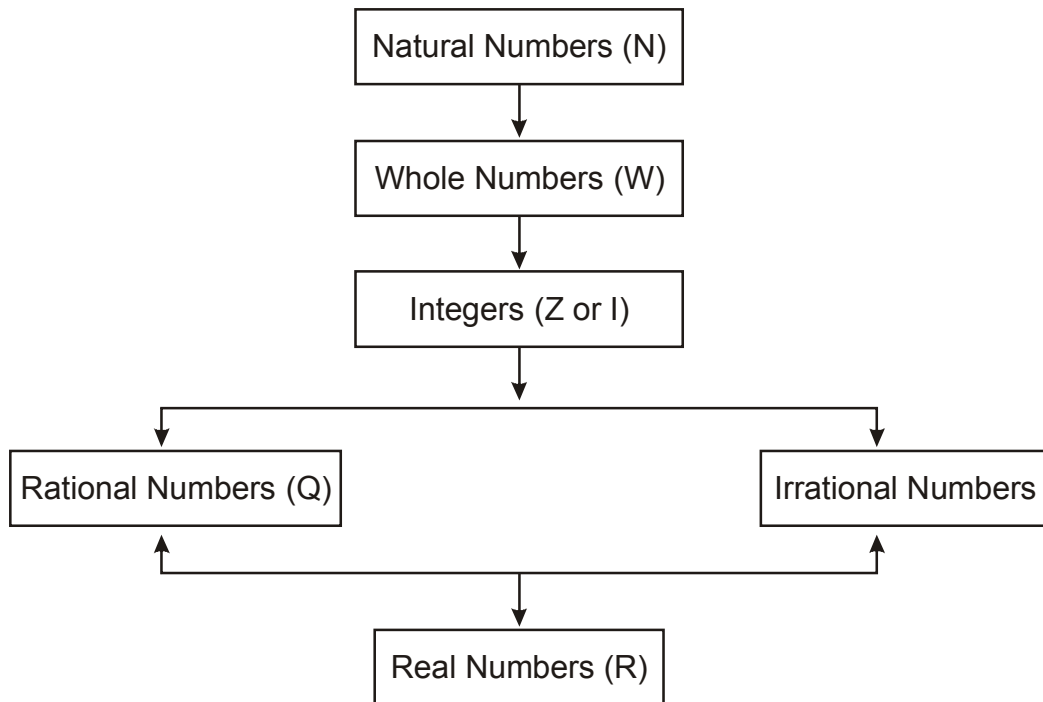

NUMBER SYSTEMS

PART (A)

1. Write first five whole numbers in $\frac{p}{q}$ form. where p and q are integers and $q \neq 0$
2. Find decimal expansion of $\frac{17}{8}, \frac{3}{15}, \frac{2}{7}, \frac{50}{3}$.
3. Find four rational numbers between $\frac{2}{9}$ and $\frac{3}{7}$.
4. Find decimal form of $\sqrt{23}$ and $\sqrt{24}$ upto 3 decimal places.
5. Find two Irrational numbers between $\sqrt{23}$ and $\sqrt{24}$.
6. Find one Irrational and one rational number between 2 and $\sqrt{5}$.
7. Write two numbers whose decimal expansions are terminating.
8. What can be the maximum number of digits in the repeating block of digits in the decimal expansion of $\frac{5}{7}$?
9. Write two numbers whose decimal expansions are non-terminating non-repeating (non-recurring).
10. Find the value of $(256)^{0.16} \times (256)^{0.09}$
11. Find two Irrational numbers between 2016 and 2017.

PART (B)

12. Representation $\frac{-7}{5}$ on the number line.
13. Represent $\sqrt{5}$ on the number line.
14. Represent $3 + \sqrt{2.6}$ on the number line.
15. Insert two Irrational numbers between $\frac{2}{3}$ and $\frac{3}{2}$.

16. Simplify : $\frac{\sqrt{5} + \sqrt{3}}{\sqrt{80} + \sqrt{48} - \sqrt{45} - \sqrt{27}}$
17. Find the value of $[1^3 + 2^3 + 3^3 + 8^2]^{-5/2}$
18. Find the value of x if $x^{1/2} = (36)^{0.5}$
19. Find the value of x if $(\sqrt{3})^x = 3^7$
20. If $2^{5x} \div 2^x = \sqrt[5]{32}$. Then find the value of x.
21. Evaluate $a^{x-y} \cdot a^{y-z} \cdot a^{z-x}$.
22. Simplify $12^{\frac{2}{5}} \cdot 5^{\frac{2}{5}}$.
23. Which of the following rational numbers will have a terminating decimal expansion or a non-terminating repeating (recurring) decimal expansion ?
- (i) $\frac{135}{50}$ (ii) $\frac{4}{11}$ (iii) $\frac{8}{7}$ (iv) $6\frac{3}{8}$
- (v) $\frac{55}{9}$ (vi) $\frac{5^2 \times 3^3}{2 \times 5^3 \times 27}$ (vii) $\frac{51}{60}$.
24. Classify the following numbers as terminating decimal or non-terminating recurring decimal or non-terminating non-recurring decimal :
- (i) 0.1666.... (ii) 0.250 (iii) 1.01001000100001....
- (iv) 0.27696 (v) 2.142857142857.... (vi) $0.\bar{3}$
- (vii) 0.2359872785.... (viii) 0.48484884848.... (ix) 2.502500250002....
- (x) $4.\overline{123456789}$
- Classify these given numbers also as Rational or Irrational numbers.
25. Classify the following numbers as rational or Irrational number :
- (i) $\sqrt{27}$ (ii) $\sqrt{36}$ (iii) $\sqrt{5} \times \sqrt{125}$ (iv) $2\sqrt{3}$
- (v) $\frac{7\sqrt{7}}{\sqrt{343}}$ (vi) $2 + \sqrt{21}$ (vii) $5 + 2\sqrt{3} - (\sqrt{25} + \sqrt{92})$
- (viii) $\frac{22}{7}$ (ix) π (x) $\sqrt[3]{27}$

26. Express the following numbers in the form $\frac{p}{q}$, where p and q are integers and $q \neq 0$.

(i) 0.0875 (ii) 2.123456789 (iii) 0.181818....

(iv) $0.4\overline{37}$ (v) $3.6\overline{51}$ (vi) $0.\overset{\circ}{4}2857\overset{\circ}{1}$

27. Do as directed :

(i) Add : $\sqrt{125} + 2\sqrt{27}$ and $-5\sqrt{5} - \sqrt{3}$

(ii) Add : $\sqrt{7} - \sqrt{11}$ and $\sqrt{5} - \sqrt{11} + \sqrt{13}$

(iii) Multiply : $2\sqrt{2}$ by $5\sqrt{2}$.

(iv) Multiply : $(-3 + \sqrt{5})$ by 3.

(v) Divide : $7\sqrt{5}$ by $-14\sqrt{125}$

(vi) Divide : $2\sqrt{216} - 3\sqrt{27}$ by 3.

28. Simplify :

(i) $(2\sqrt{2} + 3\sqrt{3})(2\sqrt{2} - 3\sqrt{3})$ (ii) $(2\sqrt{8} - 3\sqrt{2})^2$

(iii) $(\sqrt{7} + \sqrt{6})^2$ (iv) $(6 - \sqrt{2})(2 + \sqrt{3})$

29. Evaluate :

(i) $\frac{2^{38} + 2^{37} + 2^{36}}{2^{39} + 2^{38} + 2^{37}}$ (ii) $\left[\left(64^{\frac{1}{2}} \right)^{\frac{1}{6}} \right]^2$

30. Find the value of a if $\frac{6}{3\sqrt{2} - 2\sqrt{3}} = 3\sqrt{2} - a\sqrt{3}$.

31. Simplify : $\left[5(8^{1/3} + 27^{1/3})^3 \right]^{\frac{1}{4}}$

32. Simplify : $\frac{(25)^{3/2} \times (243)^{3/5}}{(16)^{5/4} \times (8)^{4/3}}$

33. If $5^{2x-1} - (25)^{x-1} = 2500$, then find the value of x.

PART D

34. Express $0.6 + 0.\overline{7} + 0.4\overline{7}$ in the form $\frac{p}{q}$ where p and q are integers and $q \neq 0$.

35. Rationalise the denominator of $\frac{1}{\sqrt{3} + \sqrt{5} + \sqrt{7}}$

36. Find a and b if $\frac{7 + 3\sqrt{5}}{2 + \sqrt{5}} - \frac{7 - 3\sqrt{5}}{2 - \sqrt{5}} = a + b\sqrt{5}$

37. If $x = (3 - 2\sqrt{2})$, show that $\left(\sqrt{x} - \frac{1}{\sqrt{x}}\right) = \pm 2$

38. If $xyz = 1$, then simplify

$$(1 + x + y^{-1}) \times (1 + y + z^{-1})^{-1} \times (1 + z + x^{-1})^{-1}$$

39. Find the value of x if

(i) $25^{2x-3} = 5^{2x+3}$

(ii) $(4)^{2x-1} - (16)^{x-1} = 384$

40. Evaluate : $\frac{64^{\frac{a}{6}}}{4^a} \times \frac{2^{2a+1}}{2^{a-1}}$.

41. Simplify : $\frac{1}{1 + x^{b-a} + x^{c-a}} + \frac{1}{1 + x^{a-b} + x^{c-b}} + \frac{1}{1 + x^{a-c} + x^{b-c}}$

42. Simplify : $\left(\frac{x^a}{x^{-b}}\right)^{a-b} \times \left(\frac{x^b}{x^{-c}}\right)^{b-c} \times \left(\frac{x^c}{x^{-a}}\right)^{c-a}$

43. Show that : $\frac{1}{(3 - \sqrt{8})} - \frac{1}{(\sqrt{8} - \sqrt{7})} + \frac{1}{(\sqrt{7} - \sqrt{6})} - \frac{1}{(\sqrt{6} - \sqrt{5})} + \frac{1}{(\sqrt{5} - 2)} = 5$

44. If $a = \frac{\sqrt{7} - \sqrt{6}}{\sqrt{7} + \sqrt{6}}$ and $b = \frac{\sqrt{7} + \sqrt{6}}{\sqrt{7} - \sqrt{6}}$, then find the value of $a^2 + b^2 + ab$.

45. Simplify : $\frac{2\sqrt{6}}{\sqrt{2} + \sqrt{3}} + \frac{6\sqrt{2}}{\sqrt{6} + \sqrt{3}} - \frac{8\sqrt{3}}{\sqrt{6} + \sqrt{2}}$

46. If $x = 9 - 4\sqrt{5}$, then find

(i) $x + \frac{1}{x}$

(ii) $x - \frac{1}{x}$

(iii) $x^2 + \frac{1}{x^2}$

(iv) $x^2 - \frac{1}{x^2}$

(v) $x^3 + \frac{1}{x^3}$

(vi) $x^3 - \frac{1}{x^3}$

(vii) $\sqrt{x} + \frac{1}{\sqrt{x}}$

(viii) $\sqrt{x} - \frac{1}{\sqrt{x}}$

(ix) $x^4 + \frac{1}{x^4}$

(x) $x^6 + \frac{1}{x^6}$

(xi) $x + \frac{14}{x}$

ANSWER

PART A

1. $\frac{0}{1}, \frac{1}{1}, \frac{2}{1}, \frac{3}{1}, \frac{4}{1}$
2. $\frac{17}{8} = 2.125, \frac{3}{15} = 0.2, \frac{2}{7} = 0.\overline{285714}, \frac{50}{3} = 16.\overline{6}$
3. $\frac{15}{63}, \frac{16}{63}, \frac{17}{63}, \frac{18}{63}$ (other answers are possible).
4. $\sqrt{23} = 4.795, \sqrt{24} = 4.898$
5. 4.8010010001, 4.8020020002, (other answers are possible)
6. 2.1, 2.010010001, (other answers are possible).
8. 6
10. 4
11. 2016.1010010001 ; 2016.2020020002; (other answers are possible)

PART B

15. 0.909009000; 1.10100100010000 (other answers are possible)
16. 1
17. $\frac{1}{10^5}$
18. 36
19. 14
20. $x = \frac{1}{4}$
21. 1
22. $(60)^{2/5}$
23. (i) Terminating Decimal (ii) Non Terminating Repeating Decimal.
(iii) Non-Terminating Repeating Decimal
(iv) Terminating Decimal (v) Non-Terminating Repeating Decimal

- (vi) Terminating Decimal (vii) Terminating Decimal
24. (i) Non-Terminating Repeating Decimal (Rational).
 (ii) Terminating Decimal (Rational).
 (iii) Non-Terminating Non-Repeating Decimal (Irrational).
 (iv) Terminating Decimal (Rational)
 (v) Non-Terminating Repeating Decimal (Rational)
 (vi) Non-Terminating Repeating Decimal (Rational)
 (vii) Non-Terminating Non-Repeating Decimal (Irrational)
 (viii) Non-Terminating Non-Repeating Decimal (Irrational)
 (ix) Non-Terminating Non-Repeating Decimal (Irrational)
 (x) Non-Terminating Repeating Decimal (Rational).
25. (i) Irrational (ii) Rational (iii) Rational (iv) Irrational
 (v) Rational (vi) Irrational (vii) Rational) (viii) Rational
 (ix) Irrational (x) Rational
26. (i) $0.0875 = \frac{7}{80}$ (ii) $\frac{2123456789}{1000000000}$ (iii) $\frac{2}{11}$ (iv) $\frac{433}{990}$
 (v) $\frac{1643}{450}$ (vi) $\frac{1643}{450}$
27. (i) $5\sqrt{3}$ (ii) $\sqrt{5} - 2\sqrt{11} + \sqrt{7} + \sqrt{13}$ or $(\sqrt{5} + \sqrt{7} - 2\sqrt{11} + \sqrt{13})$
 (iii) 20 (vi) $-9 + 3\sqrt{5}$ (v) $-\frac{1}{10}$ (vi) $4\sqrt{6} - 3\sqrt{3}$

PART C

28. (i) -19 (ii) 2 (iii) $13 + 2\sqrt{42}$
 (iv) $12 + 6\sqrt{3} - 2\sqrt{2} - \sqrt{6}$
29. (i) $\frac{1}{2}$ (ii) 2

30. $a = -2$ 31. 5 32. $\frac{3375}{512}$ 33. $x = 3$

PART D

34. $\frac{167}{90}$
35. $\frac{1}{59}(9\sqrt{3} + 5\sqrt{5} + \sqrt{7} - 2\sqrt{105})$
36. $a = 0, b = 2$
38. $\frac{1}{(1 + y + xy)(1 + z + yz)(1 + x + zx)}$
39. (i) $\frac{9}{2}$ (ii) $\frac{11}{4}$
40. 4 41. 1 42. 1
44. $a^2 + b^2 + ab = 675$
45. $8\sqrt{3} - 14\sqrt{2}$
46. (i) 18 (ii) $-8\sqrt{5}$ (iii) 322 (iv) $-144\sqrt{5}$
(v) 5778 (vi) $-2584\sqrt{5}$ (vii) $2\sqrt{5}$ (viii) 4
(ix) 103682 (x) 33385282 (xi) $8\sqrt{3} - 14\sqrt{2}$

CHAPTER 2

POLYNOMIALS**BASIC CONCEPTS**

- A Polynomials $p(x)$ in one variable x is an algebraic expression in x of the form $p(x) = a_n x^n + a_{n-1} x^{n-1} + \dots + a_1 x + a_0$, where $a_0, a_1, a_2, \dots, a_n$ are constant and $a_n \neq 0$ are called coefficients and n is a positive integer.
- The highest power of variable x in a pollynomial $p(x)$ is called the degree of the polynomial.
- A polynomial having one term is called monomial having two terms called binomial and having three terms called trinomial.
- A polynomial of degree zero is called constant polynomial
- A polynomial of degree one is called linear polynomial having degree 2 is called quadratic polynomial and of degree three is called cubic polynomial.
- For a polynomial $p(x)$ if $p(a) = 0$ where a is a real number we say that 'a' is a zero of the polynomial.
- If $p(x)$ is any polynomial of degree greater than or equal to 1 and $p(x)$ is divided by a linear polynomial $x - a$, then the remainder is $p(a)$. This is called remainder theorem.
- If $p(x)$ is a polynomial of degree ≥ 1 and 'a' is any real number then
 - (i) $(x - a)$ is a factor of $p(x)$, if $p(a) = 0$ and
 - (ii) $p(a) = 0$ if $(x - a)$ is a factor of $p(x)$.This is called factor theorem.
- A polynomial of degree 'n' can have at most n zeros.

CHAPTER 2

POLYNOMIALS

PART – A

1. Write the coefficient of y^3 in $5y^3 + 2y^2 - y + 5$
2. Find the coefficient of x^2 in $(x^2 - 1)(x - 2)$
3. If $(x - 2)$ is one of the factor of $3x - 2a$, then find the value of a .
4. Find the degree of polynomial $\frac{x^3 + 3x - 1}{5} - \frac{5}{2}x^2 - x^5$
5. If $p(x) = x^3 - 3x^2 + 2x - 3$ find the value of $p(1) + p(-1)$
6. Find zeros of the polynomial $z^2 - 8$
7. Divident = Divisor \times Quotient + _____.
8. Give an example of Trinomial of degree 3.
9. Give one example of each monomial, binomial and quadratic polynomial.
10. Check whether $x = 3$ is zero of polynomial $x^2 - 3x + x - 3$.
11. Write the degree of the polynomial $\sqrt{7}$
12. If one of the zero of polynomial $3x^2 + 5x + k$ is -1 , then find out the value of k .
13. Express $4x^2 - 4x + 1$ as a square of binomial.

PART – B

14. Check whether $q(x)$ is a multiple of $r(x)$ or not.
If $q(x) = 2x^3 - 11x^2 - 4x + 5$, $r(x) = 2x + 1$
15. Show that $(x - 5)$ is a factor of $x^3 - 3x^2 - 4x - 30$ by Remainder theorem.
16. Evaluate by using suitable identify : $(997)^3$
17. Find the zeros of the polynomial $p(x) = x(x - 2)(x + 3)$
18. Find the quotient when $3x^2 - 7x - 6$ is divided by $(x - 3)$
19. Factorise $8x^3 + \sqrt{27}y^3$.

20. If $p(x) = x + 9$, then find $p(x) + p(-x)$
21. Find the product without multiplying directly
 106×94
22. If $36x^2 - b = \left(6x + \frac{1}{5}\right)\left(6x - \frac{1}{5}\right)$ then find the value of b .
23. Expand using suitable identity $(2x - 3y + z)^2$
24. Find the value of $(351)^2 - (350)^2$.

PART - C

25. Factorise $64a^2 + 96ab + 36b^2$
26. Factorise $x^3 + 6x^2 + 11x + 6$
27. If $x^2 + y^2 = 49$ and $x - y = 3$, then find the value of $x^3 - y^3$
28. Simplify $(5a - 2b)(25a^2 + 10ab + 4b^2) - (2a + 5b)(4a^2 - 10ab + 25b^2)$
29. Find the sum of remainders when $x^3 - 3x^2 + 4x - 4$ is divided by $(x - 1)$ and $(x + 2)$.
30. Find the product $\left(p - \frac{1}{p}\right)\left(p + \frac{1}{p}\right)\left(p^2 + \frac{1}{p^2}\right)\left(p^4 + \frac{1}{p^4}\right)$.
31. Factorise $7\sqrt{2}k^2 - 10k - 4\sqrt{2}$
32. Simplify $(3x - 4y)^3 - (3x + 4y)^3$
33. Expand $\left(\frac{1}{2}x - \frac{1}{4}y + 2\right)^2$ using suitable identity
34. Simplify $(x + y + z)^2 - (x - y - z)^2$.

PART - D

35. Factorise : $125x^3 + 8y^3 + Z^3 - 30xyz$.
36. $x + 2$ is a factor of polynomial $ax^3 + bx^2 + x - 2$ and the remainder 4 is obtained by dividing this polynomial by $(x - 2)$. Find the value of a and b .
37. Check whether
 $p(t) = 6t^3 + 3t^2 + 3t + 18$ is a multiple of $(2t + 3)$.

38. Find the value of k if $(x + k)$ is a factor of the polynomial $x^3 + kx^2 - 2x + k + 4$ and factorise $x^4 - x$.
39. If $(x - 3)$ and $\left(x - \frac{1}{3}\right)$ are factors of the polynomial $px^2 + 3x + r$, show that $p = r$.
40. Find
- (i) $(-7)^3 + (5)^3 + (2)^3$ using identity
 - (ii) Find dimension of cube whose volume is given by expression $4x^2 + 14x + 6$
41. Give possible expression for the length and breadth of each of the following rectangles if.
- (i) Area $(x^2 + 5\sqrt{5}x + 30)$ sq. unit.
 - (ii) Area = $(24x^2 - 26x - 8)$ sq. unit.
42. A literacy campaign was organised by Class IX students under NSS. Students made $(x - 5)$ rows and $(3x - 4)$ columns, for the rally.
- (a) Write the total number of students in the form of polynomial.
 - (b) Which values of students are depicted here?
43. A principal of school wants to distribute some material of volume $(x^3 + 9x^2 + 27x + 27)$ cubic unit. Each topper will receive quantity of material equal to dimensions of the material. State whether
- (i) It is possible to find the quantity of material distributed to each topper.
 - (ii) Which moral values are depicted.
44. Under tree plantation programme students of Class VIII and IX planted $(3x^2 - 4x - 4)$ trees in school.
- (a) If number of students in those classes are $(x - 2)$ then find out number of trees planted by them.
 - (b) What values of students are exhibited here?

ANSWER

PART A

1. 5
2. -2
3. $a = 3$
4. 5
5. -12
6. $+\sqrt{8}, -\sqrt{8}$
7. Remainder
8. $x^3 - 3x^2 + 2$ or any other example
9. $2x, 2x^2 + 3, x^2 + 2x - 3$ or any other examples
10. Yes
11. Degree = 0
12. $k = 2$
13. $(2x - 1)^2$
14. No
15. Hint put $x = 5$
16. 991026973
17. 0, 2, -3
18. $3x + 2$
19. $(2x + \sqrt{3}y)(4x^2 - 2\sqrt{3}xy + 3y^2)$
20. 18
21. Hint $(100 + 6(100 - 6))$
22. $\frac{1}{25}$
23. $4x^2 + 9y^2 + z^2 - 12xy - 6yz + 4xz$
24. 701
25. $(8a + 6b)^2$
26. $(x + 1)(X + 2)(x + 3)$
27. 207
28. $117a^3 - 133b^3$
29. -34
30. $p^8 - \frac{1}{p^8}$
31. $(k - \sqrt{2})(7\sqrt{2}k + 4)$
32. $-8y(16y^2 + 27x^2)$ or $-128y^3 - 216x^2y$
33. $\frac{x^2}{4} + \frac{y^2}{16} + 4 - \frac{1}{4}xy - y + 2x$
34. $4xy + 4zx$
35. $(5x + 2y + z)(25x^2 + 4y^2 + z^2 - 10xy - 2yz - 5zx)$
36. $a = 0, b = 2$
37. Check
38. $k = \frac{4}{3}, x(x - 1)(x^2 + x + 1)$
40. (i) -210; (ii) 2, $(x + 3), (2x + 1)$

41. (i) $(x + 2\sqrt{5}), (x + 3\sqrt{5})$; (ii) $(4x + 1), (6x - 8)$
42. (a) $(x - 5)(3x - 4)$; (b) Social responsibility, Empathy concerned.
43. Equal amount $(x + 3)$ Unit, Motivation without discrimination.
44. (a) $(3x + 2)$; (b) Scientific attitude, Dutiful, Environment awareness, Social values

CHAPTER 3

CO-ORDINATE GEOMETRY**BASIC CONCEPTS**

- **Cartesian System** : To locate the position of a point in plane is called the cartesian system.
- **Coordinate Axes** : The position of a point in a plane is determined with reference to two fixed mutually perpendicular lines, called coordinate axes.

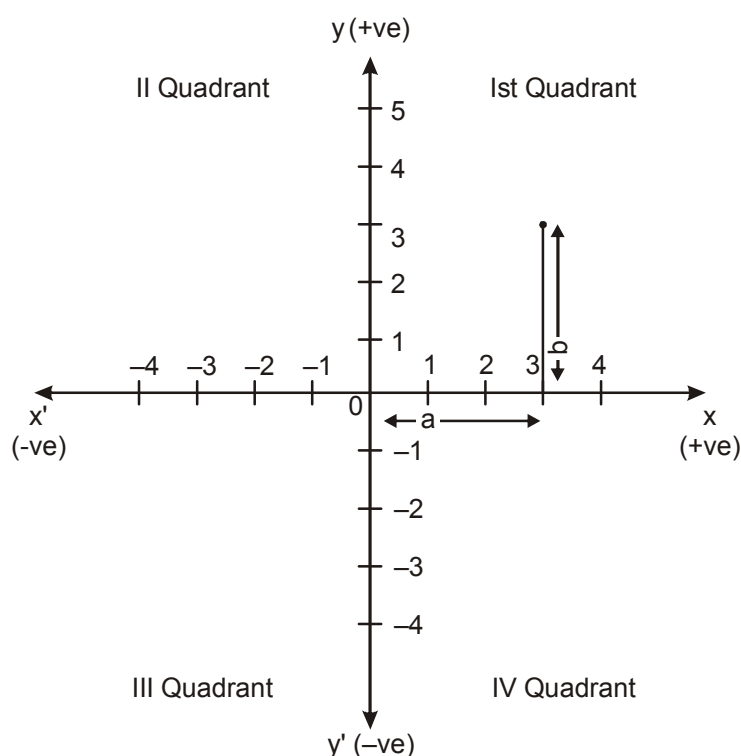

This horizontal line xox' is called x-axis.

The vertical line yoy' is called y-axis.

The intersection point of these two lines is called origin.

- **Ordered Pair** : Location of a point in cartesian system, the point is written in the form of ordered pair say $P(a, b)$
 a is the point of x-axis known as abscissa of P .
 b is the point of y-axis known as ordinate of P .

- Location of a point P (a, b) on graph with sign convention –
where a and b are such that —

	Value of point	sign of point	Location of point
(i)	$a = 0, b = 0$	—	origin
(ii)	$a > 0, b > 0$	(+, +)	Ist Quadrant
(iii)	$a < 0, b > 0$	(-, +)	IInd Quadrant
(iv)	$a < 0, b < 0$	(-, -)	IIIrd Quadrant
(v)	$a > 0, b < 0$	(+, -)	IVth Quadrant

Note : If a point lies on x-axis or y-axis it does not lie in any quadrant.

CHAPTER 3

CO-ORDINATE GEOMETRY**PART – A**

1. In which quadrant do the given points lie.
(i) (3, -2) (ii) (17, -30), (iii) (-2, 5), (iv) (-50, -20)
(v) (10, 100) (vi) (-81, 80)
2. On which axes do the given points lie.
(i) (11, 0), (ii) (-11, 0), (iii) 0, 14) (iv) (0, -100)
3. The abscissa and ordinate of a point are -3 and -5 respectively then write down the ordered pair.
4. Write the name of the point where both axes intersect?
5. Is P(7, 0) and Q (0, 7) represent the same point?
6. In which quadrant x coordinate is negative?
7. Name the figure formed when we plot the points (0, 0), (4, 4) and (0, 4) on a graph paper.
8. In which quadrant, does the point with values $x > 0$ and $y > 0$ exists.
9. In the cartesian plane the linear equation $x - 5 = 0$ is parallel to which axes?
10. Write the coordinates of the fourth vertex of a square when three of its vertices are given by (1, 2) (5, 2) (5, -2).
11. The perpendicular distance of the point P (5, 2) from x-axis is _____ and from y-axis is _____.
12. The perpendicular distance of the point Q (-116, -80) from x-axis is _____ and from y-axis is _____.

PART – B

13. Write the mirror image of the point S(-5, 7) by using x-axis is _____.
14. Find the distance of the point P(4, 0) from origin.

15. Draw the lines of coordinate axes on the plane of a graph paper and plot the given points

- (i) A (3, 5) (ii) B $(-7/2, 0)$, (iii) C (2, -6) (iv) D (-6, -4)
(v) E $(0, -5/2)$ (vi) F (8, 0)

16. Write the coordinates of each of points in the given figure.

A, B, C, P, Q, R

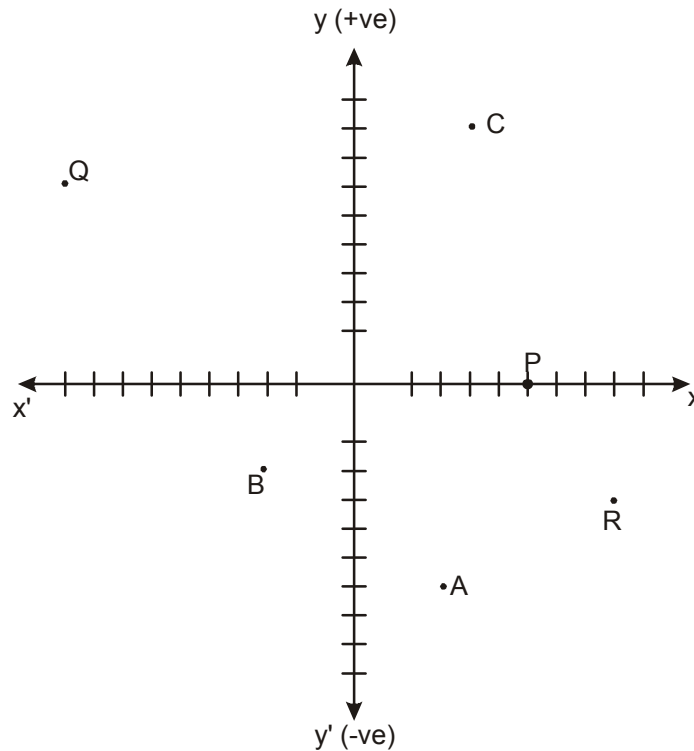

17. Point P(4, 3) is in the first quadrant. Find the coordinate of the point Q, opposite to P in fourth quadrant.
18. Find the distance of point P (8, 3) from x axis.
19. Write the name of the figure formed by joining the points A (-3, 0), B (0, 3) and C (3, 0) in the cartesian plane.
20. Write the coordinates of the point that lies on y-axis and is at a distance of 2 units in upward direction.

PART – C

21. Draw a line segment on a graph paper whose end points lies in first quadrant and third quadrant. Write the coordinates of its end points and mid point of line segment.
22. Plot point A(7, 6) and B (7, -6) on graph paper. Join the points and answer of the

following :

- (i) It is a line or not.
 - (ii) Write the coordinate of the point where it cuts the x-axis?
 - (iii) If it is a line, then which axis is parallel to this line?
23. Draw a triangle on graph paper having the coordinates of its vertices are A (-2, 0), B (4, 0) and C (1, 5). Also find the area of triangle.
24. If we plot the points P(5, 0), Q (5, 5), R(-5, 5) and S (-5, 0), which figure will we get? Name the symmetrical axis of this figure?
25. Find the coordinate of a point which is equidistant from the two points (-4, 0) and (4, 0). How many of such points are possible satisfying the condition?
26. Draw a quadrilateral with vertices A (4, 3), B(-4, 3), C(-4, -3) and D(4, -3). Draw its diagonals and write the coordinates of a point where they cuts on a graph paper?

PART – D

27. A rectangular field is of length 10 units & breadth 8 units. One of its vertex lie on the origin. The longer side is along x-axis and one of its vertices lie in first quadrant. Find all the vertices.
28. Plot the points B (5, 3), E(5, 1), S (0, 1) and T(0, 3) and answer the following :
- (i) Join the points and name the figure obtained.
 - (ii) Find the area of figure.
 - (iii) Which mathematical concept has been used in this problem.

ANSWERS

1. (i) IV Quadrant (ii) IV Quadrant (iii) II Quadrant (iv) III Quadrant
(v) I Quadrant (vi) II Quadrant
2. (i) x-axis (ii) x-axis (iii) y-axis (iv) y-axis
3. $(-3, -5)$ 4. Origin 5. Yes 6. II and III Quadrant
7. Right Angle Triangle 8. Ist Quadrant 9. y-axis
10. $(1, -2)$
11. x-axis — 2 units; y-axis — 5 units
12. x-axis — 80 units; y-axis — 116 units
13. $(-5, -7)$ 14. 4 units 17. $(4, -3)$ 18. 3 Units
19. Triangle or Isosceles Triangle 20. $(0, 2)$ 23. 15 square units
24. Rectangle, y-axis
25. Any point on y-axis, infinite
26. At origin $(0, 0)$

CHAPTER 5

INTRODUCTION TO EUCLID'S GEOMETRY

BASIC CONCEPTS

- **Introduction** : Euclidean geometry, which is taught today is named after Euclid - he is known as “the father of geometry”. Euclid also studied and contributed in other areas of mathematics, including number theory and astronomy.
- **Axiom or Postulates** : Axiom or Postulates are the assumptions which are obvious universal truths. They are not proved.
- **Theorems** : Theorems are statements which are proved using definitions, axioms, previously proved statements and deductive reasoning.

SOME OF EUCLID'S AXIOMS

1. Things which are equal to the same thing are equal to one another.
2. If equals are added to equals the whole are equal.
3. If equals are subtracted from equals the remainders are equal.
4. Things which coincide with one another are equal to one another.
5. The whole is greater than the part.
6. Things which are double of the same things are equal to one another.
7. Things which are halves of the same things are equal to one another.

EUCLID'S POSTULATES AND DEFINITIONS

- **Postulate 1** : A straight line may be drawn from any one point to any other points.
- **Postulate 2** : A terminated line can be produced in definitely.
- **Postulate 3** : A circle can be drawn with any centre and any radius.
- **Postulate 4** : All right angles are equal to one-another.
- **Postulate 5** : If a straight line falling on two straight lines makes the interior angles on the same side of it taken together less than two right angles, then two straight lines if produced indefinitely, meet on that side on which the sum of angles is less than two right angles.

DEFINITIONS

1. A Point is that which has no part.
 2. A line is breadth less length
 3. The ends of a line are points.
 4. A straight line is a line which lies evenly with the points on it self.
 5. A surface is that which contain length and breadth only.
 6. The edges of a surface are lines.
 7. A plane surface is a surface which lies evently with the straight lines on it self
- Two distinct lines can not have more than one point in common.

CHAPTER 5

INTRODUCTION TO EUCLID'S GEOMETRY**PART – A**

1. Write the number of dimensions, that a surface contain.
2. A proof is required for _____ (Postulate, Axioms, Theorem).
3. The number of line segments determined by three collinear points is _____ (Two, three, only one).
4. Euclid stated that if Equals are subtracted from Equal then the remainders are equal in the form of _____ (an axiom, a definition, a postulate).
5. In given figure $AD = BC$ then AC and BD are equal or not.

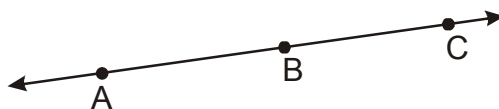

6. How many lines can pass through a single point?
7. State Euclid's first postulate.
8. Write Euclid's fifth postulate.
9. If $a + b = 15$ and $a + b + c = 15 + c$
which axiom of Euclid does the statement illustrate?
10. If A, B and C are three points on a line and B is between A and C then prove that $AC - BC = AB$.

**PART – B**

11. If $x + y = 10$ and $x = z$ then show that $z + y = 10$
12. In given figure $AX = AY$, $AB = AC$ Show that $BX = CY$
Show that : $BX = CY$

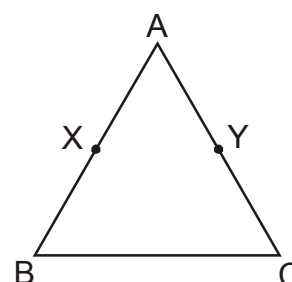

13. In the given figure of $AD = CB$
then prove that $AC = BD$

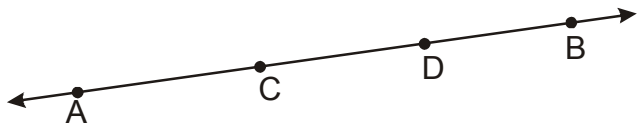

14. Solve the equation $x - 10 = 15$, State which axiom do you use here.
15. If a point C lies between two points A and B such that $AC = BC$ then prove that

$$AC = \frac{1}{2} AB$$

16. In the given figure

$$AM = \frac{1}{2} AB$$

$$AN = \frac{1}{2} AC$$

show that $AB = AC$

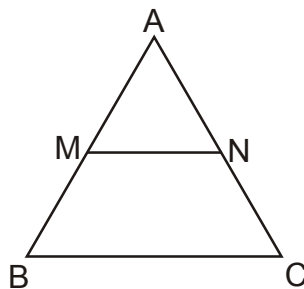

17. In the given figure $AC = DC$, $CB = CE$
then show that $AB = DE$

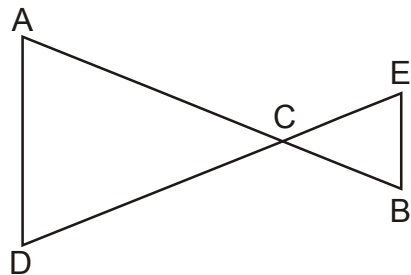

18. Prove that every line segment has one and only one mid point.
19. State true or false
(a) only one line can pass through a single point.
(b) There are infinitely many number of lines which passes through the two distinct point.
(c) Euclid belongs to Greece.

20. In the given figure $\angle 1 = \angle 2$ and $\angle 2 = \angle 3$
then show that $\angle 1 = \angle 3$

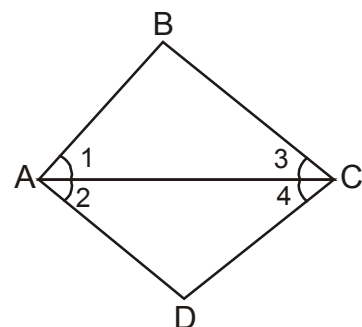

21. In the give figure $\angle 1 = \angle 3$ and $\angle 2 = \angle 4$
then show that $\angle BAD = \angle BCD$

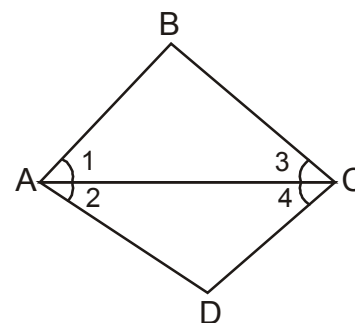

22. An equilateral triangle is a polygen made up of three line segment out of which two line segments are equal to the third one and all the angles are 60° each.
Can you justify that all sides and all angles are equal in equilateral triangle.
23. RAM and Shyam are two students of Class IX. They give equal donation to a blind school in the month of March. In April each student double their donation.
- compare their donation in April.
 - what values are depicted in the question
 - which mathematical concept have been covered in this question?
24. Monika and Vasu have the same weight if they each gain weight by 2kg. How will their new weights be compared?
- what values are depicted in this question?
 - What mathematical concept have been covered in this question?

ANSWER

- | | | | |
|--|-------------|--------------------|------------------|
| 1. Two | 2. Theorem | 3. Only one | 4. Axiom |
| 5. Equal | 6. Infinite | 9. Second axiom | 14. Second Axiom |
| 19. (a) false | (b) false | (c) True | |
| 23. (a) Donation amount is same in April | | | |
| (b) Helpful Humanity; | | (c) Euclid's axiom | |
| 24. (a) logical reasoning | | (b) Euclid's axiom | |

CHAPTER 6

LINES AND ANGLES

BASIC CONCEPTS

- Line is a collection of points which has only length not breadth and thickness.
- **Line Segment** : A part or portion of a line with two end points.
- **Ray** : A part of a line with one end point.
- **Collinear points** : Three or more points lying on the same line.
- **Angle** : An angle is formed when two rays originate from the same end point. The rays making an angle are called the arms and the end point is the vertex.
- **Acute angle** : An angle measure between 0° and 90°
- **Right angle** : Angle exactly equal to 90°
- **Obtuse angle** : An angle greater than 90° but less than 180°
- **Straight angle** : An angle exactly equal to 180°
- **Reflex Angle** : An angle greater than 180° but less than 360°
- **Complimentary Angles** : A pair of angles whose sum is 90°
- **Supplementary angle** : A pair of angles whose sum is 180°
- **Adjacent angles** : Two angles are adjacent if
 - (i) They have a common vertex.
 - (ii) a common arm
 - (iii) Their non common arms are on opposite sides of common arm.
- **Linear pair of angle** : A pair of adjacent angles whose sum is 180°
 $\angle AOB$ & $\angle COB$ are making linear pair of angle

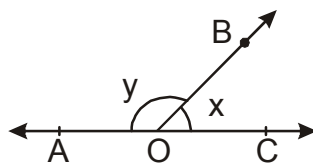

$\angle AOB$ & $\angle COB$ are forming linear pair

- **Vertically opposite angles** : Angles formed by two intersecting lines on opposite side of the point of intersection

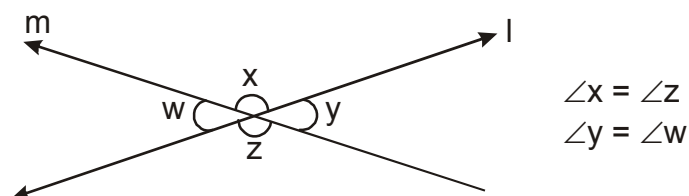

- **Intersecting line** : Two lines are said to be intersecting when the perpendicular distance between the two lines is not same every where. They meet at one point.
- **Non Intersecting lines** : Two lines are said to be non-intersecting lines when the perpendicular distance between them is same every where. They do not meet. If these lines are in the same plane these are known as **Parallel lines**.
- **Transversal line** : In the given figure $l \parallel m$ and t is transversal then

(a) $\left. \begin{array}{l} \angle 1 = \angle 3 \\ \angle 2 = \angle 4 \\ \angle 5 = \angle 7 \\ \angle 6 = \angle 8 \end{array} \right\}$ Vertically opposite angle

(b) $\left. \begin{array}{l} \angle 1 = \angle 5 \\ \angle 2 = \angle 6 \\ \angle 3 = \angle 7 \\ \angle 4 = \angle 8 \end{array} \right\}$ Corresponding angle

(c) $\left. \begin{array}{l} \angle 3 = \angle 5 \\ \angle 4 = \angle 6 \end{array} \right\}$ Alternate Interior angle

(d) $\left. \begin{array}{l} \angle 3 + \angle 6 = 180^\circ \\ \angle 4 + \angle 5 = 180^\circ \end{array} \right\}$ Angles on the same sides of a transversal are supplementary.

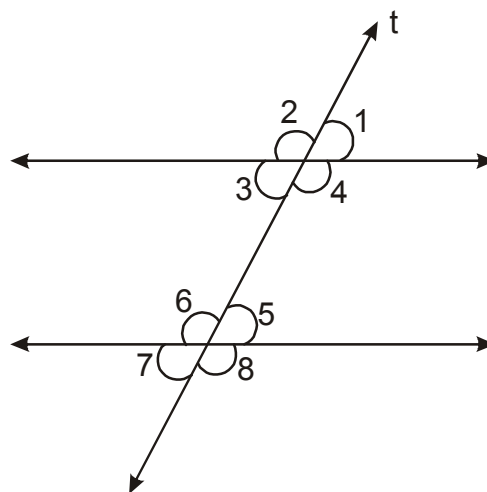

$\angle 3, \angle 6$ and $\angle 4, \angle 5$ are called co-interior angles or allied angles or consecutive interior angles.

- Sum of all interior angles of a triangle is 180° .

CHAPTER 6

LINES AND ANGLES

PART - A

1. From the figure find x and y

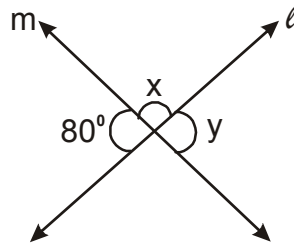

2. If an angle is equal to its complement find the angle.
 3. In the adjoining figure if $l \parallel m$ and t is transversal, find the value of x .

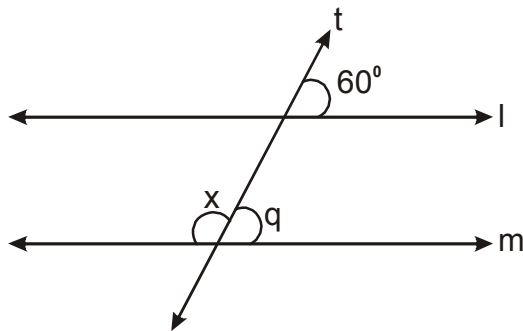

4. In the figure POQ is a straight line. The three adjacent angles are consecutive numbers. What are the measure of these angles.

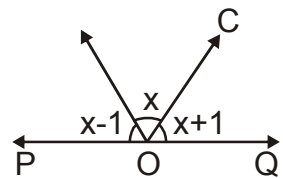

5. Twice of x is 30° less than y find x & y from figure.

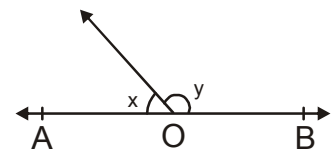

6. In the adjoining figure if $AB \parallel CD$ what is the value of p .

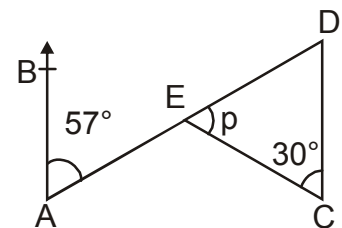

7. In the adjoining figure find that value of $a + b$ if $\angle DBE = 90^\circ$

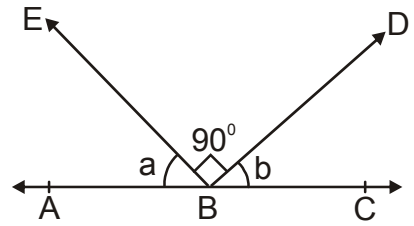

8. In the figure $l \parallel m$ find $\angle y$

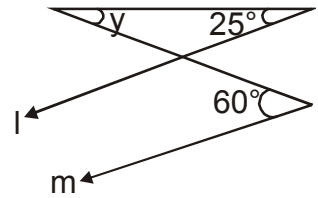

9. If $p : q = 11 : 19$, $AB \parallel CE$ what are the values of p , q & r .

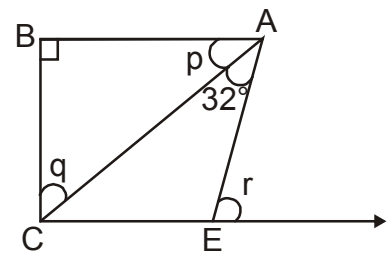

10. What is x in the figure?

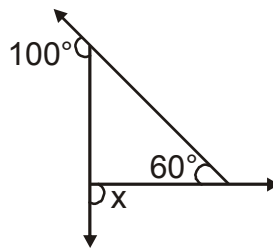

11. One of the angle of a pair of supplementary angles is 2^3 more than its supplement find the angles.
12. In the figure CD is the angle bisector of $\angle C$, $\angle B = \angle ACE$.
Prove that $\angle ADC = \angle ACD$

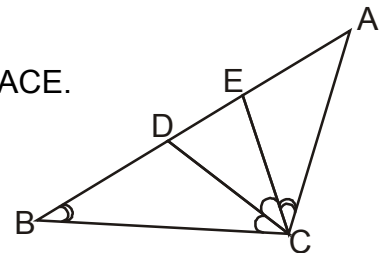

PART - B

13. In the adjoining figure $PQ \parallel RS$ find x and y .

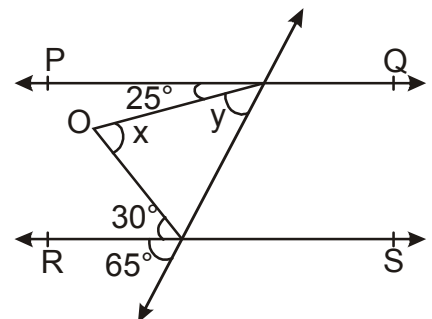

14. By contributing money 5 friends bought pizza. They want to divide it equally among them selves. But one of them was given double piece, as he was very hungry. Find the angle of the piece of pizza each one received.

15. BO and CO are external bisector of $\angle B$ and $\angle C$ of a $\triangle ABC$ Intersecting at O. If $\angle A = 60^\circ$ $\angle ABC = 70^\circ$, find $\angle BOC$.
16. In the above question 15, if Internal bisector of $\angle B$ and $\angle C$ intersect at P. Prove that $\angle PBO = 90^\circ$ and $\angle BOC + \angle BPC = 180^\circ$

17. In the given figure if $l \parallel m$ and 't' is the transversal find x.

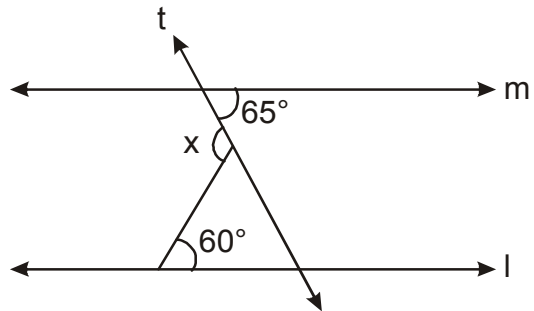

18. An exterior angle of triangle is 103° and two of its interior opposite angles are equal, find the angles.

19. Prove that vertically opposite angles are equal.

20. In the figure $AB \parallel CD$ and $EF \parallel BD$ if $\angle CDB = 100^\circ$, find $\angle AEF$

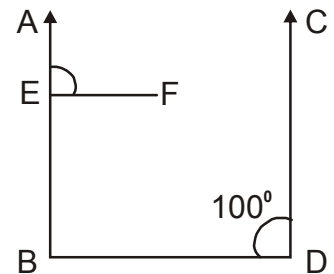

21. In the given figure $l \parallel m$ find the value of x

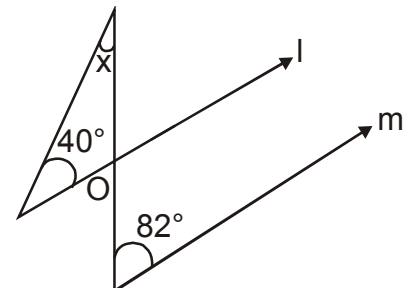

22. The angle of a triangle are $(x - 40^\circ)$, $(x - 20^\circ)$, $(\frac{x}{2} - 10^\circ)$

Find the value of x and then find the angles of the triangle.

23. In the given figure if $AB \parallel DC$ and $\angle BDC = 30^\circ$ $\angle BAD = 80^\circ$ find $\angle x$, $\angle y$, $\angle z$.

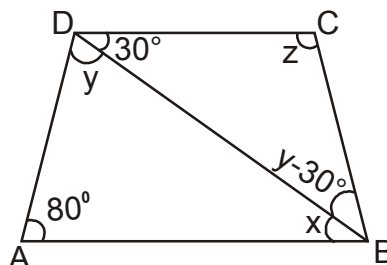

PART - C

24. In the figure O is the location of the mother dairy from where the milk is to be supplied to the four booths A, B, C & D. If the angle between booth B & C, and C & D and D & A are in the ratio 2 : 1 : 3, find the angles.

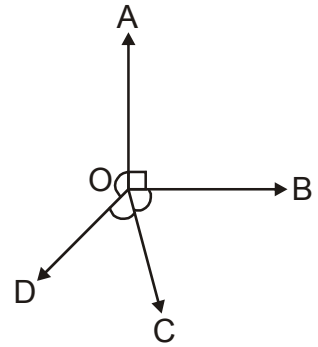

25. If $p \parallel q \parallel r$, find x, y, z from given figure.

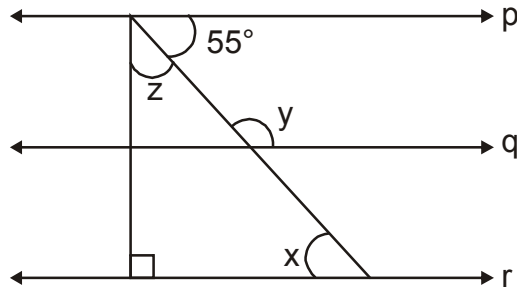

26. In the given figure find $\angle DCB$ if $AE \parallel CD$

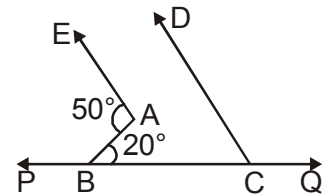

27. In the given figure $l \parallel m$ find x .

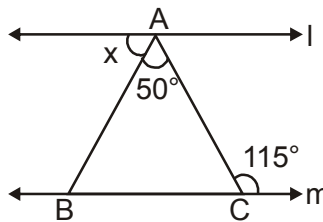

28. In the given figure $l \parallel m$ and n is the transversal, find x .

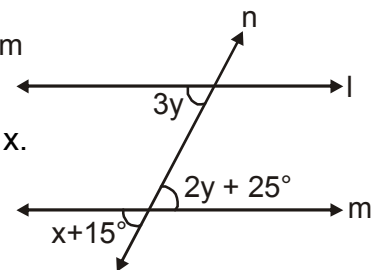

29. For what value of x , $l \parallel m$.

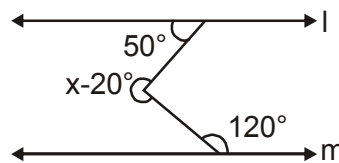

30. From the figure find reflex angle $\angle BOC$ if $AB \parallel CD$.

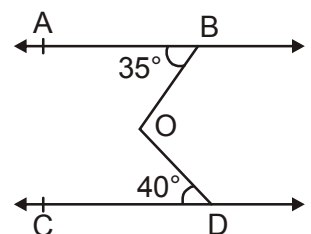

31. If the angle of triangle are in the ratio 5 : 3 : 7 then show that the triangle is acute angled triangle.

32. Two lines are respectively perpendicular to two parallel lines show that they are parallel to each other.

33. As shown in the figure find x & y if $\angle ACB = 100^\circ$, $\angle ADE = 120^\circ$.

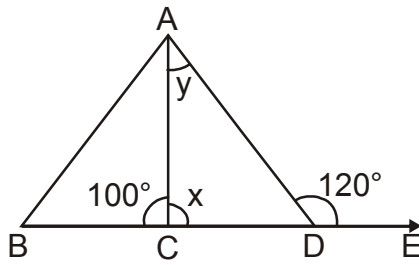

34. In the given figure $\angle DOB = 85^\circ$, $\angle COA = 85^\circ$, $\angle BOA = 40^\circ$, find $\angle COB$ and $\angle DOC$

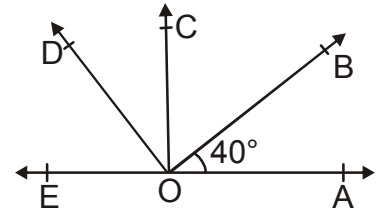

35. Prove that the bisector of the angles of a linear pair are at right angle.
36. If two complementary angles are such that two times the measure of one is equal to three times the measure of the other. Find the measure of larger angle.
37. Prove that the sum of all exterior angles of a triangle is 360° .
38. If the bisectors of $\angle Q$ and $\angle R$ of a triangle $\angle PQR$ meet at points, then prove that

$$\angle QSR = 90^\circ + \frac{1}{2} \angle P$$

PART – D

39. If a transversal intersects two parallel lines prove that internal bisectors of the angle on the same side of a transversal meet at right angles.

40. In the given figure PQ, RS are two mirrors placed parallel to each other. An incident ray AB strikes the mirror PQ at B; the reflected ray moves along the path BC again strikes the mirror RS at C and reflects back along CD.

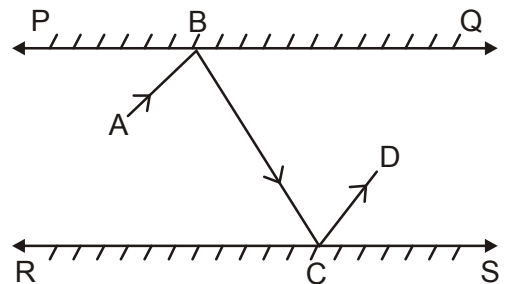

Prove that $AB \parallel CD$.

41. In the figure AE is the bisector of $\angle A$, $AD \perp BC$. Find x .

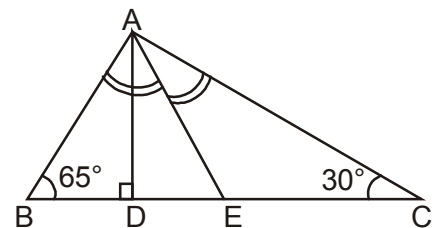

42. Prove that quadrilateral formed by the intersection of bisectors of interior angles made by a transversal on two parallel lines is a rectangle.

43. In the given figure $l \parallel m$ where l and m are the bisectors of corresponding angles $\angle ATQ$, $\angle TUS$. Prove that $PQ \parallel RS$.

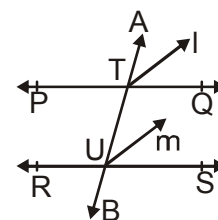

44. POQ is a straight line $RO \perp PQ$, SO is a ray from O then prove that

$$\angle ROS = \frac{1}{2}(\angle QOS - \angle POS)$$

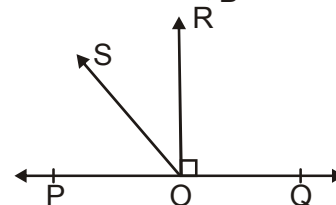

45. A route for going from place A to place C is shown in the adjoining figure. To avoid traffic on the highway AM, a road is cut through S via T to reach C, by authorities. If $\angle MST = 125^\circ$, $\angle CUT = 50^\circ$, what will be the angle at T, $\angle STU$. What values are depicted from above.

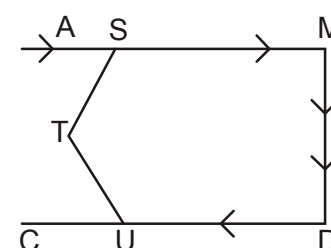

46. In a co-Educational School a teacher conduct a mathematical quiz to solve a question on black board. She needs two students and prize will be given to the students. Who solve the question first. For this purpose she choose a boy and a girl. The problem is given in the figure.

- (i) If $AB \parallel CD$ find x
 (ii) What type of the value is depicted by the teacher in this activity.

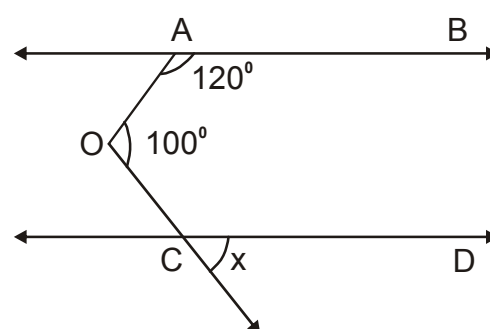

ANSWER

1. $x = 100^\circ, y = 80^\circ$ 2. 45° 3. 120° 4. $59^\circ, 60^\circ, 61^\circ$
5. $50^\circ, 130^\circ$ 6. 93° 7. $a + b = 90^\circ$ 8. 35°
9. $33^\circ, 57^\circ, 65^\circ$ 10. 140° 11. $86^\circ, 94^\circ$ 13. $40^\circ, 55^\circ$
14. $60^\circ \times 4, 120^\circ \times 1$ 15. 17. 125° 18. $51\frac{1}{2}^\circ, 51\frac{1}{2}^\circ$
20. 80° 21. 42° 22. $x = 100, 60^\circ, 80^\circ, 40^\circ$
23. $x = 30^\circ, y = 70^\circ, z = 110^\circ$
26. 30° 27. 65° 28. 60° 30. 285°
33. $80^\circ, 40^\circ$ 34. $45^\circ, 40^\circ$ 36. 54°
41. 17.5°

CHAPTER 7

TRIANGLES**BASIC CONCEPTS**

- Two figures having the same shape and size are called congruent figures.
- Two plane figures are congruent, if each one when superimposed on the other, covers the other exactly.
- Two line segments are congruent, if they are of equal lengths.
- Two angles of equal measures are congruent.
- Two circles of the same radii are congruent.
- Two squares of the same sides are congruent.
- Two rectangles are congruent, if they have the same length and breadth.
- If two triangles ABC and DEF are congruent under the correspondence $A \longleftrightarrow D$, $B \longleftrightarrow E$ and $C \longleftrightarrow F$, then symbolically, it is expressed as $\triangle ABC \cong \triangle DEF$.
- There are four congruence conditions for triangles.
 - (a) **Side-Angle-Side (SAS) congruence rule** : Two triangles are congruent, if two sides and the included angle of the one triangle respectively equal to the two sides and the included angle of the other triangle.
 - (b) **Angle-Side-Angle (ASA) congruence rule** : Two triangles are congruent, if two angles and the included side of the one triangle are respectively equal to the two angles and the included side of the other triangle.
 - (c) **Side-Side-Side (SSS) congruence rule** : Two triangles are congruent, if the three sides of one triangle are respectively equal to the three sides of the other triangle.
 - (d) **Right angle-Hypotenuse-Side (RHS) congruence rule** : Two right triangles are congruent, if the hypotenuse and one side of one triangle are respectively equal to the hypotenuse and one side of the other triangle.
- Angles opposite to equal sides of a triangle are equal.
- Sides opposite to equal angles of a triangle are equal.
- In a triangle, angle opposite to the longer side is larger (greater).
- In a triangle, side opposite to the larger (greater) angle is longer.
- Sum of any two sides of a triangle is greater than the third side.

CHAPTER 7

TRIANGLES

PART – A

- Which of the following is not a congruence criterion for triangles ?
 (a) SSS (b) RHS (c) AAA (d) SAS
- If $\overline{AB} \cong \overline{CD}$ then
 (a) $\overline{AB} < \overline{CD}$ (b) $\overline{AB} + \overline{CD} = 0$ (c) $\overline{AB} = \overline{CD}$ (d) $\overline{AB} > \overline{CD}$
- If $\triangle ABC \cong \triangle DEF$ then
 (i) $AB = \underline{\hspace{2cm}}$ (ii) $BC = \underline{\hspace{2cm}}$ (iii) $CA = \underline{\hspace{2cm}}$ (iv) $\angle E = \underline{\hspace{2cm}}$
 (v) $\angle EDF = \underline{\hspace{2cm}}$ (vi) $\angle BCA = \underline{\hspace{2cm}}$
- Circle $O_1 \cong$ Circle O_2 . If radius of circle $O_1 = 6$ cm then diameter of circle O_2 is _____.

- In the given figure, if $a = b = c$ then $\angle AOC \cong \underline{\hspace{2cm}}$

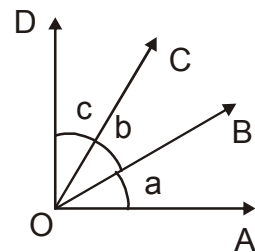

- If $\triangle PQR \cong \triangle DEF$ then $Q \leftrightarrow \underline{\hspace{2cm}}$

- Which is the longest side of the triangle given in the figure?

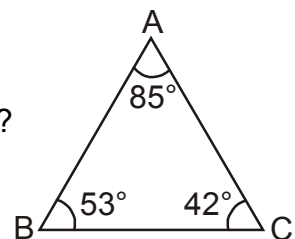

- Which is the largest angle in the $\triangle PQR$?

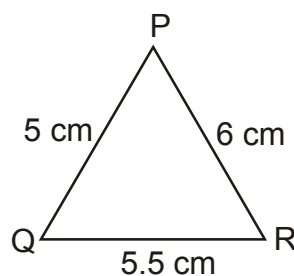

9. Which two triangles are congruent in the given figure. Write them in symbolic form.

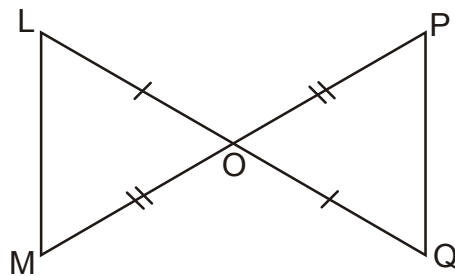

10. Two squares are congruent if they have _____.

PART – B

11. Match the columns :

Column A

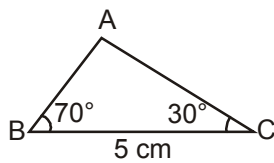
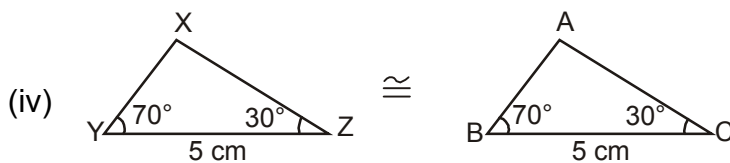
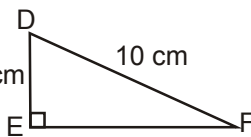
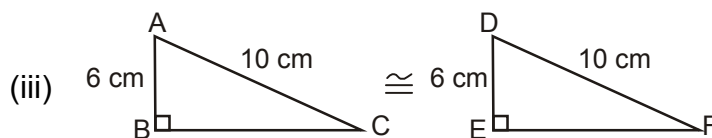
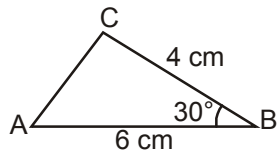
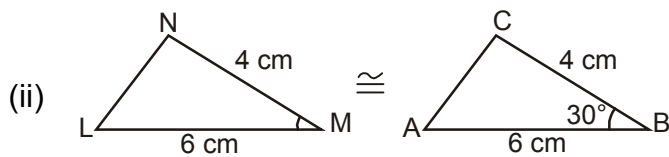
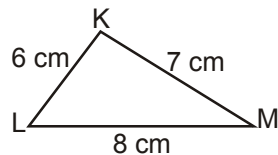
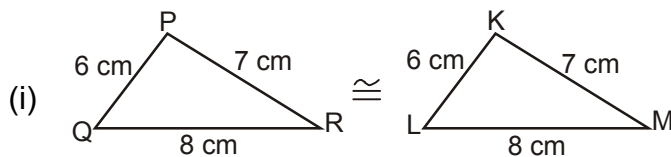

Column B

(a) SAS congruence

(b) SSS congruence

(c) ASA Congruence

(d) RHS congruence

12. Match the columns :

Column A

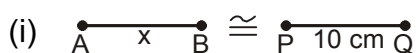

$x = ?$



$x = ?$

Column B

(a) 2 cm

(b) 5 cm

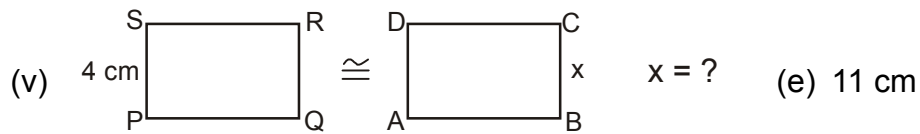
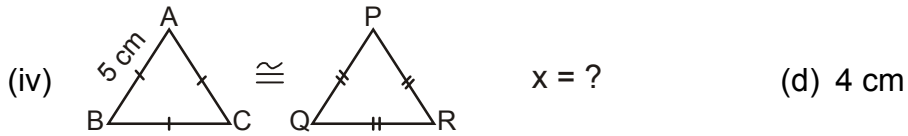
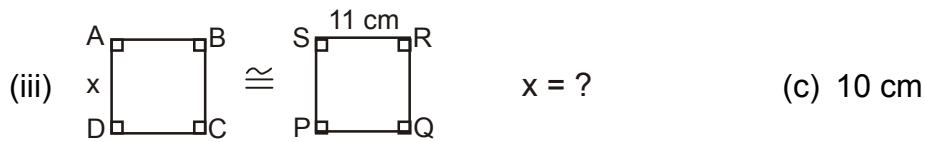

13. In the given figure. If $AB = CD$, $AD = BC$ then prove that $\triangle ADC \cong \triangle CBA$

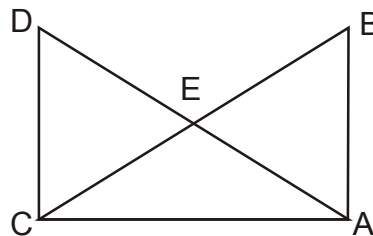

14. If $\triangle ABC$ is an isosceles triangle such that $AB = AC$, then prove that altitude AD from A on BC bisects it.
15. Which criteria of congruence of triangles is satisfied in the given figure.

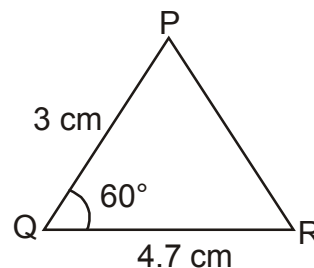
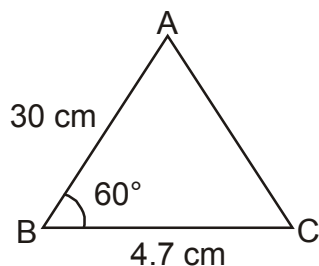

16. In a $\triangle PQR$, $\angle P = 110^\circ$, $PQ = PR$. Find $\angle Q$ and $\angle R$.

17. In the given figure $AB = AC$ and $\angle ACD = 125^\circ$. Find $\angle A$

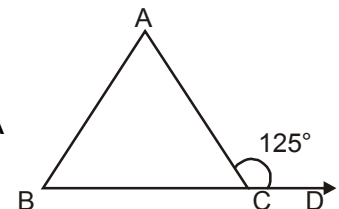

18. In $\triangle ABC$, if $\angle A = 55^\circ$, $\angle B = 75^\circ$ then find out the smallest and longest side of the triangle.

19. In the given figure, AC bisects $\angle A$ and $\angle C$. If $AD = 5$ cm find AB .

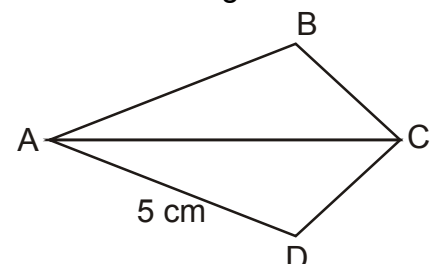

20. The vertex angle of an isosceles triangle is 80° . Find out the measure of base angles.

PART – C

21. In the given figure, Q is a point on the side SR of ΔPSR such that $PQ = PR$. Prove that $PS > PQ$.
22. ABC is a triangle and D is the mid-point of BC. The perpendicular from D to AB and AC are equal. Prove that triangle is isosceles.

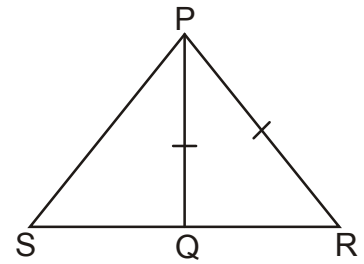

23. Prove that angles opposite to the equal sides of an isosceles triangle are equal.

24. In the given figure, $AC > AB$ and AD bisects $\angle BAC$. Prove that $\angle ADC > \angle ADB$.

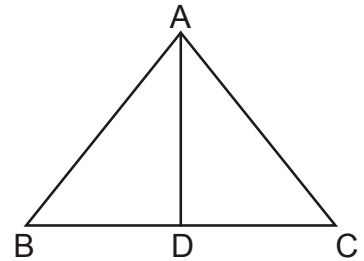

25. S is any point in the interior of a ΔPQR . Prove that $SQ + SR < PQ + PR$.

26. In the given figure, if $AD = BD = CD$. Find $\angle BAC$.

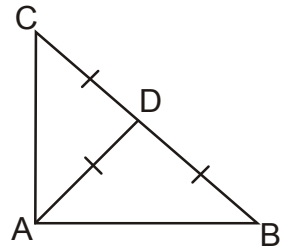

27. In the given figure, if $AB = BC$ and $\angle A = \angle C$ then find the value of x.

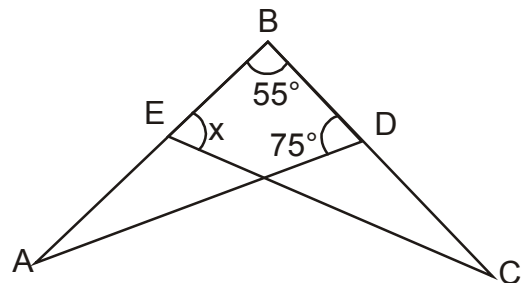

28. In the given figure, $\angle ABC = \angle BAC$, D and E are points on BC and AC respectively. Such that $DB = AE$. If AD and BE intersect at O then prove that $OA = OB$.

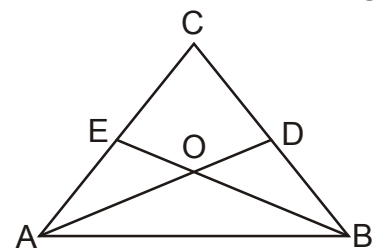

29. In the given figure, if $AB = AC$, $\angle BAD = \angle CAE$ then prove that ΔADE is an isosceles triangle.

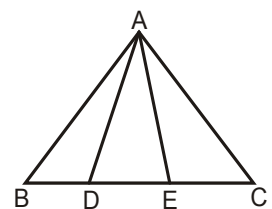

30. In $\triangle DEF$, $\angle E = 2\angle F$. DM is the angle bisector of $\angle EDF$ that intersects EF at M. If $DM = MF$, then prove that $\angle EDF = 72^\circ$.
31. Prove that the angles of an equilateral triangle are 60° each.
32. In the given figure, $\angle a > \angle b$, show that $\angle ATM < \angle AMT$.

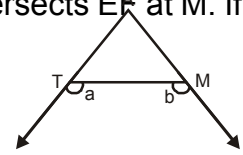

PART – D

33. AF, BD and CE are altitudes of $\triangle ABC$ are equal. Prove that $\triangle ABC$ is an equilateral triangle.
34. Prove that two triangles are congruent if two angles and the included side of one triangle are equal to the two angles and the included side of the other triangle.
35. O is any point in the interior of a $\triangle ABC$. Prove that $OA + OB + OC > \frac{1}{2} (AB + BC + CA)$.
36. Prove that the perimeter of a triangle is greater than the sum of its three altitudes.
37. Two sides AB, BC and median AM of one $\triangle ABC$ are respectively equal to sides PQ, QR and median PN of $\triangle PQR$. Show that :

- (a) $\triangle ABM \cong \triangle PQN$ (ii)
 $\triangle ABC \cong \triangle PQR$

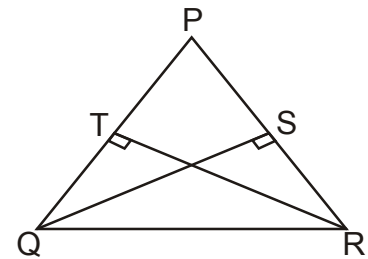

38. In the given figure, PQR is a triangle in which altitudes QS and RT to sides PR and PQ are equal. Show that
- (i) $\triangle PQS \cong \triangle PRT$
- (ii) PQR is an isosceles triangle

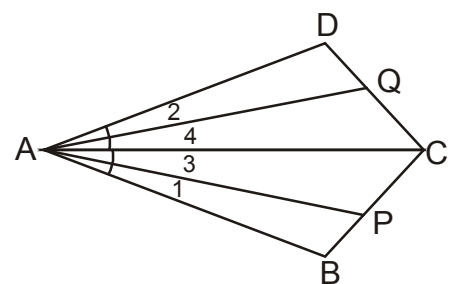

39. In the given figure, $AB = AD$, $\angle 1 = \angle 2$ and $\angle 3 = \angle 4$. Prove that $AP = AQ$.

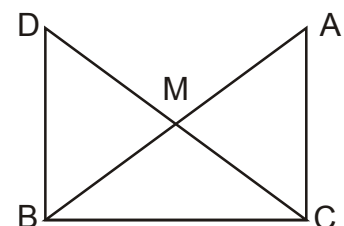

40. In the given figure, ABC is a right angled triangle, right angled at C, M is the mid-point of hypotenuse, AB. C is joined to M and produced to a point D such that $DM =$

CM. D is joined to B prove that $CM = \frac{1}{2} AB$.

41. Ram has a land in the shape of a square PQRS. Its diagonals PR and QS intersect at O. Show that $\triangle POQ \cong \triangle QOR \cong \triangle ROS \cong \triangle SOP$

Ram donates two triangular parts of land for opening a hospital and a school. Which values are exhibited by Ram?

42. Vandana wishes to literate the poor children of the nearby slum area. She makes flash cards for them as shown in the given figure.

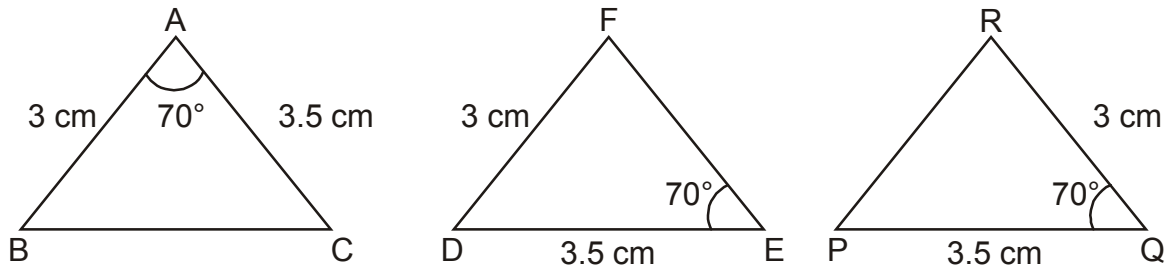

- (a) Which two flash cards are congruent?
 (b) Which criteria of congruency is satisfied here?
 (c) Which values are depicted by Vandana?
43. Pravesh with his friends made kites for orphanage children for Independence day celebration. He posted orange strip on the longest side of $\triangle ABD$.

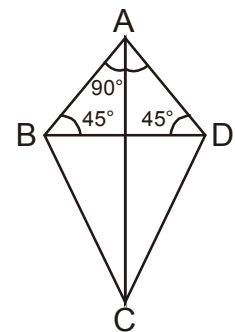

- (a) Which is the longest side of $\triangle ABD$ of Kite?
 (b) What values are exhibited by Pravesh and his friends by performing such activity.

ANSWERS

1. (c)
2. (c)
3. (i) DE (ii) EF (iii) FD (iv) $\angle B$
(v) $\angle BAC$ (vi) $\angle EFD$
4. 12 cm
5. $\angle BOC$
6. E
7. BC
8. $\angle Q$
9. $\triangle LOM \cong \triangle QOP$
10. same side length
11. (i) (b) (ii) (a) (iii) (d) (iv) (c)
12. (i) (c) (ii) (a) (iii) (e) (iv) (b)
(v) (d)
15. SAS
16. $\angle Q = \angle R = 35^\circ$
17. $\angle A = 70^\circ$
18. Smallest side = AB
Longest side = AC
19. AB = 5 cm
20. $50^\circ, 50^\circ$
26. $\angle BAC = 90^\circ$
27. 75°
41. Charity, Care for society etc.
42. (a) (i) and (iii)
(b) $\triangle ABC \cong \triangle QRP$ (SAS Congruency)
(c) Social Value etc.
43. (a) BD (b) Social Values etc.

CHAPTER 12

HERON'S FORMULA

BASIC CONCEPTS

- **Rectangle** : If length and breadth of a rectangle is 'l' and 'b' respectively then

- (i) Perimeter of rectangle = $2(l + b)$
- (ii) Area of rectangle = $l \times b$
- (iii) Diagonal of rectangle = $\sqrt{l^2 + b^2}$

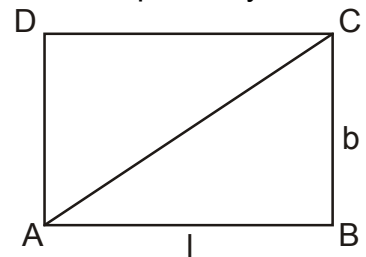

- **Square** : If 'a' is the length of side of a square

- (i) Perimeter of square = $4a$
- (ii) Area of square = $(\text{side})^2 = (a)^2$
- (iii) Area of square = $\frac{1}{2} \times (\text{diagonal})^2$

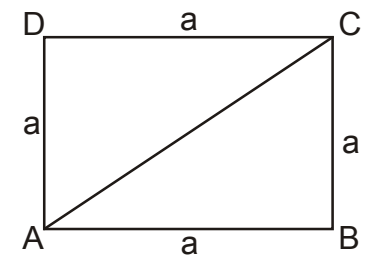

- **Triangle** :

- (A) **Equilateral Triangle** : In this triangle all three sides are equal. If the length of each side is 'a'

- (i) Perimeter = $3a$
- (ii) Altitude = $\frac{\sqrt{3}}{2} a$
- (iii) Area = $\frac{\sqrt{3}}{4} a^2$ or $\frac{\sqrt{3}}{4} (\text{side})^2$

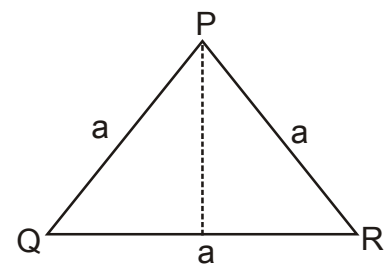

- (B) **Right Angled Triangle** : When an angle is of 90° of a triangle.

- (i) Hypotenuse $K = \sqrt{b^2 + h^2}$
- (ii) Perimeter = $b + h + k$
- (iii) Area = $\frac{1}{2} \times b \times h$

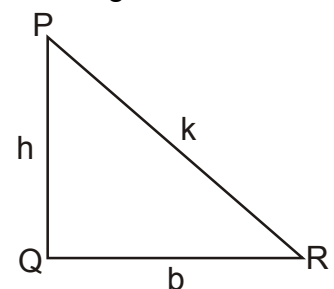

Area of triangle (General Formula)

$$= \frac{1}{2} \times \text{base} \times \text{Corresponding Altitude}$$

$$= \frac{1}{2} \times b \times h$$

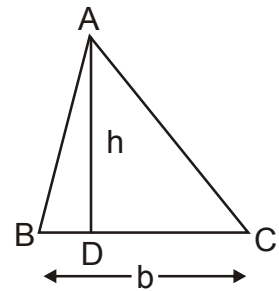

HERON'S FORMULA FOR ANY TYPE OF TRIANGLE

- The sides of triangle are a, b and c

(i) Perimeter = $a + b + c$

(ii) Semi Perimeter (S) = $\frac{a + b + c}{2}$

(iii) Area of Triangle (ΔABC) = $\sqrt{s(s - a)(s - b)(s - c)}$

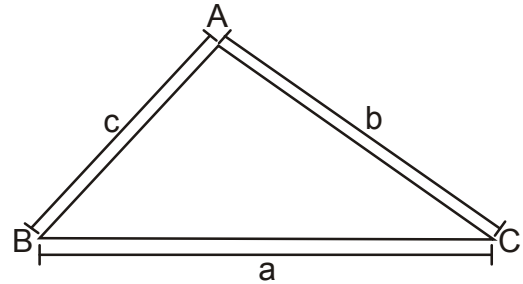

Note : Heron's formula is applicable to all types of triangle.

- **Area of Parallelogram :** If a is the length and b is breadth of a parallelogram and h be the height or perpendicular distance between two parallel sides then.

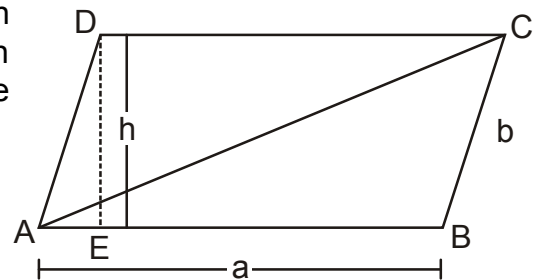

Area of parallelogram (ABCD) = Base \times Corresponding Height

$$= AB \times DE$$

$$= a \times h$$

Area of $\Delta ABC = \frac{1}{2} \times$ Area of Parallelogram

- **Area of Trapezium :** Trapezium with parallel sides a and b and the perpendicular distance between two parallel sides as h.

Area of trapezium

$$= \frac{1}{2} \times (a + b) \times h$$

$$= \frac{1}{2} \times (\text{sum of parallel sides}) \times \text{height}$$

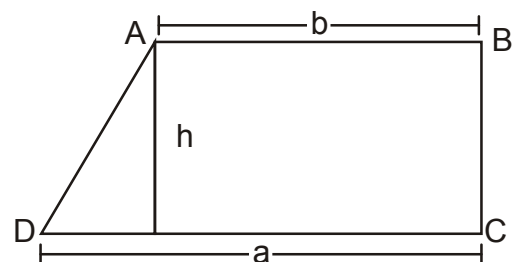

CHAPTER 12

HERON'S FORMULA

PART – A

1. Find the area of a triangle whose base and altitudes are 8 cm and 5 cm.
2. Find the area of an equilateral triangle whose sides are 4 cm each.
3. If sum of two sides of a triangle is 17 cm and its perimeter is 30 cm, then what is the length of third side.
4. If perimeter of a triangle is 24 cm and sides are in the ratio 2 : 1 : 3, then find the longest side ?
5. If each sides of a triangle is doubled then how many times the area of triangle increased?
6. If area of a triangle is 50 cm^2 and one of its sides is 10cm then find the length of corresponding altitude.
7. The area of an equilateral triangle is $16\sqrt{3} \text{ cm}^2$ then what will be the length of each side of that triangle?
8. Find the ratio between the area $\triangle ABC$ and area $\triangle ACD$ of the given rectangle.

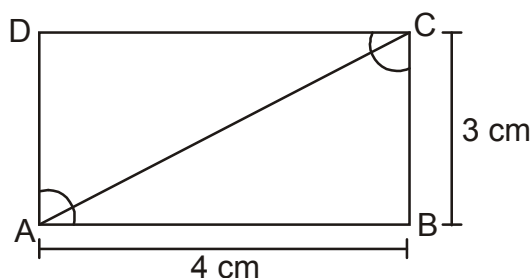

9. A square has each side of 5 cm. Find the length of one of its diagonals.
10. If a parallelogram has length is 10 cm and 8 cm then find the area of a triangle made by its diagonal.
11. If area of a triangle is doubled to its area then what is the percentage increased in the area of triangle?
12. If one side of a triangle is 9.5 m and its corresponding altitude is 12 m then what will be the area of triangle.

PART B

13. The ratio between the sides of a triangle are 3 : 5 : 7 and its perimeter is 300 cm find the sides of triangle.
14. Find the cost of fencing the ground in the form of a triangle with sides 16 m, 12 m and 18 m. The rate of fencing is Rs. 25 per meter.
15. Find the area of isosceles triangle whose non equal sides of 12 cm having the corresponding altitude is 7.5 cm.
16. In a right angled triangle the sides make the right angle are 10 cm and 24 cm. Find the area of triangle.
17. Find the area of rhombus in which AB = 5 cm and AC = 8 cm.

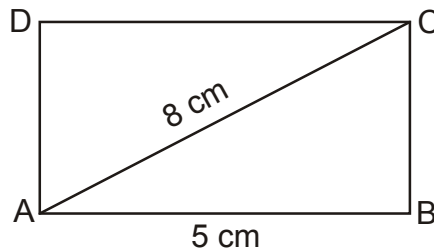

18. If in a triangle AB = 15 cm, BC = 14 cm and AC = 13 cm. Find the area of $\triangle ABC$ and hence its altitude on BC.
19. Show that Area of an equilateral triangle is $\frac{\sqrt{3}}{4} x^2$, Where side is x.
20. Two sides of a parallelogram LMNO are 7 cm and 10 cm one of its diagonal is 13 cm. Find the area of the parallelogram.

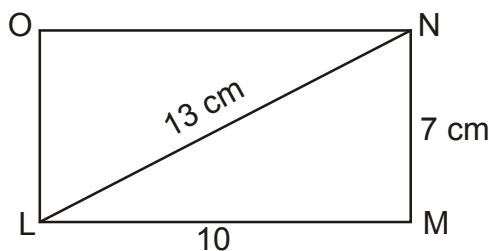

PART - C

21. The diagonals of a rhombus are 10 cm and 24 cm. Find its area and perimeter.
22. Find the area of a triangle or region whose sides are 1.6 m, 1.2 m and 2.0 m.
23. The perimeter of a triangle shaped ground is 420 m and its sides are in the ratio 6 : 7 : 8. Find the area of ground.

24. Find the area of shaded region in the figure.

Use $\sqrt{105} = 10.25$

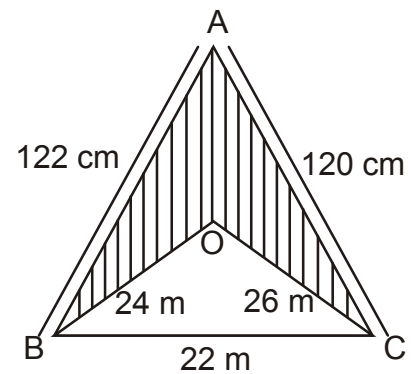

25. Find the area of rhombus whose perimeter is 100 m and one of whose diagonal is 30 m.
26. The sides of a triangle 5 cm, 12 cm and 13 cm. Find the cost of painting on the triangle at the rate of Rs. 30 per cm^2 .
27. An umbrella is made by stitching 6 triangular pieces of cloth of red and black colours each measuring 20 cm, 50 cm and 50 cm. How much cloth of each colour is required for umbrella ?

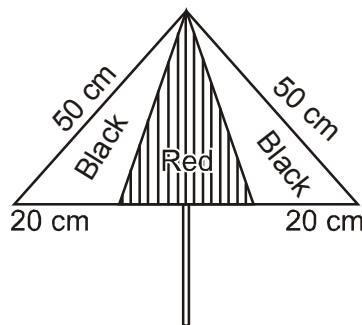

28. Find the ratio between the area of triangle $\triangle ABC$ and $\triangle DEF$.

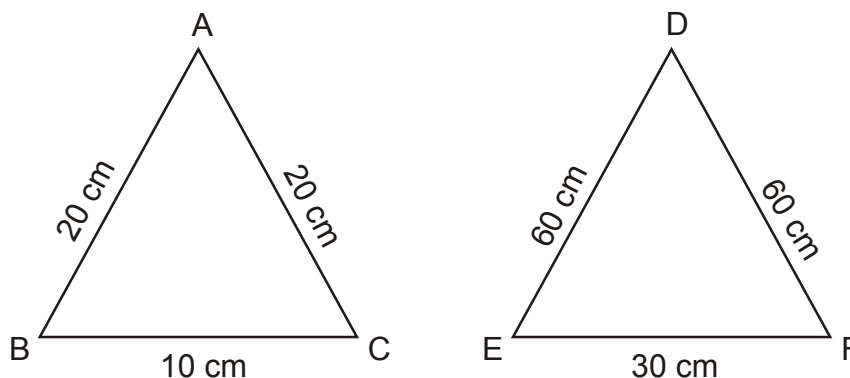

29. If perimeter of a triangle is x cm and its sides are p , q and r cm. What will be the area of triangle. Use the Heron's formula.

PART – D : HERON’S FORMULA

30. A Triangular park ABC has sides 120 m, 80m and 50 m. A gardner Dhani Ram has to put a fence all around it and also plant some trees inside the garden to get clean air.
- (i) Find the cost of fencing it at the rate of Rs. 50 per meter. Leaving space 5 cm wide for the gate on one side.
 - (ii) Find its area where Dhani Ram may plant the tree.
 - (iii) What values of Dhani Ram do you assess here.
31. A piece of land is in the shape as given in the figure, has been cut along diagonal AC. The two pieces of land has been distributed between Ram and Sohan. Who will get larger piece of land in terms of area? [Use $\sqrt{10} = 3.15$]

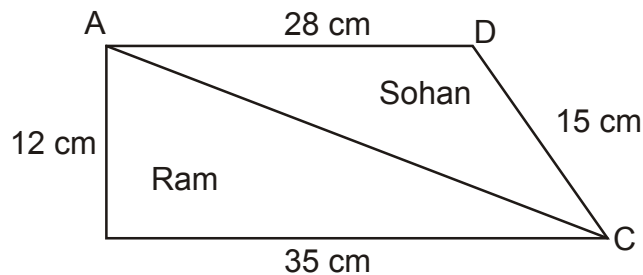

32. A triangular hoarding of dimension 11m, 6m and 15m is used for commercial activities. The hoarding yield an earning of Rs. 5000 per m² per month.
- Calculate the total earning by the hoarding in a month. [Use $\sqrt{2} = 1.7$]
33. A cake is in the form of quadrilateral with sides 6 cm, 8 cm, 6 cm and 6 cm is cut into two parts along its diagonal PR. Part I is given to Ram and II part given to Shashi.
- (i) Is this distribution fair? Justify.
 - (ii) Which geometrical concept is used here.

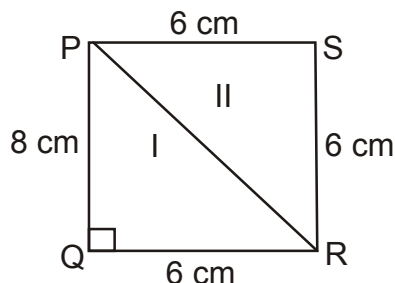

ANSWER

- | | | | |
|---------------------------|--|---------------------------------|------------------------|
| 1. 20 cm ² | 2. $4\sqrt{3}$ cm ² | 3. 13 cm | 4. 12 cm |
| 5. 3 times | 6. 10 cm | 7. 8 cm | 8. 1 : 1 |
| 9. $5\sqrt{2}$ cm | 10. 40 cm ² | 11. 100% | 12. 57 m ² |
| 13. 60 cm, 100 cm, 140 cm | 14. Rs. 1150 | 15. 45 cm ² | |
| 16. 120 cm ² | 17. 12 cm ² | 18. 84 cm ² , 12 cm | |
| 19. — | 20. $40\sqrt{3}$ cm ² | 21. 120 cm ² , 52 cm | |
| 22. 0.96 m ² | 23. $2100\sqrt{15}$ m ² | 24. 1074 m ² | 25. 300 m ² |
| 26. Rs. 900 | 27. $600\sqrt{6}$ cm ² each | 28. 1 : 9 | |
29. $\sqrt{\frac{x}{2}\left(\frac{x}{2} - p\right)\left(\frac{x}{2} - q\right)\left(\frac{x}{2} - r\right)}$
30. (i) Rs. 12250 (ii) $375\sqrt{15}$ m²
 (iii) Caring about environment clean air etc.
31. Ram 210 m² 32. Rs., 5,10,000
33. (i) Not Proper (ii) Area of triangle or Mensuration or Heron's formula.

SUMMATIVE ASSESSMENT-I

PAPER - I

SUBJECT : MATHEMATICS

CLASS : IX

[Time : 3 Hrs.]

[M.M. : 90]

General Instruction :

- (i) All questions are compulsory.
 - (ii) The question paper consists of 31 questions divided into four sections A, B, C and D. Section 'A' comprises of 4 questions of 1 mark each; section 'B' comprises of 6 questions of 2 marks each; section 'C' comprises of 10 questions of 3 marks each and section 'D' comprises of 11 questions of 4 marks each.
 - (iii) There is no overall choice in this question paper.
 - (iv) Use of calculator is not permitted.
-

SECTION – A

Question number 1 to 4 carry one mark each.

1. Find the value of $(81)^{0.16} \times (81)^{0.09}$ 1
2. Using suitable identity, find $(2 + 3x)(2 - 3x)$. 1
3. In the figure, if $\angle A = 40^\circ$ and $\angle B = 70^\circ$, then find $\angle BCE$. 1

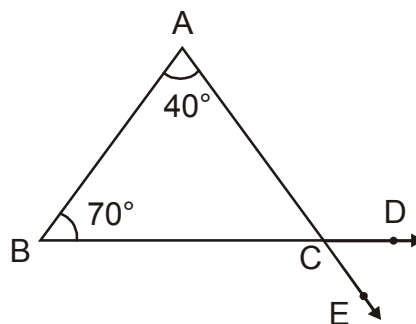

4. In which quadrants the points P(2, -3) and Q(-3, 2) lie? 1
-

SECTION – B

Question numbers 5 to 10 carry two marks each.

5. Find the value of $\sqrt{\frac{2 + \sqrt{3}}{2 - \sqrt{3}}}$, if $\sqrt{3} = 1.73$. 2

6. Using remainder theorem, find the remainder when $x^4 - 3x^3 + 2x^2 - 4$ is divided by $x + 2$. 2

7. In given figure $PR = QS$, then show that $PQ = RS$. Name the mathematician whose postulate/axiom is used for the same.

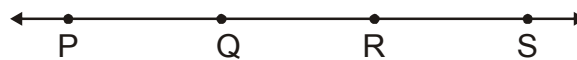

8. In the given figure $\angle B < \angle A$ and $\angle C < \angle D$, show that $AD < BC$. 2

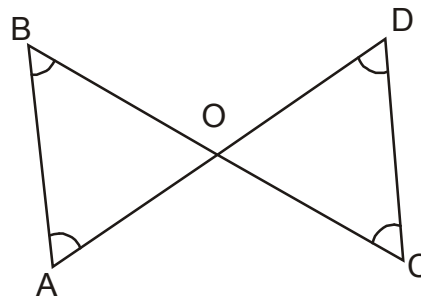

9. Find the perimeter of an isosceles right angled triangle having an area of 5000 m². (Use $\sqrt{2} = 1.41$) 2

10. On which axes the following points lie ? 2

(0, 4), (-5, 0), (5, 0) and (0, -3)

SECTION – C

Question Numbers 11 to 20 carry three marks each.

11. Find the values of a and b, if $\frac{3 + \sqrt{2}}{3 - \sqrt{2}} = a + b\sqrt{2}$ 3

12. Represent $(1 + \sqrt{9.5})$ on the number line. 3

13. Expand $\left(x - \frac{1}{2}y + \frac{1}{3}z\right)^2$ 3

14. Factorise $4x^2 + y^2 + 25z^2 + 4xy - 10yz - 20zx$ and hence find its value when $x = -1$, $y = 2$ and $z = -3$. 3

15. In the figure, $\angle PDQ = 45^\circ$, $\angle PQD = 35^\circ$ and $\angle BOP = 80^\circ$. Prove that $p \parallel m$. 3

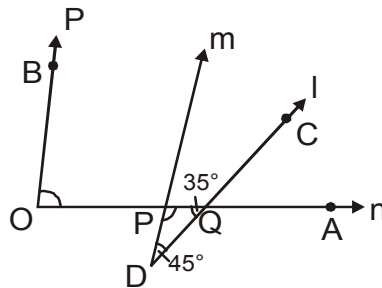

16. In the given figure, show that $XY \parallel EF$. 3

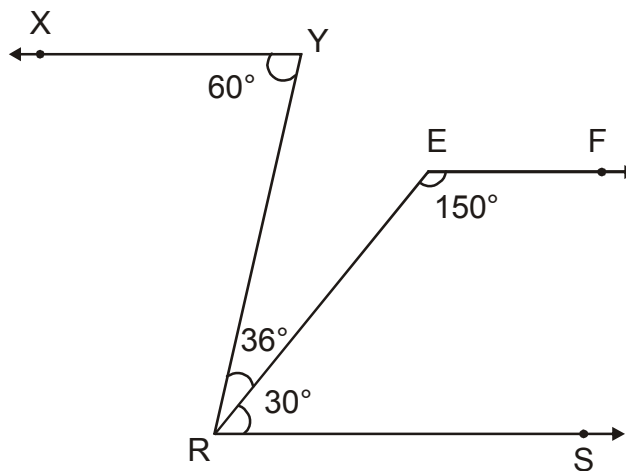

17. In the given figure $AB = AC$. D is a point on AC and E on AB such that $AD = ED = EC = BC$. Prove that $\angle A : \angle B = 1 : 3$. 3

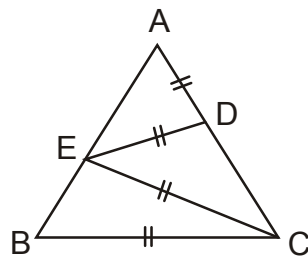

18. In figure, if $l \parallel m$, $\angle 3 = (x + 30)^\circ$ and $\angle 6 = (2x + 15)^\circ$, find $\angle 1$ and $\angle 8$. 3

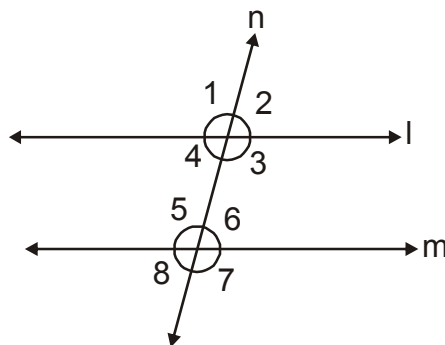

19. Find the area of a triangle whose perimeter is 180 cm and two of its sides are 80 cm and 18 cm. Calculate the altitude of triangle corresponding to its shortest side. 3
20. Plot two point P(0, -4) and Q(0, 4) on the graph paper. Now, plot R and S such that ΔPQR and ΔPQS are isosceles triangles. 3

SECTION – D

Question numbers 21 to 31 carry four marks each.

21. If $x = \frac{\sqrt{2} + 1}{\sqrt{2} - 1}$ and $y = \frac{\sqrt{2} - 1}{\sqrt{2} + 1}$, find the value of $x^2 + y^2 + xy$. 4
22. Prove that : $\frac{1}{3 - \sqrt{8}} - \frac{1}{\sqrt{8} - \sqrt{7}} + \frac{1}{\sqrt{7} - \sqrt{6}} - \frac{1}{\sqrt{6} - \sqrt{5}} + \frac{1}{\sqrt{5} - 2} = 5$ 4
23. Find the value of 'a', if $x + a$ is a factor of the polynomial $p(x) = x^3 + ax^2 - 2x + a + 4$. 4
24. If $(x + 1)$ and $(x + 2)$ are the factors of $x^3 + 3x^2 - 3\alpha x + \beta$, then find α and β . 4
25. Divide the polynomial $x^4 + x^3 - 2x^2 - x + 1$ by $(x + 1)$ and verify remainder by using remainder theorem. 4
26. If $x + y + z = 1$, $xy + yz + zx = -1$ and $xyz = -1$, find the value of $x^3 + y^3 + z^3$. 4
27. A farmer has two adjacent farms PQS and PSR as shown in the figure. He decides to give one farm for hospital. What value is he exhibiting by doing so? If $PQ > PR$ and PS is bisector of $\angle P$, show that $\angle PSQ > \angle PSR$. 4

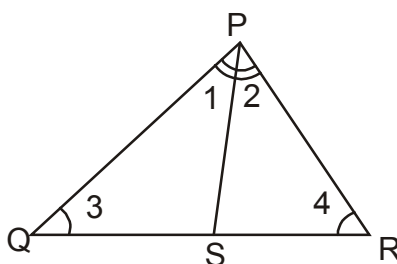

28. In an isosceles triangle ABC with $AB = AC$, D and E are two points on BC such that $BE = CD$. Show that $AD = AE$. 4

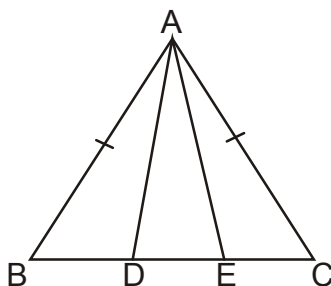

29. In figure, $OA = OD$ and $\angle 1 = \angle 2$. Prove that $\triangle OCB$ is an isosceles triangle. 4

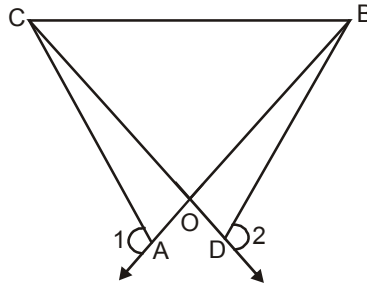

30. Prove that the angle opposite to equal sides of a triangle are equal. 4
31. In the figure, X and Y are the points on equal sides AB and AC of a $\triangle ABC$ such that $AX = AY$. Prove that $XC = YB$. 4

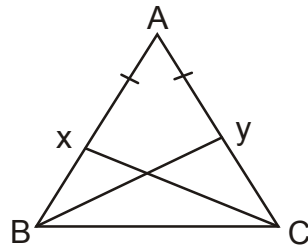

HERON'S FORMULA ANSWER KEY

1. 20 cm^2 2. $4\sqrt{3} \text{ cm}^2$ 3. 13 cm 4. 12 cm
5. 3 times 6. 10 cm 7. 8 cm 8. 1:1
9. $5\sqrt{2} \text{ cm}$ 10. 40 cm^2
11. 100%
12. 57 m^2 13. 60 cm, 100 cm, 140 cm
14. Rs. 1150 15. 45 cm^2 16. 120 cm^2 17. 12 cm^2
18. 84 cm^2 , 12 cm 19. – 20. $40\sqrt{3} \text{ cm}^2$
21. 120 cm^2 , 52cm 22. 0.96 m^2
23. $2100\sqrt{15} \text{ m}^2$ 24. 1074 m^2 25. 300 m^2 26. Rs. 900
27. $600\sqrt{6} \text{ cm}^2$ each 28. 1:9
29. $\sqrt{\frac{x}{2}\left(\frac{x}{2}-p\right)\left(\frac{x}{2}-q\right)\left(\frac{x}{2}-r\right)}$
30. (i) Rs. 12250 (ii) $375\sqrt{15} \text{ m}^2$ (iii) Caring about environment clear air etc.
31. Ram 210 m^2 32. Rs. 510000
33. (i) Not Proper (ii) Area of triangles or mensuration or Heron's formula

SUMMATIVE ASSESSMENT-I

PAPER - II

SUBJECT : MATHEMATICS

CLASS : IX

[Time : 3 Hrs.]

[M.M. : 90]

General Instruction :

- (i) All questions are compulsory.
 - (ii) The question paper consists of 31 questions divided into four sections A, B, C and D. Section 'A' comprises of 4 questions of 1 mark each; section 'B' comprises of 6 questions of 2 marks each; section 'C' comprises of 10 questions of 3 marks each and section 'D' comprises of 11 questions of 4 marks each.
 - (iii) There is no overall choice in this question paper.
 - (iv) Use of calculator is not permitted.
-

SECTION – A

Question number 1 to 4 carry one mark each.

- 1. If $x^{1/12} = 49^{1/24}$, then find the value of x. 1
- 2. If one zero of the polynomial $x^2 - 13x + 40$ is 5, what is the other zero? 1
- 3. In the figure, $\angle A = 80^\circ$, BD and CD are bisectors of $\angle B$ and $\angle C$, then $\angle BDC = ?$ 1

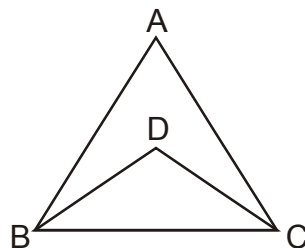

- 4. Write the distance of point S(-3, 6) from y-axis. 1
-

SECTION – B

Question number 5 to 10 carry two marks each.

5. If $x = \sqrt{2} + 1$, then find the value of $x - \frac{1}{x}$ 2
6. Factorise : $\frac{3x^3}{81} - \frac{2y^3}{128} - \frac{x^2y}{12} + \frac{xy^2}{16}$ 2
7. In the figure, find the value of x and hence find $\angle BOD$. 2

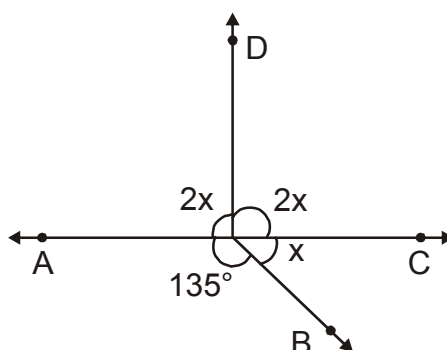

8. Prove that an equilateral triangle can be constructed on any given line segment. 2
9. The longest side of a right angled triangle is 125 m and one of the remaining two sides is 100 m. Find its area using Heron's formula. 2
10. In a rhombus, lengths of diagonals are 400 m and 420 m. Find the side and area of the rhombus. 2

SECTION – C

Question Number 11 to 20 carry three marks each.

11. Represent $2 + \sqrt{4.5}$ on the number line. 3
12. Rationalise the denominator of $\frac{\sqrt{3} + \sqrt{2}}{5 + \sqrt{2}}$. 3
13. The remainder are same when $3x^3 - 4x^2 + kx - 5$ is divided by $(x - 3)$ and $(x + 2)$. Find the value of k . 3
14. If $2x - 5y = 6$, find the value of $8x^3 - 125y^3 - 216 + 180xyz$. 3
15. Prove that : "If the lines intersect, the vertically opposite angles are equal." 3
16. LMN is a triangle in which altitudes MP and NQ to sides LN and LM respectively are equal. Show that : 3

- (i) $\triangle LMP \cong \triangle LNQ$
 (ii) $LM = LN$ i.e., LMN is an isosceles triangle.

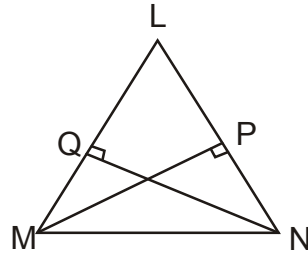

17. In the figure, find $x - y$ if $l \parallel m$, $p \parallel q$. 3

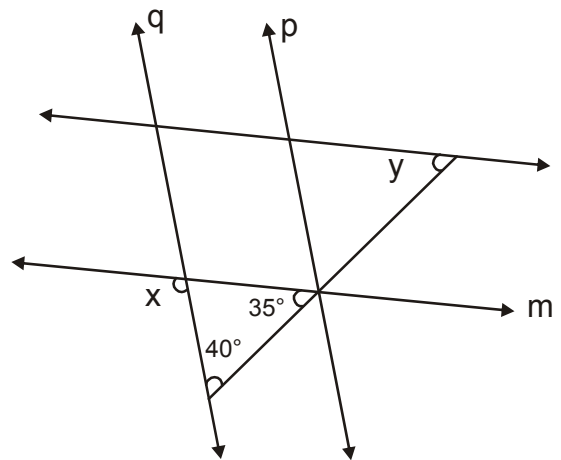

18. In figure, $PQ \parallel ST$, then find $\angle QRS$. 3

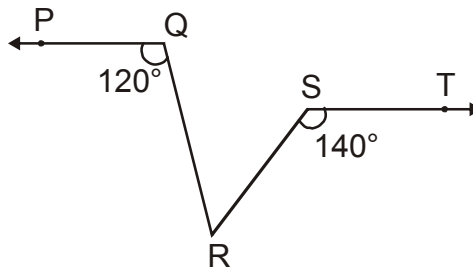

19. Plot the following ordered pairs (x, y) of numbers as points in cartesian plane : 3

x	0	-4.5	-1	2	-3	4
y	2.5	0	3	5	-2	-6

20. Plot the points $(-3, -4)$, $(-5, 0)$ and $(-\frac{3}{2}, \frac{1}{2})$. Also, write the quadrant, axes in which these points lie. 3

SECTION – D

Question numbers 21 to 31 carry four marks each.

21. If $a = 7 - 4\sqrt{3}$, find the value of $\sqrt{a} + \frac{1}{\sqrt{a}}$. 4
22. Simplify : $\frac{2\sqrt{6}}{\sqrt{2} + \sqrt{3}} + \frac{6\sqrt{2}}{\sqrt{6} + \sqrt{3}} - \frac{8\sqrt{3}}{\sqrt{6} + \sqrt{2}}$ 4
23. Find the values of a and b so that $(x + 1)$ and $(x - 1)$ are the factors of $x^4 + ax^3 - 3x^2 + 2x + b$. 4
24. Find the zeroes of $6x^3 + 11x^2 - 12x - 5$. 4
25. By long division, find the quotient $Q(x)$ and remainder $r(x)$, when the polynomial $p(x) = 2x^4 - 5x^3 + 3x - 1$ is divided by $d(x) = 2x - 1$. Show that $p(x) = d(x).Q(x) + r(x)$. 4
26. If $x^4 + \frac{1}{x^4} = 47$, find the value of $x^3 + \frac{1}{x^3}$. Use only positive value of square root. 4
27. Triangles RST and VSU are shown below in which, $\angle R = \angle V$ and $\overline{RT} = \overline{VU}$. Which additional condition is sufficient to prove that $\triangle RST \cong \triangle VSU$? 4

Also prove that $\triangle RST \cong \triangle VSU$.

Triangular regions shown above are the part of land given by an industrialist for a hospital and a school. What value is being exhibited by doing so?

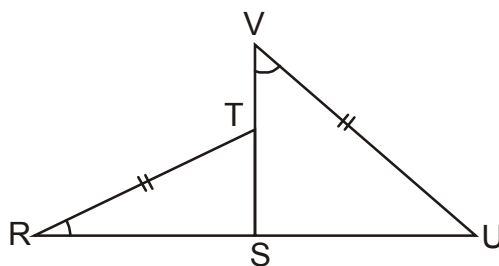

28. If figure, the sides AB and AC of $\triangle ABC$ are produced to points E and D respectively. If bisectors BO and CO of $\angle CBE$ and $\angle BCD$ respectively meet at a point O, then prove that : $\angle BOC = 90^\circ - \frac{1}{2} \angle BAC$. 4

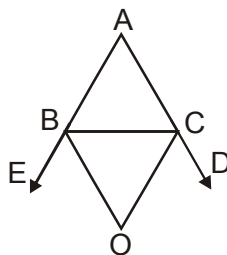

29. Prove that the perimeter of a triangle is greater than the sum of its three medians. 4

30. In the given figure, $\triangle ABC$ is right angled at C and M is the mid-point of hypotenuse AB. C is joined to M and produced to a point D such that $DM = CM$. Point D is joined to B. Show that (i) $\triangle AMC \cong \triangle BMD$ and (ii) $\angle DBC = 90^\circ$. 4

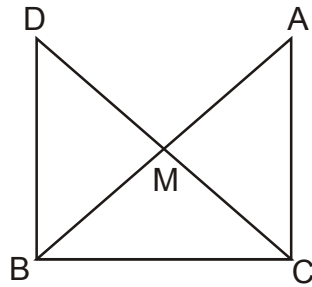

31. In the figure, ABC is an isosceles triangle with $AB = AC$. BD and CE are two medians of the triangle. Prove that $BD = CE$. 4

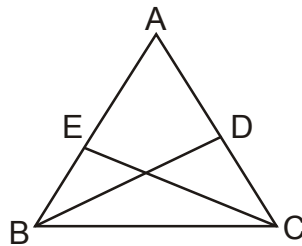

SUMMATIVE ASSESSMENT-I**PAPER - III****SUBJECT : MATHEMATICS****CLASS : IX****[Time : 3 Hrs.]****[M.M. : 90]****General Instruction :**

- (i) All questions are compulsory.
- (ii) The question paper consists of 31 questions divided into four sections A, B, C and D. Section 'A' comprises of 4 questions of 1 mark each; section 'B' comprises of 6 questions of 2 marks each; section 'C' comprises of 10 questions of 3 marks each and section 'D' comprises of 11 questions of 4 marks each.
- (iii) There is no overall choice in this question paper.
- (iv) Use of calculator is not permitted.

SECTION – A**Question number 1 to 4 carry one mark each.**

1. Find the value of $(14641)^{0.25}$. 1
2. Find the value of $p(x) = x^3 - 3x + 5$, when $x = -1$. 1
3. In the given figure $AD \parallel BC$, $\angle BAD = 90^\circ$, $\angle ABD = 25^\circ$ and $\angle DCE = 85^\circ$. Find the measure of $\angle BDC$. 1

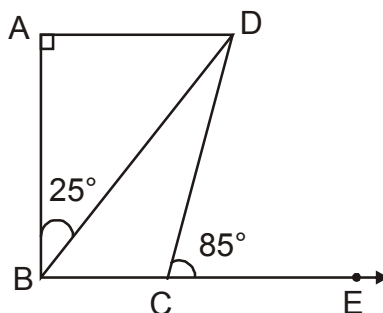

4. Write the quadrant in which the point $(-5, 7)$ lies. 1

SECTION – B

Question number 5 to 10 carry 2 marks each.

5. Find the value of x , if $3^7 \times 3^5 = (3^3)^x$. 2
6. Give possible expression for the length and breadth of the rectangle, whose area is given as : $25a^2 - 35a + 12$.
7. In the given figure, $AB = BC$ and $BX = BY$. Show that $AX = CY$. State the Euclid's axiom used. 2

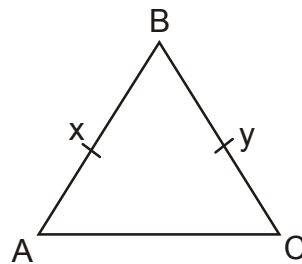

8. Two supplementary angles are in the ratio 2 : 3. Find the angles. 2
9. A point P (2, 3) lies in first quadrant. What will be the co-ordinates of a point Q opposite to it in fourth quadrant having equal distance from x-axis? 2
10. Find the area of a triangular field whose sides are 50 m, 65 m and 65 m. 2

SECTION – C

Question numbers 11 to 20 carry 3 marks each.

11. Write $\sqrt[3]{4}$, $\sqrt{3}$, $\sqrt[4]{6}$ in ascending order. 3
12. Simplify : $4\sqrt{2} - 2\sqrt{8} + \frac{3}{\sqrt{2}}$. 3
13. If $a + b + c = 5$ and $ab + bc + ca = 12$, find $a^2 + b^2 + c^2$. 3
14. Find the value of p for which the polynomial $x^3 + x^2 - 3x - p$ is exactly divisible by polynomial $x + 3$.
15. In the given figure, $\angle x > \angle y$, Show that $\angle LMN < \angle LNM$. 3

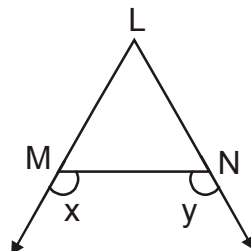

16. Prove that angles opposite to equal sides of an isosceles triangle are equal. 3

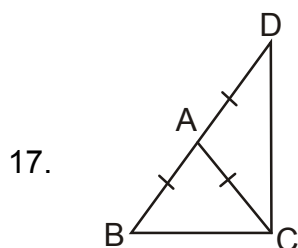

In the given figure, $\triangle ABC$ is an isosceles triangle in which $AB = AC$. Side BA is produced to D such that $AD = AC$. Show that $\angle BCD$ is a right angle. 3

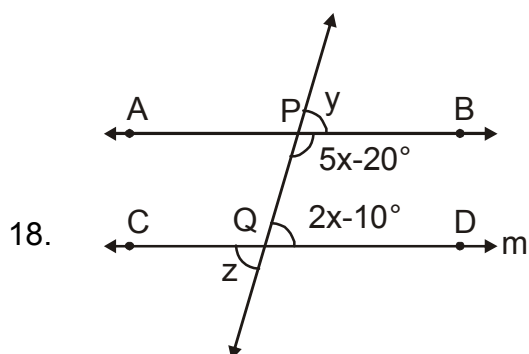

In the given figure, if $AB \parallel CD$, $\angle BPQ = (5x - 20^\circ)$ and $\angle PQD = (2x - 10^\circ)$, find the values of y and z . 3

19. In a four sided field $ABCD$, the length of the longer diagonal AC is 120m . The lengths of the perpendiculars from the opposite vertices upon this diagonal are 12.7 m and 7.3 m . Find the area of the field. 3

20. Plot the points $A(1, 0)$, $B(4, 0)$ and $D(1, 3)$ on the cartesian plane. Find the coordinates of the point C such that $ABCD$ is a square. 3

SECTION – D

Question numbers 21 to 31 carry 4 marks each.

21. Express $0.6 + 0.4\bar{7} + 0.\bar{7}$ in the form $\frac{p}{q}$, where p and q are integers and $q \neq 0$. 4

22. Prove that : $\left(\frac{x^a}{x^b}\right)^{\frac{1}{ab}} \cdot \left(\frac{x^b}{x^c}\right)^{\frac{1}{bc}} \cdot \left(\frac{x^c}{x^a}\right)^{\frac{1}{ca}} = 1$. 4

23. Factorise $4x^3 + 20x^2 + 33x + 18$, given that $2x + 3$ is a factor. 4

24. Simplify : $\frac{(a^2 - b^2)^3 + (b^2 - c^2)^3 + (c^2 - a^2)^3}{(a - b)^3 + (b - c)^3 + (c - a)^3}$ 4

25. Factorise : $(p + q)^2 - 20(p + q) - 125$. 4

26. If $x + \frac{1}{x} = 6$, find the value of $x^4 + \frac{1}{x^4}$. 4

27. In the given figure, $AB = AD$, $\angle 1 = \angle 2$ and $\angle 3 = \angle 4$. Prove that $AP = AQ$. 4

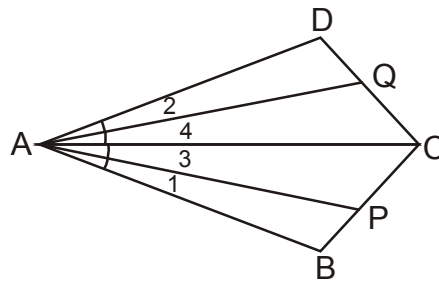

28. S is any point in the interior of a $\triangle PQR$. Prove that $SQ + SR < PQ + PR$. 4

29. In the figure $BL \perp AC$, $MC \perp LN$, $AL = CN$ and $BL = CM$. Prove that $\triangle ABC \cong \triangle NML$. 4

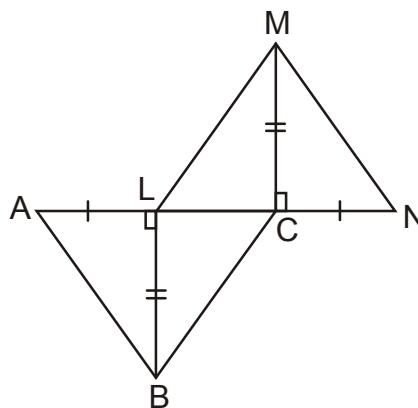

30. In the figure ADG represents a school gate followed by a ramp HJ, instead of stairs to make easy for physically challenged students to climb. HJ is equal to its hand rail BC and BC is equal to mid support EF. What is the relation between EF and HJ? State the Euclid's axiom used by you. Which value is the school exhibiting by placing ramp instead of stairs? State one more Euclid's axiom. 4

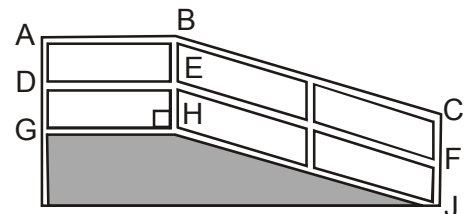

31. In the given figure, if two isosceles triangles ABC and DBC have a common base, prove that, the line segment joining their vertices is the perpendicular bisector of common base. 4

