

MATHEMATICS - 2019**D-191100 B****Maximum Marks : 75****Time : 3 hours****PART – A (Choose and write the correct option)**

- (i) How many tangents can be drawn on the circle from a point outside the circle ?
 (a) one and only one (b) two and only two
 (c) three and only three (d) none of these

Sol. (b) Two and only two

- (ii) The product of roots of quadratic equation $2x^2 - 4x + 3 = 0$ will be

- (a) $-\frac{3}{2}$ (b) $-\frac{1}{2}$ (c) $\frac{3}{2}$ (d) $-\frac{3}{4}$

Sol. (c) Given equation $2x^2 - 4x + 3 = 0$

$$\text{Product of roots} = \frac{c}{a} = \frac{3}{2}$$

- (iii) The zeroes of the polynomial $p(x) = x^2 - 3x - 4$ will be

- (a) 1 (b) -2 (c) 2 (d) -1

Sol. (d) Given polynomial $P(x) = x^2 - 3x - 4$

$$\Rightarrow P(x) = x^2 - 3x - 4$$

$$= x^2 - 4x + x - 4$$

$$= x(x - 4) + 1(x - 4)$$

$$= (x - 4)(x + 1)$$

$$\text{Zeroes} = -1, 4$$

- (iv) The value of $\tan(90^\circ - 45^\circ)$ will be

- (a) $\frac{1}{\sqrt{3}}$ (b) 1 (c) $\sqrt{3}$ (d) 0

Sol. (b) $\tan(90^\circ - 45^\circ) = \tan 45^\circ = 1$

- (v) The formula to find the maturity amount in fixed deposit is

(a) Total amount = Principal amount $\left(1 + \frac{\text{Rate}}{100}\right)^{\text{Time}}$

(b) Principal amount = Total amount $\left(1 + \frac{\text{Rate}}{100}\right)^{\text{Time}}$

(c) Total amount = Principal amount $\left(1 + \frac{\text{Time}}{100}\right)^{\text{Rate}}$

(d) Principal amount = Total amount $\left(1 + \frac{\text{Time}}{100}\right)^{\text{Rate}}$

Sol. (a) Total amount = (Principal amount) $\left(1 + \frac{\text{Rate}}{100}\right)^{\text{time}}$

PART – B (Match the following)

- | (A) | (B) |
|---|--------------------|
| (i) Slope of line in the straight line $5x + 6y = 7$ will be | (a) 12 |
| (ii) The ratio of the areas of two similar triangles is to the ratio of square of their corresponding sides | (b) 4 |
| (iii) The arithmetic mean of 16 and 8 will be | (c) 3 |
| (iv) The number of space diagonals of the cuboid is | (d) equal |
| (v) If $\theta = 60^\circ$, then the value of $\tan^2\theta$ will be | (e) $-\frac{5}{6}$ |

Sol. (i) (e) line $y = \frac{-5}{6}x + \frac{7}{6}$ slope $m = \frac{-5}{6}$

(ii) (d) Ratio of Area Similar triangles = Ratio of squares of corresponding sides

(iii) (a) A.M. = $\frac{16+8}{2} = \frac{24}{2} = 12$

(iv) (b) No. of space diagonals = 4

(v) (c) $\tan^2 60^\circ = (\sqrt{3})^2 = 3$

PART – C (Fill in the Blanks)

- (i) The combination of rational and irrational number is called _____ number.
- (ii) The third proportional of 18 and 6 will be _____.
- (iii) If the coordinate of any point is (0, 5) then the point will lie on the _____ axis.
- (iv) The tax which is levied on a person's income received from all sources is called _____.
- (v) Angle subtended by the diameter of a circle at a point on the circumference is _____.

- Sol.** (i) Real
 (ii) $18 : 6 :: 6 : x$
 $x = \frac{6 \times 6}{18} = 2$
 (iii) y = axis
 (iv) Income tax
 (v) Right angle (90°)

2. If $(x + 3) : 27 :: 1 : 3$, then find the value of x.

Sol. Given : $(x + 3) : 27 :: 1 : 3$
 $\Rightarrow (x + 3) \times 3 = 27 \times 1$
 $x + 3 = \frac{27 \times 1}{3}$
 $x + 3 = 9$
 $x = 6$

3. Find the median of the following data :

45, 41, 43, 38, 40, 42, 44

Sol. Given observations 45 , 41 , 43 , 38 , 40 , 42 , 44

Arranged data : 38 , 40 , 41 , 42 , 43 , 44 , 45

Total number of observations = n = 7

$$\text{Median} = \left(\frac{n+1}{2}\right)^{\text{th}} \text{ obs} = \left(\frac{7+1}{2}\right)^{\text{th}} = 4^{\text{th}} \text{ obs}$$

Median = 42.

4. Find the value of $\sin^2 15^\circ + \sin^2 75^\circ$.

Sol. $\sin^2 15^\circ + \sin^2 75^\circ \Rightarrow [\sin(90 - 75)]^2 + \sin^2 75^\circ$

$$\Rightarrow \cos^2 75^\circ + \sin^2 75^\circ \Rightarrow 1$$

5. A line passes through the points (8, 5) and (10, 6), then find the slope of the line.

Sol.

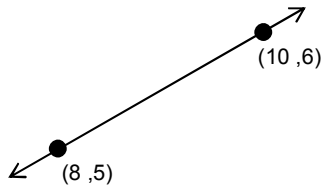

$$\text{Slope} = M = \frac{6-5}{10-8} = \frac{1}{2} \left(\frac{y_2 - y_1}{x_2 - x_1}\right)$$

6. Solve the quadratic equation : $x^2 - 9x = 0$.

Sol. Given equation $x^2 - 9x = 0$

$$\Rightarrow x(x - 9) = 0 \Rightarrow x = 0, x = 9$$

7. Prove that $6n + 13$ is an odd integer, where n is an integer.

Sol. To prove : $6n + 13$ is odd integer , $n \in I$.

Case I : When n is an odd integer $n = 2m + 1$

$$\Rightarrow 6n + 13 = 6(2m + 1) + 13 = 12m + 6 + 13$$

Which is odd.

Case II : When $n = \text{Even} = 2m$

$$6n + 13 = 6(2m) + 13 = 12m + 13$$

Which is again odd.

8. Find the value of k if $(x - 1)$ is a factor of the polynomial $P(x) = x^2 + kx + 2$.

Sol. Given polynomial $P(x) = x^2 + kx + 2$

given factor = $(x - 1)$

By remainder theorem $x - 1 = 0$

$$x = 1$$

remainder $P(1) = 0$

$$\Rightarrow (1)^2 + k(1) + 2 = 0$$

$$k + 3 = 0$$

$$k = -3$$

9. Find the nature of roots of the quadratic equation $4x^2 - x + 1 = 0$.

Sol. Given equation $4x^2 - x + 1 = 0$

for given equation $D = b^2 - 4ac$

$$D = (-1)^2 - 4(4)(1)$$

$$= 1 - 16 = -15$$

$$\therefore D < 0$$

\therefore roots are imaginary.

10. Find the total surface area of a hemisphere of diameter 10 cm.

Sol. **Given :** radius of hemisphere $r = \frac{10}{2} = 5$ cm

$$\text{Total surface area} = 3\pi r^2 = 3 \times \frac{22}{7} \times 5 \times 5 = 235.71 \text{ cm}^2$$

11. Prove that if we draw a line which is parallel to any one side of a triangle and intersects the other two sides at different points, then this line divides these two sides in the same ratio.

Sol.

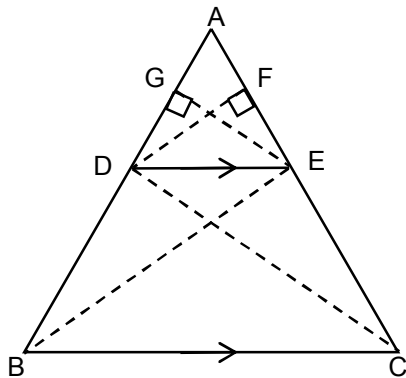

Given : In $\triangle ABC$, $DE \parallel BC$.

To prove : $\frac{AD}{DB} = \frac{AE}{EC}$

Construction : Draw $DF \perp AE$ and $EG \perp AD$ and join B to F and C to D.

Proof : In Area $\triangle ADE = \frac{1}{2} \times \text{Base} \times \text{Height}$

$$= \frac{1}{2} \times AD \times EG \quad \dots(1)$$

$$\text{Area } \triangle BDE = \frac{1}{2} \times BD \times EG \quad \dots(2)$$

$$\Rightarrow \frac{\text{Area} \triangle ADE}{\text{Area} \triangle BDE} = \frac{AD}{BD} \quad \dots(3)$$

$$\text{Now, Area } \triangle ADE = \frac{1}{2} \times AE \times DE \quad \dots(4)$$

$$\text{Area } \triangle DEC = \frac{1}{2} \times CE \times DE \quad \dots(5)$$

By eq. (4) \div eq.(5)

$$\frac{\text{Area} \triangle ADE}{\text{Area} \triangle DEC} = \frac{AE}{EC} \quad \dots(6)$$

$\therefore DE \parallel BC$

\therefore Area of $\triangle BDE = \text{Area } \triangle CDE$ { Triangles on the same base and between the same parallels}... (7)

By eq.(3), eq.(6) & eq.(7)

we can't say that $\frac{AD}{DB} = \frac{AE}{EC}$ hence proved

OR

If PAB is a secant to a circle which intersects the circle at A and B, and PT is a tangent to the circle, then prove that $PA \times PB = PT^2$.

Sol. **Given :** In a circle with centre O, PAB is a secant and PT be the tangent.

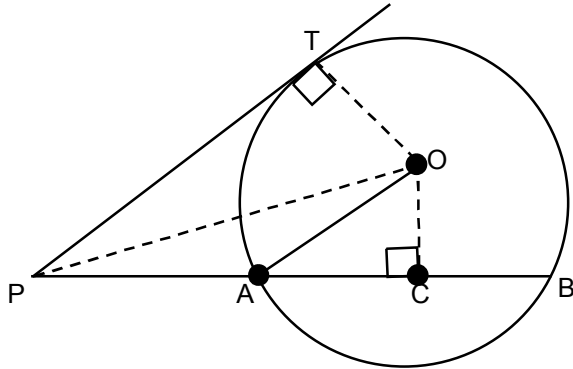

To Prove : $PA \times PB = PT^2$

Construction : Draw $OC \perp AB$. Join O to A and O to P and OT.

Proof : From figure $PA \times PB = (PC - AC)(PC + BC)$

$\because OC \perp AB$

$\therefore AC = BC$

$\Rightarrow PA \times PB = (PC - AC)(PC + AC)$

$= PC^2 - AC^2 \{ \because (a - b)(a + b) = a^2 - b^2 \}$

$= PC^2 - (OA^2 - OC^2) \{ PC^2 = OP^2 - OC^2 \}$

$= OP^2 - OC^2 - OA^2 + OC^2 \{ \because OA = OT \text{ (radius of circle)} \}$

$PA \times PB = OP^2 - OT^2$

$PA \times PB = PT^2$ hence proved

12. Find the relation between x and y such that point (x, y) is equidistant from the point (7, 1) and (3, 5).

Sol. **Given :** point P(x, y) is equidistant from A (7, 1) & B (3, 5)

$PA = PB$

By distance formular $PA = \sqrt{(x_1 - x_2)^2 + (y_1 - y_2)^2}$

$PA = \sqrt{(x - 7)^2 + (y - 1)^2} \dots (1)$

Similarly $PB = \sqrt{(x - 3)^2 + (y - 5)^2} \dots (2)$

from equation (1) & (2) $PA = PB$

$\sqrt{(x - 7)^2 + (y - 1)^2} = \sqrt{(x - 3)^2 + (y - 5)^2}$

squaring at both side

$\Rightarrow (x - 7)^2 + (y - 1)^2 = (x - 3)^2 + (y - 5)^2$

$\Rightarrow x^2 - 14x + 49 + y^2 - 2y + 1 = x^2 - 6x + 9 + y^2 - 10y + 25$

$\Rightarrow -14x - 2y + 50 = -6x - 10y + 34$

$\Rightarrow 8x - 8y - 16 = 0$

$\Rightarrow 8x - 8y = 16$

$x - y = 2$

OR

Find the value of x^2 for different values of x and draw a graph between x and x^2 . The values of x are integer numbers between -4 and $+4$.

Sol.

x	-3	-2	-1	0	1	2	3
x^2	9	4	1	0	1	4	9

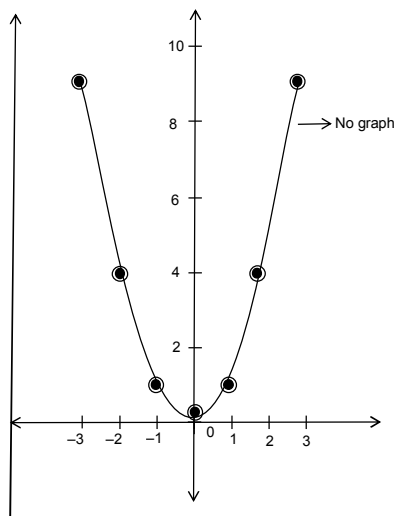

13. Data of weight of young and old groups of children (students) of a senior secondary school is given below. Find the mean of the data.

Weight in kg	30 – 40	40 – 50	50 – 60	60 – 70	70 – 80
Number of students	11	29	6	3	1

Sol.

Weight in kg	No. of students (f)	x_i	$f_i x_i$
30 – 40	11	35	385
40 – 50	29	45	1305
50 – 60	6	55	330
60 – 70	3	65	195
70 – 80	<u>1</u>	75	<u>75</u>
	50		2290

$$\text{Mean} = \frac{\sum f_i x_i}{\sum f_i} = \frac{2290}{50} = 45.8$$

OR

Wickets taken by many bowler in international one day cricket matches are given in the table. Find the mode of the data.

Nos. of Wickets	0 – 50	50 – 100	100 – 150	150 – 200	200 – 250	250 – 300
Nos. of Bowlers	4	5	16	12	3	2

Sol.

No. of wickets	No. of Bowlers
0 – 50	4
50 – 100	5
100 – 150	16
150 – 200	12
200 – 250	3
250 – 300	2

Modal class = 100 – 150 $\therefore l = 100$

$f_i = 16$, $f_0 = 5$, $f_2 = 12$

$$\text{Mode} = l + \frac{f_i - f_0}{2f_i - f_0 - f_2} \times h$$

--	--

$$= 100 + \frac{(16-5)}{(2 \times 16) - 5 - 12} \times 50$$

$$= 100 + \frac{11}{15} \times 50$$

$$= 136.67$$

- 14.** Area of curved surface of cylinder, whose height is 14 cm, is 88 square cm. Find the volume of the cylinder.

Sol. Given : Height of cylinder = 14 cm

$$\text{Curved surface area} = 88 \text{ cm}^2$$

$$\Rightarrow 2\pi rh = 88$$

$$2 \times \frac{22}{7} \times r \times 14 = 88$$

$$r = \frac{88 \times 7}{2 \times 22 \times 14} = 1 \text{ cm}$$

$$\text{Volume of cylinder} = \pi r^2 h = \frac{22}{7} \times 1 \times 1 \times 14 = 44 \text{ cm}^3$$

OR

If the curved surface area of a cone is 77π square cm and diameter of its base is 14 cm, then find the height of the cone.

Sol. Given : Curved surface area of cone = $77\pi \text{ cm}^2$

$$\text{diameter of cone} = 14 \text{ cm}$$

$$\text{radius} = 7 \text{ cm}$$

$$\text{C.S.A. of cone} = \pi rl = 77\pi$$

$$\pi \times 7 \times l = 77\pi$$

$$l = 11 \text{ cm}$$

$$\text{For cone } l = \sqrt{r^2 + h^2}$$

$$\Rightarrow 11^2 = (7)^2 + h^2$$

$$\Rightarrow h^2 = 121 - 49 = 72$$

$$h = 6\sqrt{2} \text{ cm}$$

- 15.** Construct a circumcircle of $\triangle ABC$, where $AB = 8 \text{ cm}$, $BC = 5 \text{ cm}$ and $\angle ABC = 60^\circ$. Write the steps of construction.

Sol. **Steps of Constructions :**

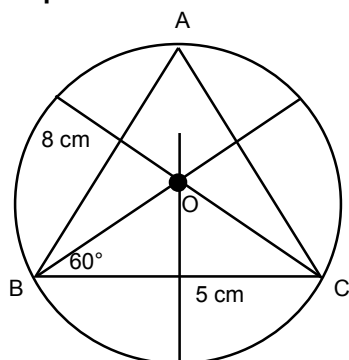

Step 1 : Draw $BC = 5 \text{ cm}$ at B draw an angle of 60° i.e., $\angle XBC = 60^\circ$.

Step 2 : Taking B as centre draw an arc of 8 cm at BX which is point A. join AC.

Step 3 : Draw the perpendicular bisectors of the line segments BC, AB and AC.

Step 4 : Point at which the three perpendiculars meet is the circumcenter of the circle. mark it as O.

Step 5 : From centre O, draw circle of radius OA, OC.

Step 6 : Circle passes through point A, B and C, therefore is the required circumcircle.

OR

Construct a ΔPQR in which $QR = 6$ cm, $PQ = 5$ and $\angle PQR = 60^\circ$. Also construct a ΔABC in which $AB = \frac{2}{5}PQ$.

Sol. Steps of Constructions :

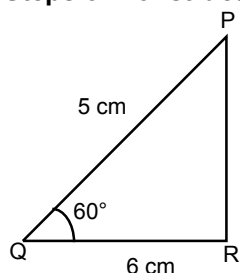

Step 1 : Draw $QR = 6$ cm at Q draw an angle of P of 60° .

Step 2 : Draw $\angle XPR = 60^\circ$ from Q draw an arc of 5 cm. which is point P. therefore ΔPQR is the required triangle.

Step 3 : From Q draw an acute angle $\angle RQY$.

Step 4 : From Q draw equal arc i.e., $QQ_1 = Q_1Q_2 = Q_2Q_3 = Q_3Q_4 = Q_4Q_5$.

Step 5 : Join Q_5 to R, draw line parallel to Q_5R from Q_2 . Which intersect QR at R' from R' . draw line parallel to PR . which intersect PQ at P'

Step 6 : $P'QR'$ is the required triangle ΔABC .

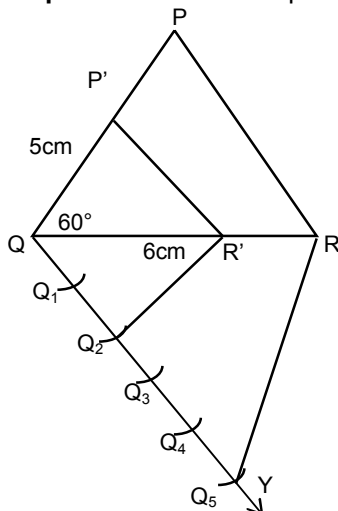

16. The income of a government employee in financial year 2013-2014 was Rs. 4,10,000. She deposited Rs. 24000 as yearly premium on life insurance policy, Rs. 4,000 every month in General Provident Fund and she also purchased a national savings certificate worth Rs. 25,000. If a maximum of Rs. one lakh can be invested in any type of saving to qualify for tax rebate, then calculate the payable tax.

The rates of tax are as follows :

S.No.	Tax Limits	Rate of Tax
1.	Up to Rs.2,00,000	Nil
2.	Rs. 2,00,001 to Rs. 5,00,000	10%
3.	Rs. 5,00,001 to Rs. 10,00,000	20%

In addition, a 3% education cess has to be paid over the income tax.

Sol. Gross income = 4,10,000
 saving (LIC + PF + NSE) = 97,000
 Taxable income = 3,13,000
 - 2,00,000
 1,13,000

$$\text{Tax} = 1,13,000 \times \frac{10}{100} = 11,300$$

$$\text{Educational cess @ 3\%} = 11,300 \times \frac{3}{100} = 339$$

$$\text{Total tax} = 11,639$$

OR

Padmani opened a recurring deposit account in district cooperative bank for 10 years and her monthly installment is Rs. 100. If on maturity she gets Rs. 3,025 as interest, then what is the rate of interest per annum ?

Sol.

$$\text{Interest} = 3025$$

$$\text{No. of months} = 10 \times 12 = 120$$

$$\text{Interest on recurring deposit} = \frac{\text{Monthly deposit} \times \text{Rate} \times \text{No. of month} (\text{No. of month} + 1)}{100 \times 24}$$

$$3025 = \frac{100 \times R \times 120 \times 121}{100 + 24}$$

$$3025 = 121 \times 5 \times R$$

$$3025 = 605 \times R$$

$$R = \frac{3025}{605} = 5\%$$

17. Solve the trigonometric equation : $\frac{\cos \theta}{\operatorname{cosec} \theta + 1} + \frac{\cos \theta}{\operatorname{cosec} \theta - 1} = 2$.

Sol. Given : $\frac{\cos \theta}{\operatorname{cosec} \theta + 1} + \frac{\cos \theta}{\operatorname{cosec} \theta - 1} = 2$

L.H.S. $\frac{\cos \theta}{\operatorname{cosec} \theta + 1} + \frac{\cos \theta}{\operatorname{cosec} \theta - 1} = 2$ [$\operatorname{cosec} \theta \neq 1$]

$$= \frac{\cos \theta (\operatorname{cosec} \theta - 1) + \cos \theta (\operatorname{cosec} \theta + 1)}{\operatorname{cosec}^2 \theta - 1} = 2$$

$$\Rightarrow \frac{\cos \theta \operatorname{cosec} \theta - \cos \theta + \cos \theta \operatorname{cosec} \theta + \cos \theta}{\cot^2 \theta} = 2 \quad [\because \operatorname{cosec}^2 \theta - 1 = \cot^2 \theta]$$

$$\Rightarrow 2 \cos \theta \operatorname{cosec} \theta = 2 \cot^2 \theta \quad \left[\because \operatorname{cosec} \theta = \frac{1}{\sin \theta} \right]$$

$$\Rightarrow \frac{\cos \theta}{\sin \theta} = \cot^2 \theta. \quad \Rightarrow \cot \theta - \cot^2 \theta = 0 \quad \Rightarrow \cot \theta [1 - \cot \theta] = 0$$

$$\cot \theta = 0$$

Reject as $\operatorname{cosec} \theta \neq 1$

$$1 - \cot \theta = 0$$

$$\cot \theta = 1$$

$$\theta = 45^\circ$$

OR

A straight road goes straight up till the base of the building. A man on the top of the building sees a car at 30° angle of depression. The car is moving towards the building at a uniform speed. After the car has covered a distance of 30 meters, the angle of depression becomes 60° . Then find the height of the building.

Sol.

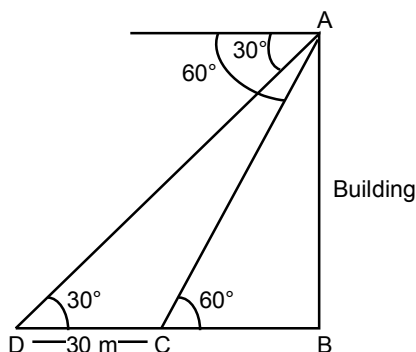

Let the height of the building

$$AB = h \text{ m}$$

$$\text{and } BC = x \text{ m}$$

then in $\triangle ABC$

$$\tan 60^\circ = \frac{AB}{BC}$$

$$\sqrt{3} = \frac{h}{x}$$

$$h = \sqrt{3}x \dots(1)$$

Now in $\triangle ABD$

$$\tan 30^\circ = \frac{AB}{BD}$$

$$\frac{1}{\sqrt{3}} = \frac{h}{30+x}$$

$$30+x = \sqrt{3} h \dots (2)$$

from equation (1) $h = \sqrt{3} x$ in equation (1)

$$30+x = \sqrt{3} (\sqrt{3}x)$$

$$30+x = 3x \quad \Rightarrow 2x = 30$$

$$x = 15 \text{ m}$$

$$\therefore h = 15\sqrt{3} \text{ m}$$

$$\text{height of building} = 15\sqrt{3} \text{ m}$$

- 18.** If p^{th} , q^{th} and r^{th} terms of an arithmetic progression are a , b , c respectively then prove that $a(q-r) + b(r-p) + c(p-q) = 0$.

Sol. Given : Let the first term of an A.P. = A
and the common difference = d

then $A_p = a$

$$A + (p-1)d = a \dots(1)$$

$$A + (q-1)d = b \dots(2)$$

$$A + (r-1)d = c \dots(3)$$

from equation (2) – Eq(3)

$$(q-r)d = (b-c)$$

$$(r-p)d = (c-a)$$

$$(p-q)d = (a-b)$$

$$\text{then } a(q-r) + b(r-p) + c(p-q) \Rightarrow \frac{a(b-c)}{d} + \frac{b(c-a)}{d} + \frac{c(a-b)}{d}$$

$$\Rightarrow \frac{1}{d} [ab - ac + bc - ab + ac - bc] \quad \Rightarrow 0 \text{ hence proved}$$

OR

Seven times of a two – digit number is equal to 4 times of the number formed by reversing the digits.

The sum of the two digits is 3. Find the number.

Sol. Let the two digit number be = $10x + y$

$$\text{then } 7(10x + y) = 4(10y + x)$$

$$70x + 7y = 40y + 4x$$

$$66x - 33y = 0$$

$$2x - y = 0 \dots(1)$$

$$\text{then } x + y = 3 \dots(2)$$

from equation (1) put $y = 2x$ in equation (2)

$$x + 2x = 3$$

$$3x = 3$$

$$x = 1$$

$$\therefore y = 2$$

$$\therefore \text{number} = 12.$$
