

# **JOB ROLE: FIELD TECHNICIAN – OTHER HOME APPLIANCES**

(QUALIFICATION PACK: Ref. Id. ELE/Q3104)

**STUDENT TEXTBOOK**

**CLASS 9**

**Sector: ELECTRONICS**

**PSS CENTRAL INSTITUTE OF VOCATIONAL EDUCATION**

(a constituent unit of NCERT, under MHRD, Government of India)

Shyamla Hills, Bhopal- 462 002, M.P., India

**<http://www.psscive.ac.in>**

## FOREWORD

The National Curriculum Framework–2005 (NCF–2005) recommends bringing work and education into the domain of the curricular, infusing it in all areas of learning while giving it an identity of its own at relevant stages. It explains that work transforms knowledge into experience and generates important personal and social values such as self-reliance, creativity and cooperation. Through work one learns to find one's place in the society. It is an educational activity with an inherent potential for inclusion. Therefore, an experience of involvement in productive work in an educational setting will make one appreciate the worth of social life and what is valued and appreciated in society. Work involves interaction with material or other people (mostly both), thus creating a deeper comprehension and increased practical knowledge of natural substances and social relationships.

Through work and education, school knowledge can be easily linked to learners' life outside the school. This also makes a departure from the legacy of bookish learning and bridges the gap between the school, home, community and the workplace. The NCF–2005 also emphasises on Vocational Education and Training (VET) for all those children who wish to acquire additional skills and/or seek livelihood through vocational education after either discontinuing or completing their school education. VET is expected to provide a 'preferred and dignified' choice rather than a terminal or 'last-resort' option.

As a follow-up of this, NCERT has attempted to infuse work across the subject areas and also contributed in the development of the National Skill Qualification Framework (NSQF) for the country, which was notified on 27 December 2013. It is a quality assurance framework that organises all qualifications according to levels of knowledge, skills and attitude. These levels, graded from one to ten, are defined in terms of learning outcomes, which the learner must possess regardless of whether they are obtained through formal, non-formal or informal learning. The NSQF sets common principles and guidelines for a nationally recognised qualification system covering Schools, Vocational Education and Training Institutions, Technical Education Institutions, Colleges and Universities.

It is under this backdrop that Pandit Sunderlal Sharma Central Institute of Vocational Education (PSSCIVE), Bhopal, a constituent of NCERT has developed learning outcomes based modular curricula for the vocational subjects from Classes IX to XII. This has been developed under the Centrally Sponsored Scheme of Vocationalisation of Secondary and Higher Secondary Education of the Ministry of Human Resource Development.

This textbook has been developed as per the learning outcomes based curriculum, keeping in view the National Occupational Standards (NOS) for the job role and to promote experiential learning related to the vocation. This will enable the students to acquire necessary skills, knowledge and attitude.

I acknowledge the contribution of the development team, reviewers and all the institutions and organisations, which have supported in the development of this textbook.

NCERT would welcome suggestions from students, teachers and parents, which would help us to further improve the quality of the material in subsequent editions.

HRUSHIKESH S ENAPATY

Director

National Council of Educational

Research and Training

New Delhi

June 2018

## **ACKNOWLEDGEMENT**

The National Council of Educational Research and Training (NCERT) expresses its gratitude to all members of the Project Approval Board (PAB) and officials of the Ministry of Human Resource Development (MHRD), Government of India, for their cooperation in the development of this textbook. The Council also extends gratitude to all the contributors for sharing expertise and valuable time by positively responding to the request for the development of this textbook.

The Council also acknowledges the contribution of the Review Committee member — Mamur Ali, Assistant Professor, CIET, NCERT, New Delhi, for carefully evaluating and giving suggestions for the improvement of this book.

The Council would also like to thank Rajesh Khambayat, Joint Director, PSS Central Institute of Vocational Education (PSSCIVE), Bhopal for providing support and guidance in the development of this textbook.

We are thankful to the course coordinator Dipak D. Shudhalwar, Associate Professor and Head, Department of Engineering and Technology, PSSCIVE, NCERT, Bhopal for developing the content for this textbook and also providing photographs used in the textbook.

Ganesh Kumar Dixit and Jayant Mishra, Consultants in IT-ITeS, Department of Engineering and Technology, PSSCIVE, Bhopal, are also duly acknowledged for their untiring efforts and contribution in the development of this textbook for vocational skills. The Council is grateful to Saroj Yadav, Professor and Dean (A), NCERT, and Ranjana Arora, Professor and Head, Department of Curriculum Studies, for their sincere efforts in coordinating the review workshops for the finalisation of this book. The Council acknowledges the copy editing and valuable contribution of Shilpa Mohan, Assistant Editor (Contractual) and Sanjeev Kumar, Copy Holder in shaping this book. The efforts of DTP Operators Pawan Kumar Barriar, Haridarshan Lodhi, DTP Operator (Contractual), Publication Division, NCERT, for flawless layout design are also acknowledged.

The Council is grateful to the Ministry of Human Resource Development for the financial support and cooperation in realising the objective of providing a quality textbook for the Indian vocational students.

Dipak D. Shudhalwar

Associate Professor (CSE)

Head, Department of Engineering and Technology

PSS Central Institute of Vocational Education

Bhopal

Jan, 2019



# **TEXTBOOK DEVELOPMENT COMMITTEE**

**CHAIRMAN, ADVISORY GROUP FOR TEXTBOOK**

**CHIEF ADVISER**

**MEMBERS**

Parag Shrivastava

Dipak D. Shudhalwar

**MEMBER-COORDINATOR**

Dipak D. Shudhalwar

**REVIEWERS**

CHAPTER 1. BASICS OF ELECTRICAL AND ELECTRONICS  
CHAPTER 2. ELECTRICAL AND ELECTRONIC COMPONENTS  
CHAPTER 3. TOOLS AND EQUIPMENT  
CHAPTER 4. INSTALLING AN RO WATER PURIFIER  
CHAPTER 5. REPAIR AND MAINTENANCE OF WATER PURIFIER  
CHAPTER 6. MAINTAIN HEALTH AND SAFETY

# BASICS OF ELECTRICAL AND ELECTRONICS

## 1.0 INTRODUCTION

Electricity has an important place in modern society. In this age, we have almost all the appliances that work on electricity. Even the automobile industry has started an electric car which will run on electricity instead of fuel. When power supply in a city breaks down, hospitals, hostels, office buildings, schools, food storage plants, banks and shops etc. will stop working. In this chapter we will focus on current electricity that powers our electronic and electrical gadgets.

Electricity makes no sound, does not have an odour, and cannot be seen. Learning the theory of electricity make us cautious about hazards associated with all electrical appliances. So it is very important to understand the concept of electricity for installation and troubleshooting electrical appliances.

The electric elements include controlled and uncontrolled source of energy, resistors, capacitors, inductors, etc. The electric circuit should be designed in the correct way to perform a specific function. Analysis of electric circuits refers to computations required to determine the unknown quantities such as voltage, current and power associated with one or more elements in the circuit. To work in the area of electrical engineering, the person should have the basic knowledge of electric circuit analysis and laws. Many other systems, like mechanical, hydraulic, thermal, magnetic and power system are easy to analyse and model by a circuit. To learn how to analyse the models of these systems, first one needs to learn the techniques of circuit analysis. We shall discuss briefly some of the basic circuit elements and the laws that will help us to develop the background of subject. In this chapter, students will understand the basic concepts of electricity and electrical circuits. Students can apply their knowledge to design, build, and demonstrate their own circuits



**Fig.1.1: Natural lightening**

## 1.1 ELECTRICITY

Electricity is the set of physical phenomena associated with the presence and flow of electric charge. Electricity gives a wide variety of well-known effects, such as lightning, static electricity, electromagnetic induction and electrical current. In addition, electricity permits the creation and reception of

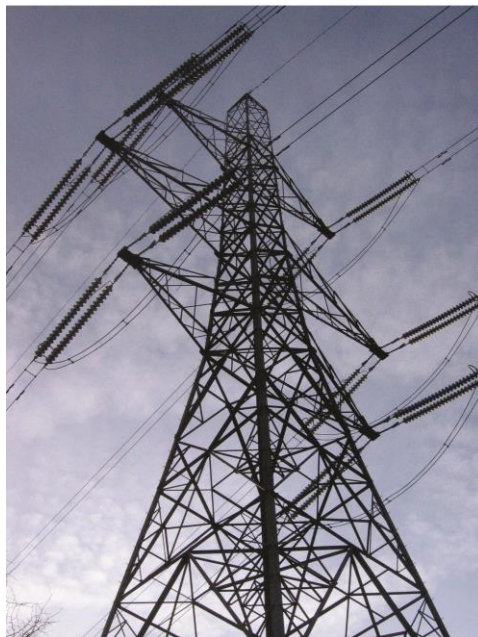
electromagnetic radiation such as radio waves. Electrical energy can be easily transferred from one location to another with minimum loss.

### **1.1.1 Source of Electricity**

Energy is the driving force for the universe. Energy is a quantitative property of a system. Natural electricity is generated by thunder storm and lightning as shown in *figure 1.2*.



**Fig.1.2: Natural discharging of charge, Courtesy: <https://goo.gl/em8G1g>**



**Fig.1.3: Transmission tower, Courtesy: <https://goo.gl/f6kGNx>**

### 1.1.2 Energy Transformation

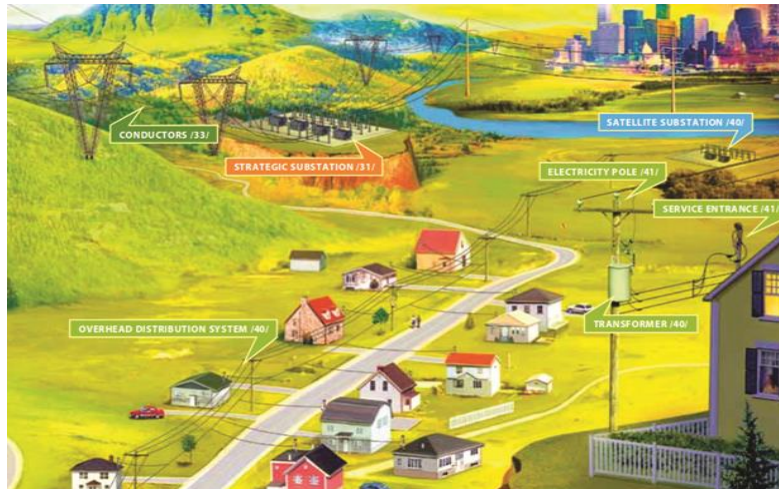
There are many different forms of energy, such as *thermal energy*, *hydel energy*, *solar energy*, *wind energy*, *nuclear energy*, etc. According to law of conservation of energy, the energy can neither be created nor destroyed it can only change its form. One form of energy can be transferred to another form. Electrical energy can be generated by transforming several types of energies.

Nuclear → Electrical  
Chemical → Electrical  
Hydel → Electrical  
Thermal → Electrical  
Solar → Electrical  
Wind → Electrical

For example, *figure 1.4(a) and 1.4(b)* shows how electrical energy can be generated from hydel energy in hydel power plant.



**Fig.1.4 (a) and Fig.1.4 (b): Generation and transmission of electricity, Courtesy: <https://goo.gl/Q5REKP>**

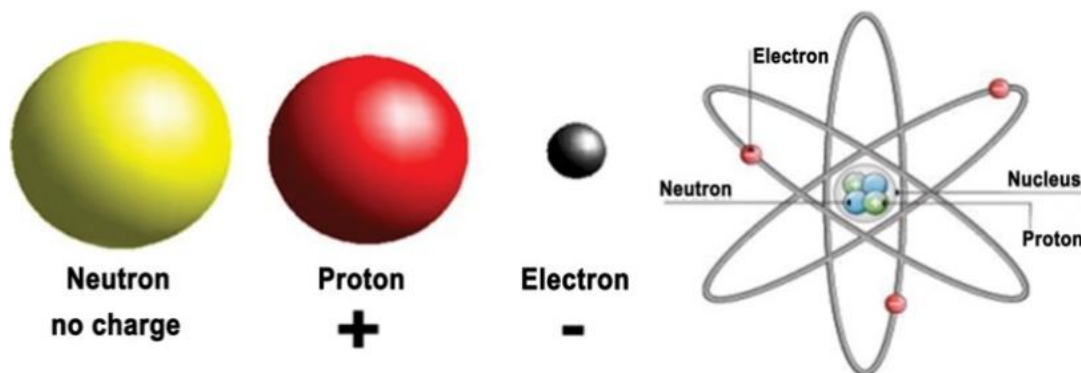


**Fig. 1.5: Distribution of electricity, Courtesy: <https://goo.gl/DtoSYN>**

### 1.1.3 Energy Foundation

To understand electricity, we need to know something about atoms. Everything in the universe solid, liquid, gases are made up of atoms. Every star, every tree, every animal and even the human body are made of atoms. Atoms are the building blocks of the universe. Atoms are so small that millions of them would fit on the head of a pin.

**Atoms:** The centre of an atom is called the nucleus. Atoms consist of sub atomic particles – *protons, electrons and neutrons*. The protons and neutrons are very small, and electrons are much, much smaller. Protons carries positive (+) charge, electrons carries negative (-) charge, neutrons are neutral. The positive charge of the protons is equal to the negative charge of the electrons. Electrons move in its orbit around the nucleus. The positively charge protons attract negatively charge electrons and hence holding the atomic structure as shown in *figure 1.6*.



**Fig.1.6: Atomic structure, Courtesy: <https://goo.gl/hP7FhD>**

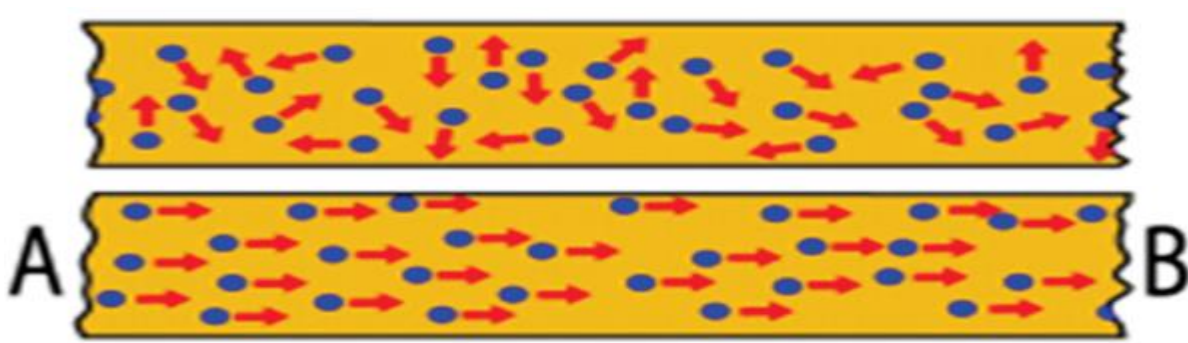


**Charge:** Electric charge is a basic property of *electrons, protons* and other subatomic particles. Opposite charges attract each other and same charges repel each other. This makes electrons and protons stick together to form atoms. One foundational unit of electrical measurement is *coulomb*, which is a measure of electric charge proportional to the number of electrons in an imbalanced state. It was discovered by *Charles-Augustine de Coulomb*.

One *coulomb* of charge is equal to the charge on  $6 \times 10^{18}$  (6,250,000,000,000,000,000) electrons. The symbol for electric charge quantity is the capital letter "Q," while the symbol of coulomb is represented by the capital letter "C."

### **Flow of charge inside a wire**

Inside conductor free electrons randomly moves from one point to another. Due to this random flow net electric charge of a conductor is zero. When an external power source is attached, net flow of electrons is in one direction. This movement of electrons results in a current. If there is a current of 1 ampere passing through a wire it theoretically means that  $6 \times 10^{18}$  electrons are moving from one point to another in 1 second as shown in *figure 1.7*.



**Fig.1.7: Flow of charges**

### **1.1.4 Conductors and Insulators**

When electrons move among the atoms of matter, a current of electricity is created. As in case of piece of wire, the electrons are passed from atom to atom, creating an electrical current from one end to another.

**Conductors:** The material in which the electrons are loosely held, can move very easily. These are called conductors. The metals like copper, aluminium or steel are good conductors of electricity.

**Insulators:** The materials which hold their electrons very tightly, do not allow to move the electrons through them very well. These are called insulators. Rubber, plastic, cloth, glass and dry air are good insulators and have very high resistance.

### 1.1.5 Type of Electricity

As we have seen that electricity is a natural phenomenon. Naturally electricity is generated through lightning. This electricity is static in nature. Electricity can be generated in power plants. It is dynamic in nature. Thus electricity can be classified as:

1. Static electricity
  2. Dynamic or Current electricity
1. **Static electricity:** Materials are made of atoms. Atoms are electrically neutral because they contain equal numbers of positive and negative charges. Static electricity requires a separation of positive and negative charges. When electrons do not move from one point to another point electricity is called static electricity. Energy stored in electric cell or battery is an example of static electricity.
  2. **Dynamic or Current electricity:** Current electricity flows through wires or other conductors and transmits energy to devices. Flow of electricity is only possible because flow of charged particles like electrons. When electrons are in motion, electricity is called as dynamic or current electricity. Dynamic electricity cannot be stored. To store it has to be converted to static electricity. Current flowing through electrical wire and electrical AC appliances are the examples of dynamic electricity.

### Assignment

- Discuss the source of electricity. Discuss about renewable and non-renewable source of electricity.
- Prepare a data sheet in which electricity generating capacity of the five hydel power generating station are mentioned.
- List out the names of top five thermal power plants in India as per their electricity generating capacity.

### 1.2 ELECTRICAL QUANTITIES

*Current, voltage, and resistance* are the three basic building blocks of electric and electronic circuit. These are called as electrical quantities. You cannot see it with the naked eye the energy flowing through a wire or the voltage of a battery.

An electric circuit is formed when a conductive path is created to allow free electrons to move continuously. This continuous movement of free electrons through the conductors of a circuit is called a **current**, and it is often referred to in terms of "*flow*," just like the flow of a liquid through a hollow pipe.

The force motivating electrons to "*flow*" in a circuit is called **voltage**. *Voltage* is a specific measure of potential energy that is relative between two points.



Free electrons tend to move through conductors with some degree of friction, or opposition to motion. This opposition to motion is called **resistance**. The amount of current in a circuit depends on the amount of voltage available to motivate the electrons, and also the amount of resistance in the circuit to oppose electron flow.

The standard units of measurement for electrical *current, voltage, and resistance* are given below:

| Quantity   | Symbol | Unit of Measurement |
|------------|--------|---------------------|
| Current    | I      | ampere (A)          |
| Voltage    | V      | volt (V)            |
| Resistance | R      | ohm ( $\Omega$ )    |

The "symbol" given for each quantity is the standard alphabetical letter used to represent that quantity in an algebraic equation. Each unit of measurement is named after a famous experimenter in electricity: The amp after the **Frenchman Andre M. Ampere**, the volt after the **Italian Alessandro Volta**, and the ohm after the **German Georg Simon Ohm**.

### 1.2.1 Voltage

Voltage is the potential difference between two points. Voltage is also the amount of work required to move one coulomb charge from one point to another point. Mathematically it can be written as,

$$V=W/Q$$

where,

'V' is the voltage,

'W' is the work in joule,

'Q' is the charge in coulomb.



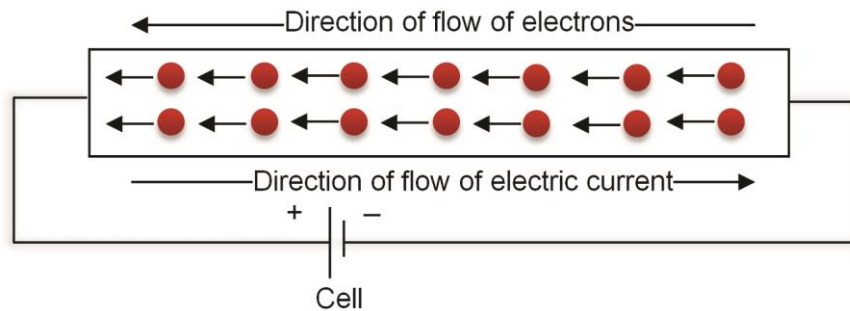
Alessandro Volta (1745–1827)

In an electric circuit the battery is used as an electric potential. Battery is one of the sources of voltage in electric circuit. Inside a battery, chemical reactions provide the energy needed to flow electrons from negative to positive terminal.

When voltage is applied in electric circuit, negatively charged particles are pulled towards higher voltages, while positively charged particles are pulled towards lower voltages. Therefore, the current in a wire or resistor always flows from higher voltage to lower voltage.

A voltmeter can be used to measure the voltage (or potential difference) between two points in a system. Value of voltage is measured in *volt* or *joules per coulomb*. Symbolic representation of voltage is '**V**' or '**v**'.

**Example:** When one joule of work is done to move one coulomb charge from one point to other point the potential difference between two points is said to be one volt.



**Fig.1.8: Flow of electrons on application of DC supply, Courtesy: <https://goo.gl/MtLkLK>**



**Fig.1.9 Diesel AC voltage generator, Courtesy: <http://bit.ly/2OCXheq>**



**Fig.1.10 DC voltage source in truck, Courtesy: <http://bit.ly/2MfJgSh>**

## 1.2.2 Current

The flow of electric charge is called electric current. The electrons carry charge. The electrons flow from one place to another. The number of moving electrons generates more charge. The amount of current flowing from one place to another is determined the amount of charge flowing through it per unit time as shown in

figure 1.11. Unit of current is ampere (A). Symbolic representation of current is 'I'. Mathematically it can be written as,

$$I = Q/t$$

Where,

'I' is the current,

'Q' is the amount of charge in coulombs

't' is the time in seconds

**Note:** Coulombs is the unit of charge.



André-Marie Ampère (1775–1836)

**Example:** If 1 coulomb charge passes through a point in 1 second, it will represent the 1 ampere current. Conventionally, the direction of current is taken as opposite to the flow of electrons.

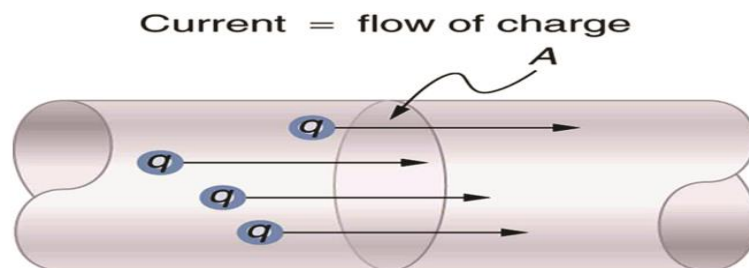


Fig. 1.11: Flow of charge through a cross section 'A', Courtesy: <https://goo.gl/SHj3PF>

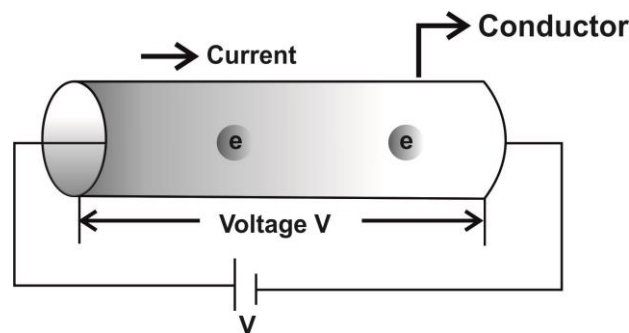


Fig.1.12 Flow of electrons in the conductor, Courtesy: <http://bit.ly/2vyfoth>

### Classification of current

Depending upon the movement of electrons in an electric circuit, current can be classified as:

1. Direct current (DC)
2. Alternating current (AC)

## Direct Current

Direct current is unidirectional in nature that is movement of electrons takes place only in one direction. This means that current flow only in one direction. DC voltage source (like batteries and cells) produces direct current. Direct current is used in wall clock, remote control, vehicles, automobile, cell phone etc.

## Alternating Current

Alternating current is bidirectional in nature that is movement of electrons takes place in two directions. This means that current flow in two directions. AC voltage source (like AC generator) produces alternating current. Hydel power plants, thermal power plants etc. are the examples of alternating voltage sources. Alternating current is used in ceiling fan, cooler, washing machine etc. In India, standard AC generating *frequency (f)* of alternating current is 50 hertz.

Frequency can be defines as “the number of cycles in one second”. From point A to point B represents one cycle. Hertz (Hz) is the unit of frequency.

Example: 50 Hz represents 50 cycles in 1 second.

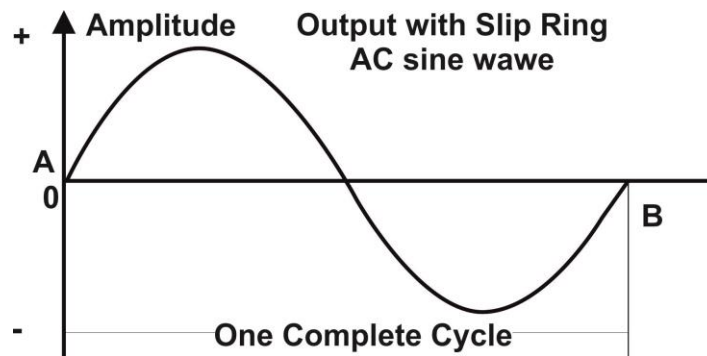


Fig. 1.13: Cycle of AC signal

The main difference between in AC and DC current is the directionality in the flow of electrons. In alternating current (AC, also ac), the movement of electric charge periodically reverses direction. In direct current (DC, also dc), the flow of electric charge is only in one direction.

The usual waveform of an AC power circuit is a sine wave. In certain applications, different waveforms are used, such as triangular or square waves. Audio and radio signals carried on electrical wires are also examples of alternating current.

### 1.2.3 Resistance

We know that in conductor's materials, electrons are loosely held and can move very easily. In insulators, electrons are tightly bound to their atoms and they do not move very easily. A very high voltage is required to move the electrons in an insulating material. On the other hand very small voltage is required to move the electrons in any conductor. In conductors the resistance is low, while in insulators the resistance is high.

Resistance resists the flow of electron and hence electric current in the circuit. Conceptually the resistance controls the flow of electric current. The resistance is represented by the symbol "R". The SI unit of electrical resistance is the ohm ( $\Omega$ ).

### 1.2.4 Electric Power

Electric power is the rate at which electric energy is transferred by an electric circuit. Electric power, is the rate of doing work, means "amount of work done in one second". The power is represented by symbol P. The SI unit of power is the **watt** (W). Unit of power is watt (W), which is equal to one joule per second. It is named in honour of Scottish inventor James Watt (1736 - 1819).

Electric horsepower (*hp*) is another unit of measurement of power. It is equal to 746 watts. It measures to be slightly higher than mechanical horsepower, which is 745.7 joules per second.

The electric power in watts produced by an electric current *I* consisting of a charge of *Q* coulombs every *t* seconds passing through an electric potential (voltage) difference of *V* is

$$P = \text{Work done per unit time} = QV/t = V \times I$$

Where, *Q* is electric charge in coulombs

*t* is time in seconds

*I* is electric current in amperes

*V* is electric potential or voltage in volts

$$P=W/t \text{ or } P=I^2R$$

Where,

'W' is the work done in joules

't' is the time in seconds

Power can also be defined in terms of current and voltage i.e. product of voltage and current results in power. Watt is a measure of energy flow. Since watt, is a very small unit of power, in actual practice we need a much larger unit, the kilowatt, which is equal to 1000 watts. Since, product of power and time gives electrical energy; therefore unit of electrical energy is watt hour or kilowatt hour. One watt hour of energy is consumed when 1 watt of power is used for 1 hour. The commercial unit of electric energy is kilowatt hour (kWh).



Georg Simon Ohm (1789 - 1854)



James Watt (1736 - 1819)



Fig.1.14: Domestic Efficiency Lighting Programme (DELP) 9 Watt LED

Courtesy: <http://bit.ly/2OGPqwj>

$$1\text{kWh} = 1000 \text{ watt} \times 3600 \text{ second}$$
$$= 3.6 \times 10^6 \text{ watt second or } 3.6 \times 10^6 \text{ joule}$$

For example, the power of this LED is 9 watt. This 9 watt defines it will do 9 joules of work in

1 second. LEDs are more efficient than CFL.

More to know: Government of India has launched National Programme for LED-based Home and Street Lighting in New Delhi for energy conservation by reducing energy consumption. Along with this programme, Government of India launched scheme for Light Emitting Diode (LED) bulb distribution under the Domestic Efficient Lighting Programme (DELP).



Fig.1.15

**Assignment:** A 100 watt electric bulb is lighted for 2 hours daily, and four 40 watts bulbs are lighted for 4 hours daily. Calculate the energy consumed (in kWh) in 30 days.

### 1.2.5 Power Factor

In AC circuit, various components are connected as resistor, inductor, and capacitor. These components consume power. When voltage is applied to an inductor it opposes the change in current. The current built up more slowly than the voltage, lagging in time and phase. In this way it can be stated that current lags the voltage. In case of capacitor, voltage is directly proportional to charge on it, current must lead the voltage in time and phase to conduct charge on the plates and raise the voltage. When inductor or capacitor is involved in an AC circuit, the current and voltage do not peak at same time. The fraction of a period difference between the peaks are expressed in degrees is said to be *phase difference*. The phase difference is  $\leq 90$  degrees. Because of this phase difference in voltage and current, power in capacitor and inductor

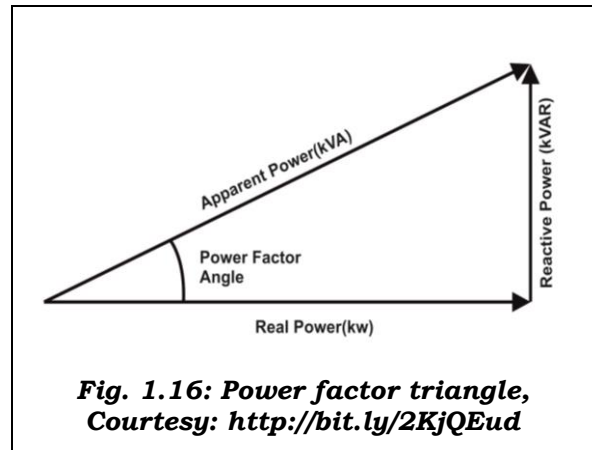


will be minimum, in other words it can be said that this power will get lost by the circuit. This power is called as *reactive power*. In case of resistor both current and voltage are in phase. Therefore, power applied to the resistor will

get utilized. This power is called as *real power or true power*. Combination of true power and reactive power is *apparent power*.

Power factor is the ratio of real power to the apparent power. Value of power factor varies from 0 to 1. It is denoted by  $\cos \phi$ .

Power factor = Real power / Apparent power

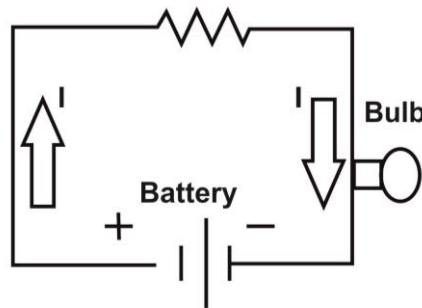


Referring to the *figure 1.16* it is observed that as the reactive power starts reducing the real power and apparent power become equal. When real power and apparent power become equal this means that AC circuit is resistive in nature i.e. it will only have a resistive component in the circuit. At this time, it can be summarized that reactive power due to

**Practical Activity: Form an electric circuit** as shown in *figure 1.17* and find out the parameter show voltage, current, resistance, power.

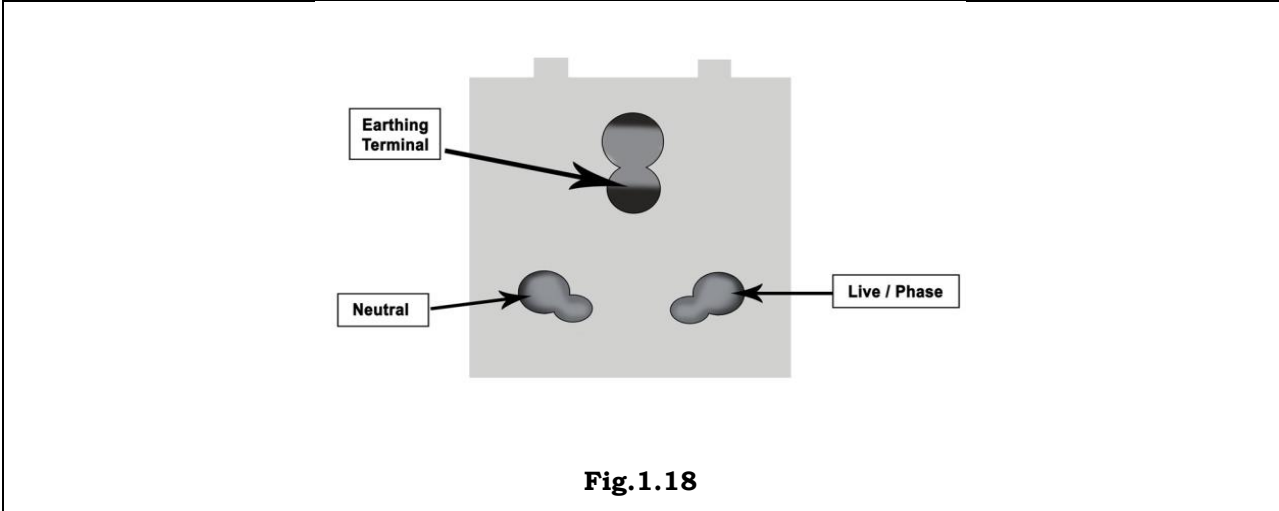
**Material Required:**

Battery of 9V, Fixed resistor of 3 Ohm, Bulb or LED of 5 watt.



**Fig.1.17**

**Practical Activity:** Identify Live, Neutral and Earth on the power socket shown in *figure 1.18*.

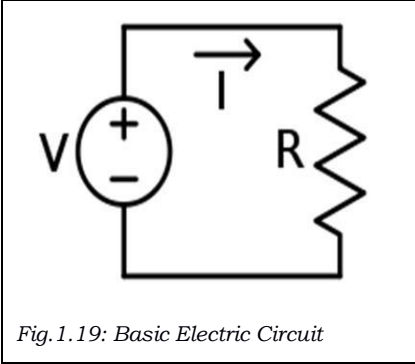


capacitor and inductor will not get utilized by circuit.

Apparent power is the total power given to the circuit, reactive power is the unutilized power, and real power is utilized power by the circuit.

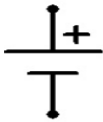
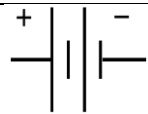
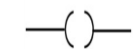
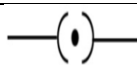

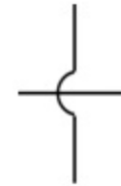



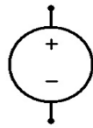
**1.3 BASIC ELECTRIC CIRCUIT**

The electrical circuit supply electricity to the electrical device. These devices are called loads. Before the load will operate, electricity must have a complete path from the source to the load and back to the source. This path for electricity is called a circuit. An electric circuit is an interconnection of electric components such that electric charge is made to flow along a closed path (a circuit), usually to perform some useful task. In the *figure 1.19*, the voltage source  $V$  on the left drives a current  $I$  around the circuit, delivering electrical energy into the resistor  $R$ . From the resistor, the current returns to the source, completing the circuit. The components in an electric circuit can include elements such as resistors, capacitors, switches, transformers and electronics. The components in the circuit can be active or passive.


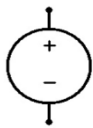
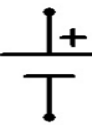
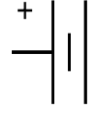
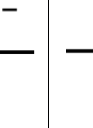
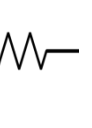




Symbols of some commonly used components in circuit diagrams are as follows:

| S.No. | Components                          | Symbol  |
|-------|-------------------------------------|---|
| 1     | An electric cell                    |    |
| 2     | A battery or a combination of cells |    |
| 3     | Plug key or switch (open)           |    |
| 4     | Plug key or switch (closed)         |    |
| 5     | A wire joint                        |    |
| 6     | Wires crossing without joining      |   |
| 7     | Electric bulb                       |   |
| 8     | A resistor of resistance R          |  |
| 9     | Variable resistance or rheostat or  |  |
| 10    | Ammeter                             |  |
| 11    | Voltmeter                           |  |

**Practical Activity:** Identify the following symbols

|   |   |   |   |   |   |          |   |   |
|---|---|---|---|---|---|----------|---|---|
|  |  |  |  |  |  | $\Omega$ | V | I |
|   |   |   |   |   |   |          |   |   |

### 1.3.1 Active and Passive components

There are two classes of electronic components – Active and Passive. Both these *electronic components* are different from each other.

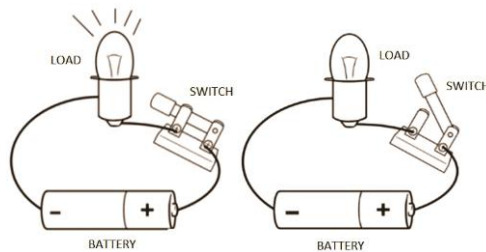
**Active components:** Active components produce energy in the form of Voltage or Current. These components required external source for their operation. Some of the common examples of active components are: Diode, Transistors, etc. If we connect a diode in a circuit and then connect this circuit to the supply voltage, then diode will not conduct the current until the supply voltage reach to 0.3V (in case of germanium) or 0.7V (in case of silicon).

**Passive components:** Passive components do not produce energy in the form of Voltage or Current. These components do not require external source for their operation. Some of the common examples of passive components are: Resistor, Capacitor, Inductor etc.

Like a Diode, Resistor does not require 0.3V or 0.7V. i.e., when we connect a resistor to the supply voltage, it starts work automatically without using a specific voltage. In simple words, active components are energy donor, and Passive components are energy acceptor

### 1.3.2 Open and Closed Circuit

A circuit is a closed path or loop around which an electric current flows. If the circuit is complete, it is called *Closed* and the device will receive power and work. If this path is broken, the circuit is *Open* and the device will not work as shown in *figure 1.20 (a)*, *figure 1.20 (b)*.

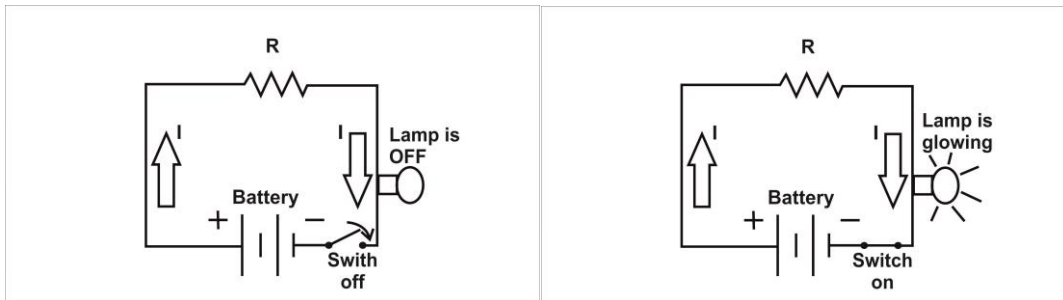


**Fig.1.20 (a): Closed circuit Fig.1.20 (b): Open circuit**

**Practical Activity: Analysis of open and close circuit**

Prepare the circuit to glow the lamp as shown in *figure 1.21 and 1.22*.

**Apparatus required:** 9 volts battery, connecting wire, resistor, lamp, wire stripper, wire cutter, and switch.



**Fig1.21** Open circuit

**Fig.1.22:** Close circuit

**Procedure:** Following steps are used to form a circuit:

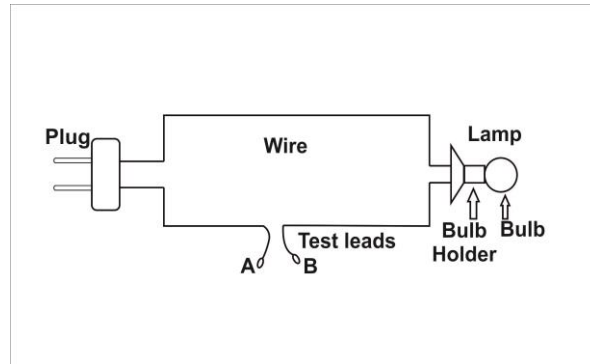
1. Take a battery; identify the positive and negative terminals of the battery.
2. Cut the wire using wire cutter and strip the insulation using wire stripper.
3. Connect the wire to the positive and negative terminal of the battery.
4. Connect the resistor to the wire which is connected to the positive terminal of battery.
5. Connect the other terminal of resistor to one of the terminal of lamp.
6. Connect the other terminal of the lamp to one of the terminal of switch.
7. Connect the other terminal of switch to the wire which is connected to the negative terminal of the battery.

**Result:** When the switch is turned 'ON' lamp start glowing.

**Practical Activity:** Construct a test lamp and use it to mains.

**Apparatus required:** 1 bulb, 1 bulb holder, wire, wire cutter, wire stripper, plug

### Circuit diagram:



*Fig.1.23: Circuit diagram for test lamp*

### Procedure:

1. Cut the wire into two pieces using wire cutter, making each one a meter long.
2. Now, you have two pieces of wire. Strip the insulation of the wire terminals.
3. Fix the bulb holder using one end of the two pieces of wires and install a light bulb on to the holder.
4. You have other two ends of the wire free.
5. Fix a two-pin plug on those free pairs of wires. It means you can light up the bulb if you put two-pin plug in a live two-pin socket.
6. Check the continuity of the test lamp is sure that bulb turns on when the plug is inserted in a live two-pin socket.
7. Now, pull out the plug from the socket.
8. Finally, you need to slice one of the wires in the middle and remove insulation from each of the cut-ends for half an inch so that the bare copper is clearly visible.
9. Your test lamp is ready for experimental test. Always use a cap to cover the bare copper wire to avoid any accidental electrification.

### 1.3.3 Series and Parallel circuits

The electrical and electronic circuit are arranged in many ways. The circuit is named based on the way components are connected. There are two of the simplest form of circuit known as *Series and Parallel*.

## Series Circuits

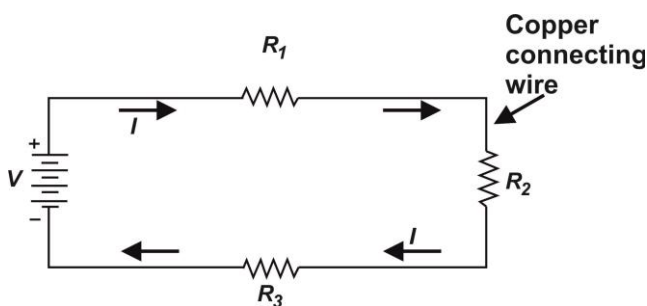
In a series circuit, electric load is connected along a single path in the circuit. So, the current flowing through each of them will remain same. Since, there is only one path for the electrical current to flow through, if a wire is cut or switch is opened, all electric loads in the circuit will stop working. If a battery has insufficient charge or energy, there is insufficient current through the circuit to make the lights glow. In this case battery may be replaced, or putting two batteries in series, may solve this problem. In the series circuit as shown in *figure 1.24*, arrow shows the direction of the flow of current.

A Series circuit or “*series-connected circuit*” is a circuit having just one current path. Thus, *figure 1.24* is an example of a “*series circuit*” in which a battery of constant potential difference  $V$ , and three resistances, are all connected “*in series.*”

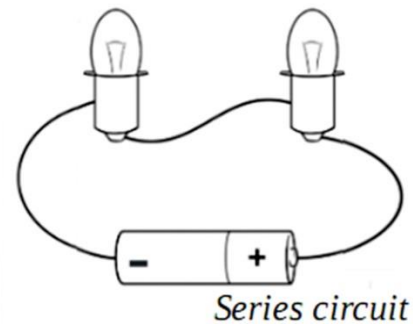
Since a series circuit has just one current path, it follows that all the components in a series circuit carry the same current  $I$ , a fact evident from inspection of *figure 1.24*.

In a series circuit, the total resistance,  $R_T$  is equal to the sum of the individual resistances. Thus, in the particular case of *figure 1.24* the total resistance,  $R_T = R_1 + R_2 + R_3$ , while in the general case of “ $n$ ” resistances connected in series the total resistance is as follows:

$$R_T = R_1 + R_2 + R_3 + \dots + R_n$$



**Fig. 1.24: Series circuit**



**Fig. 1.25 Bulbs connected in series**

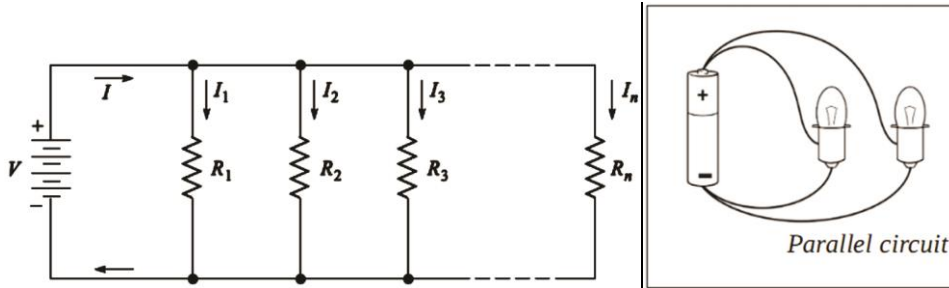
## Parallel Circuits

In a parallel circuit, electric load in the circuit form multiple paths. Since, there are a number of paths, even if one electric load stops working, the other electric loads in the circuit will still work. The current from the source divides, so some of the current flows through one path and the rest through other paths. This means that the power source must supply more current to power a parallel circuit than a series circuit, which may run down the battery faster. In parallel circuit shown in *figure 1.27*, arrows represent direction of flow of currents.

Parallel circuit is one in which the battery current are divided into a number of “*parallel paths.*”

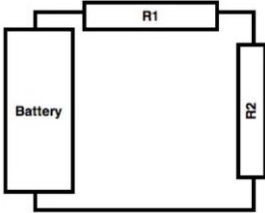
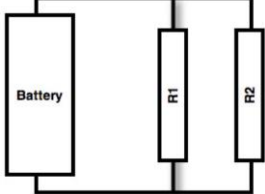
Total resistance of the parallel circuit is as follows:

$$R_T = (R_1 \times R_2 \times R_3 \times \dots \times R_n) / (R_1 + R_2 + R_3 + \dots + R_n)$$



**Fig.1.26: Parallel circuit**

**Fig.1.27 Bulbs connected in parallel**

| Key Concept   | Diagram   |
|---|---|
| <p>For a <b>series circuit</b>, <math>R_1</math> is said to be in series with <math>R_2</math>. For these circuits, the current flowing through each device in series is the same. Adding the voltages across each element in series is equal to the total (battery) voltage.</p> |  <p style="text-align: center;"><b>Fig.1.28(a)</b></p>   |
| <p>For a <b>parallel circuit</b>, <math>R_1</math> is said to be in parallel with <math>R_2</math>. For these circuits, the voltage across each device in parallel is the same. Adding the current through each element in parallel is equal to the total (battery) current.</p>  |  <p style="text-align: center;"><b>Fig.1.28(b)</b></p> |

**Practical Assignment: Build the series and parallel connections of resistors and calculate the resistance.**

Set up a circuit in which three resistors of different values are connected in series and in parallel. Then manually calculate the value of total resistance in both series and parallel connection. Verify the values using ohmmeter.

### 1.3.4 Simple Circuit Drawings

Draw more than one way to light the bulb. Can you do it with one wire? Can you do it with two wires? How many different ways can you think of?

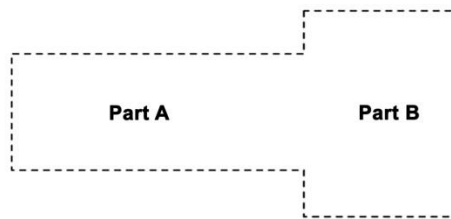
## Building a Bulb Holder

### Materials:

- a) Cardboard, thin, 15 cm x 6 cm
- b) Aluminium foil, 6 cm x 4 cm
- c) Scissors
- d) Glue stick
- e) Push pin
- f) Pen
- g) Light bulb
- h) Electrical insulation Tape

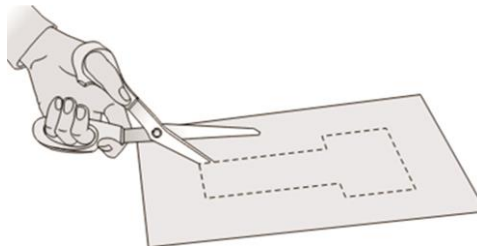
### Directions:

1. Cut out the shape as shown in *figure 1.29*.



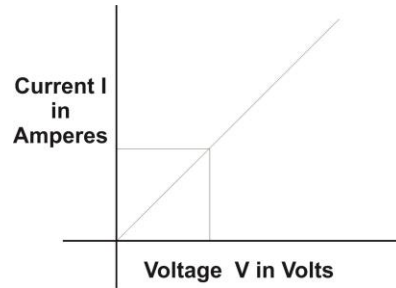
**Figure 1.29**

2. Lay the shape on top of the cardboard, use the pen to trace around it, and then cut out the piece of cardboard as shown in *figure 1.30*.



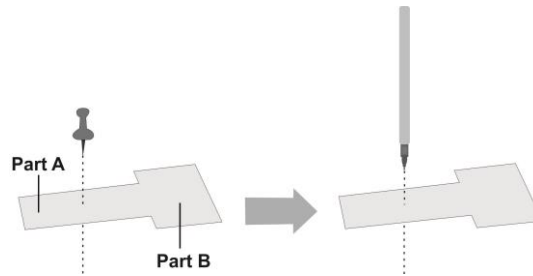
**Figure 1.30**

3. Glue the piece of aluminium foil onto part B of bulb holder as shown in *figure 1.31*.



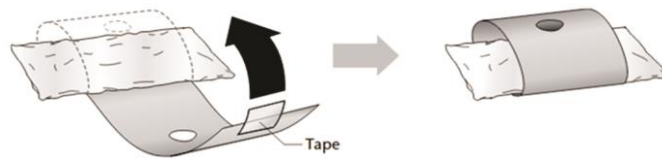
**Figure 1.31**

- Use a push pin to poke a hole near the middle of part as shown in *figure 1.32*. Part A uses a pen to widen the hole.



**Figure 1.32**

- Make sure the hole is large enough for a bulb to fit into it. Then loop part A around the backside of part B. Tape it into place using electrical insulation tape in *figure 1.33*.



**Figure 1.33**

### **Practical Activity: Using Bulb Holders**

#### **Materials:**

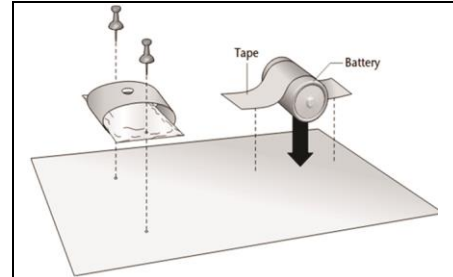
- Bulb holder
- Light bulb
- Cardboard, 20 cm x 15 cm
- Battery
- 2 brads
- Push pin
- Pen
- 2 connecting wires (stripped on each end), 15 cm long



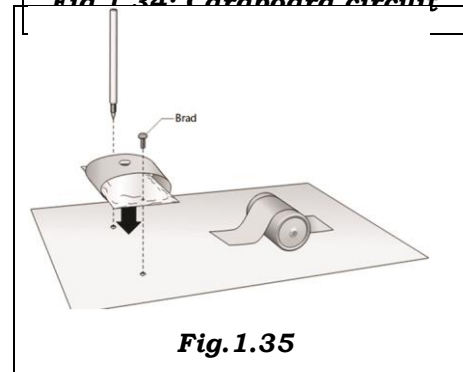
## 9. Electrical insulation tape

### Directions:

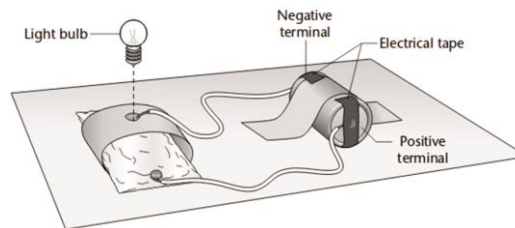
- Attach the battery to the cardboard circuit board by moving it down towards a narrow side of the cardboard.
- Prepare to attach the bulb holder to the cardboard circuit board by using a push pin to poke holes in the bulb holder and the cardboard circuit board.
- Use the tip of a pen to widen the holes and then use brads to lock the bulb holder in place on the circuit board as shown in *figure1.34*.
- Tape one end of a connecting wire to a terminal of the battery. Wrap the other end around a bulb holder brad.
- Tape one end of the other connecting wire to the battery's other terminal. Lay the other end into the bulb holder hole as shown in *figure1.35*.
- Place the bulb into the bulb holder. Make sure the bottom of the bulb is touching the aluminium foil as shown in *figure1.36*.



**Fig. 1.34: Cardboard circuit**



**Fig. 1.35**



**Fig.1.36**

### 1.4 OHM'S LAW

Georg Simon Ohm (16 March 1789 – 6 July 1854) was a German physicist and mathematician. As a school teacher, Ohm began his research with the new electrochemical cell. He investigated the relation between current and voltage in a resistor and published his experimental results in 1827. Ohm's Law can be used to understand the behaviour of electricity in individual components as well as in entire circuits.

### 1.4.1 Ohm's Experiment

A D.C. variable supply voltage is connected with positive terminal at point 'a' and negative terminal at 'b' as shown in *fig.1.37*. As voltage is increased, the current recorded by the ammeter increases. For every voltage value the current is recorded and the corresponding point is plotted on the graph. With this a straight line graph passing through origin is obtained in first quadrant.

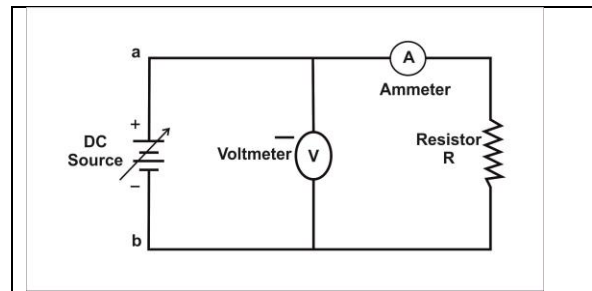


Fig.1.37

### Experiment Results

The experimental results indicate that there is a linear relationship between the current and voltage both in the first and third quadrant. The slope of straight line is also same in both the quadrants which shows that the potential difference across the terminals of the conductor is proportional to the current passing through it i.e.  $V \propto I$ .

Also it is found that for a constant current in the conductor resistance should be changed proportional to the potential difference i.e.  $V \propto R$ .

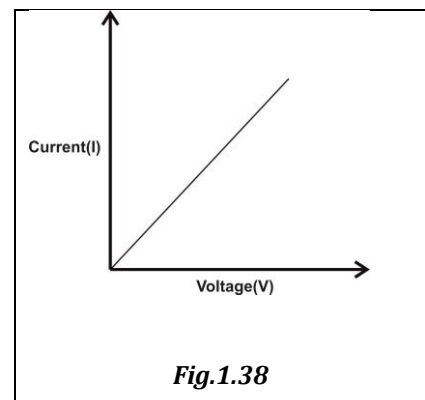


Fig.1.38

Combining the two proportionalities, we have,

$$V \propto IR$$

$$\text{Or } V = k (I \times R)$$

Where,  $k$  is a constant of proportionality. However, the units of voltage, current and resistance are defined, so that the value of  $k = 1$ . When the current is 1 ampere, voltage 1 volt, the resistance is  $1\Omega$ .

$$1 = k \cdot 1 \cdot 1$$

Thus the equation becomes

$$V = IR$$

Thus, Ohms law states that "Current is directly proportional to the applied voltage" or "The current in a conductor is directly proportional to the potential difference between the terminals of the conductor and inversely proportional to the resistance of the conductor".

It means that, if the resistance is kept constant, as the voltage increases, the current increases and if the voltage decreases, then the current decreases. Also, if the voltage remains constant, as the resistance increases the current goes on decreasing and vice versa. It means, keeping the voltage constant, the resistance is inversely proportional to current. It means that, if the resistance increases the current decreases and if the resistance decreases the current increases.

Thus from the ohm's law we have

$$V = I R$$

where,

'V' = voltage applied to the conductor.

'I' = current flowing to the conductor.

'R' = resistance of the conductor.

**Practical Activity:** verification of ohm's law.

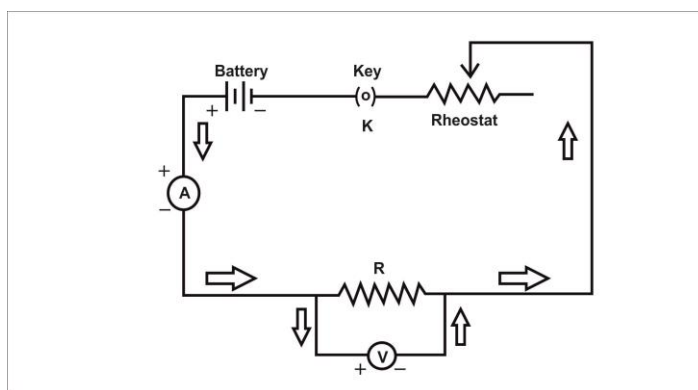
**Material required:**

A resistor of about  $5 \Omega$ , an ammeter (0 - 3 A), a voltmeter (0 - 10 V), four dry cells of 1.5 V each with a cell holder (or a battery), a plug key, connecting wires, and a piece of sand paper.

**Precautions:**

- All the electrical connections must be neat and tight.
- Voltmeter and Ammeter must be of proper range.
- The key should be inserted only while taking readings.

**Circuit Diagram:**



*Fig.1.39*

**Procedure:**

1. Draw the circuit diagram as shown above.
2. Arrange the apparatus as per the circuit diagram.
3. Clean the ends of the connecting wires with sand paper and make them shiny.
4. Make the connections as per circuit diagram. All connections must be neat and tight. Take care to connect the ammeter and voltmeter with their correct polarity. (+ve to +ve and -ve to -ve).
5. Determine the zero error and least count of the ammeter and voltmeter and record them.
6. Adjust the rheostat to pass a low current.
7. Insert the key K and slide the rheostat contact to see whether the ammeter and voltmeter are showing deflections properly.
8. Adjust the rheostat to get a small deflection in ammeter and voltmeter.
9. Record the readings of the ammeter and voltmeter.

10. Take at least six sets of readings by adjusting the rheostat gradually.
11. Plot a graph with '**V**' along x-axis and '**I**' along y-axis.
12. The graph will be a straight line which verifies Ohm's law.
13. Determine the slope of the V-I graph. The reciprocal of the slope gives resistance of the wire.

**Observations:**

- Range of the given ammeter =..... A.
- Least count of the given ammeter =..... A.
- Range of the given voltmeter = .....V.
- Least count of the given voltmeter = .....V.
- Mean value of V/I from observations, R =.....  $\Omega$ .

**Observation from graph:**

- Slope of 'I' vs 'V' graph =.....
- R from graph = 1/ slope =.....  $\Omega$ .

**Observation table:**

| Voltage across (V) | Current through(A) |
|--------------------|--------------------|
| 0                  | 0                  |
| 2                  | .5                 |
| 4                  | 1                  |
| 6                  | 1.5                |
| 8                  | 2                  |
| 10                 | 2.5                |
| 12                 | 3                  |

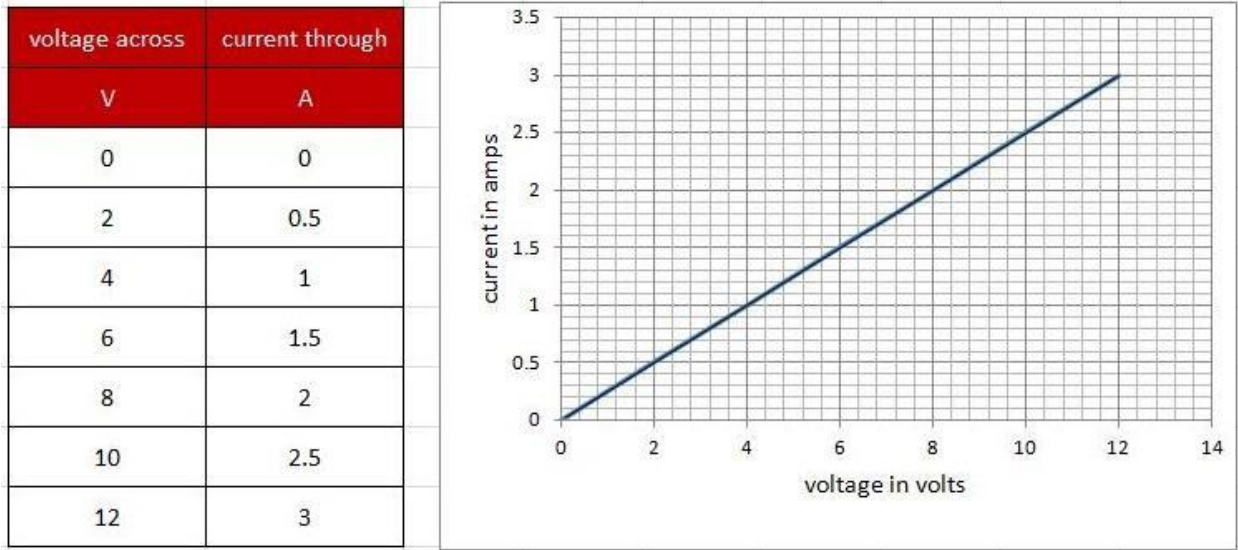


Fig.1.40

**Practical Activity: Verify ohm's law in the given electrical circuit**

In this practical, verify the ohms law by observing the reading in ammeter and voltmeter, draw the graph by plotting the observed values.

**Apparatus required:** Rheostat, Ammeter, Voltmeter, a variable voltage supply of (0-10V) D.C.

**Procedure:**

- Using the DC circuit trainer, connect the circuit as shown in figure 1.41.
- Connect the variable voltage supply to both the ends of the rheostat as shown in the circuit diagram.
- Connect the ammeter in series of the rheostat as shown in the circuit diagram.
- Connect the voltmeter in parallel of the rheostat as shown in the circuit diagram.
- Now, start measuring the voltage and current by varying the position of rheostat's knob from minimum position to the maximum position.

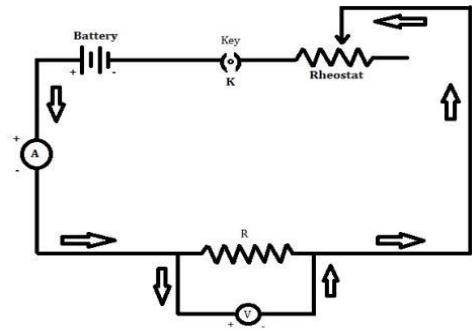
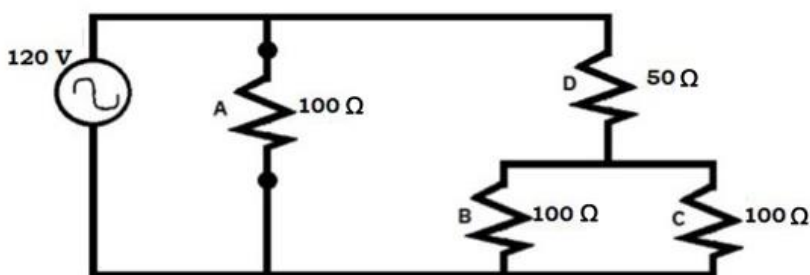


Fig.1.41 Circuit diagram of ohms law,  
Courtesy: <http://bit.ly/2ndWS5T>

6. When rheostat knob is at minimum position, maximum current will flow through the circuit and vice versa.
7. Increase the voltage from 0-10 V and measure current in each step, and then record it in table below.

| V (Volt) | 0 | 1 | 2 | 3 | 4 | 5 | 6 | 7 | 8 | 9 | 10 |
|----------|---|---|---|---|---|---|---|---|---|---|----|
| I (mA)   |   |   |   |   |   |   |   |   |   |   |    |

8. Observe number of reading; fill them all in the table.
9. Now with this data plot a graph between the voltage and the current.



**Fig. A, Courtesy: <http://bit.ly/2ndWS5T>**

### Problems on Ohm's Law

Some of the solved examples to better understand the ohms law are as follows:

**Example 1:** A 10 V battery is connected to the electric bulb of resistance of 20 Ω. Find the current flowing through the electric bulb.

**Solution:**

Here

$$V = 10 \text{ V}$$

$$R = 20 \text{ } \Omega$$

The current flowing through the electric bulb is given by

$$V = I R$$

$$I = V/R$$

$$I = 10/20$$

$$I = 0.5 \text{ A}$$

So, the current flowing through the bulb is 0.5 A.

**Example 2:** An electric iron of resistance 40 Ω is connected to a supply voltage. The current flowing through the electric iron is 6 A. Find the voltage applied to the electric iron?

**Solution:** Here,  $I = 6 \text{ A}$ ,  $R = 40 \text{ } \Omega$

Voltage equation is given by

$$V = I R$$

So, Voltage is expressed as  $V = 6 \times 40$ ,

$$V = 240 \text{ V}$$

**Example 3:** A 110 V voltage source supplies power to a halogen light. The current flowing through the halogen light is 5 A. Find the resistance of the halogen light.

**Solution:** Here,  $V=110\text{V}$ ,  $I=5\text{A}$

The resistance is given by

$$R = V / I$$

$$R = 110/5$$

$$R = 22 \Omega$$

so, the resistance of halogen light is  $22 \Omega$ .

**Assignment:** Solve the problems based on ohm's law.

1. 9 V is applied across a  $3 \Omega$  resistor. What is the current flowing?
2. A  $6 \Omega$  resistor passes a current of 2 A. What is the voltage across it?
3. What is the voltage of a circuit with a resistance of  $255 \Omega$  and a current of 3 A?
4. A small electrical pump is labeled with a rating of 5 A and a resistance of  $30 \Omega$ . At what voltage is it designed to operate?
5. A 9 V battery is hooked up to a light bulb with a rating of  $2 \Omega$ . How much current passes through the light?
6. A lamp is plugged into the wall outlet, which is providing 110 V. An ammeter attached to the lamp shows 2 A flowing through the circuit. How many ohms of resistance is the lamp providing?
7. If your skin has a resistance of  $9000 \Omega$  and you touch a 9 V battery, what current will flow through you?
8. What current will flow through your body with a skin resistance of  $12,000 \Omega$ , if you touch 120 V house potential?
9. When you are soaked in seawater, your resistance is lowered to  $1000 \Omega$ . Now how much current will flow through you if you touch the 9 V battery?
10. When you are soaked in seawater, what current will flow through you if you touch the 120 V house potential?

**Assignment:** Write the electrical symbols and units

Complete the following table of electrical symbols and units:

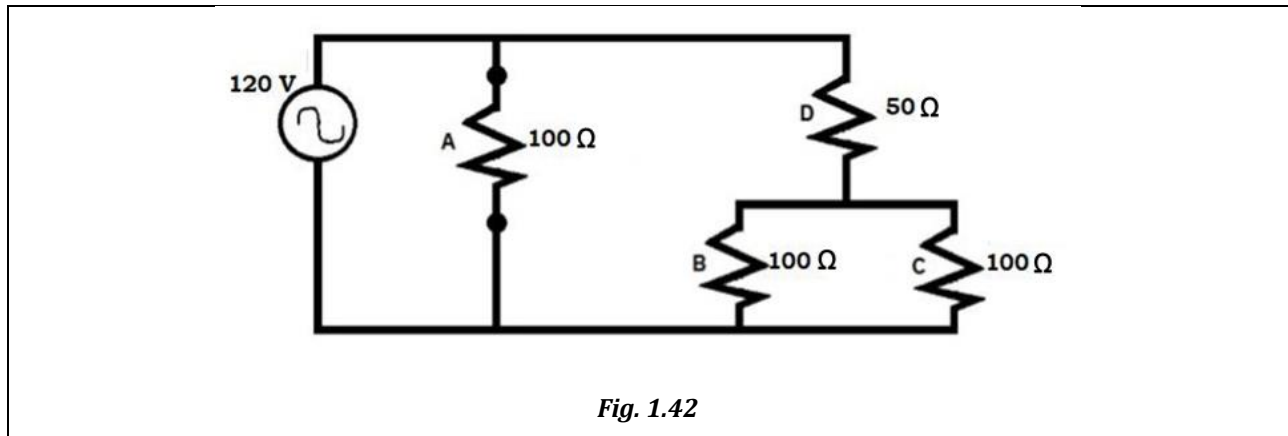


|        | Current | Voltage | Resistance |
|--------|---------|---------|------------|
| Symbol |         |         |            |
| Unit   |         |         |            |

**Assignment:** In the following table, from the given quantities, calculate the unknown quantities. The unit 'k' stands for kilowatt (kW), means 1000 W.

| Voltage | Current | Resistance   | Power  |
|---------|---------|--------------|--------|
| 100 V   | 5A      |              |        |
| 12 V    |         | 1 $\Omega$   |        |
|         | 5A      | 8 $\Omega$   |        |
| 230 V   | 13A     |              |        |
|         | 3A      | 150 $\Omega$ |        |
| 50 V    |         | 20 $\Omega$  |        |
|         |         | 40 $\Omega$  | 1 kW   |
|         | 0.5 A   |              | 2.5 W  |
| 250 V   |         |              | 62.5 W |

**Practical Assignment:** Find the electrical quantities in the circuit shown in figure 1.42.



1. Calculate the equivalent resistance of this circuit.
2. Calculate the total current drawn.
3. Calculate the voltage across following:

Resistor 'A' .....

Resistor 'B' .....

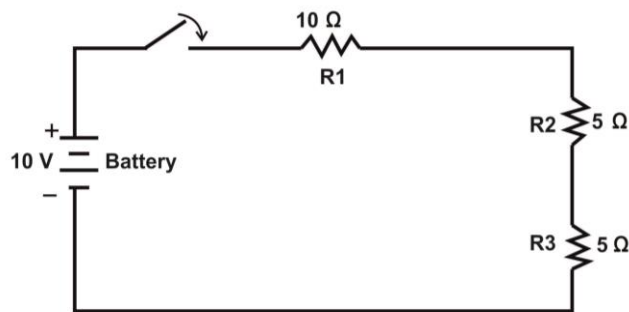
Resistor 'C' .....

Resistor 'D' .....

4. Calculate the amount of power consumed by the circuit.

**Practical Assignment:** Find the following quantities for the circuit in the *figure 1.43*.

1. Calculate the voltage across each load when switch is open.
2. Calculate the current drawn from the battery.
3. Calculate the voltage drop across each resistor.
4. Calculate the equivalent resistance in the circuit.



*Fig1.43*

### 1.5 KIRCHHOFF'S LAW

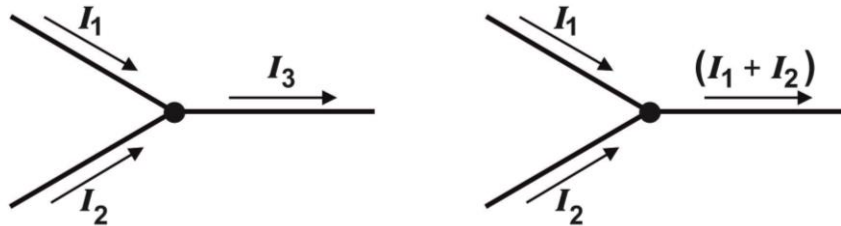
Kirchhoff's law is named after Gustav Kirchhoff, he is a German physicist. Kirchhoff defined the basic relationship between *voltage (V)*, *current (I)*. These laws of Kirchhoff are used for circuit analysis. Kirchhoff's laws relate to the conservation of energy, which states that energy cannot be created or destroyed, only changed into different forms. This can be expanded to laws of conservation of voltage and current. In any circuit, the voltage across each series component (carrying the same current) can be added to find the total voltage. Similarly, the total current entering a junction in a circuit must equal the sum of current leaving the junction. Kirchhoff laws are classified as:

1. Kirchhoff's current law
2. Kirchhoff's voltage law

#### 1.5.1 Kirchhoff's Current Law (KCL)

Kirchhoff's current law states that "total incoming currents at a point are equal to the total outgoing currents". It can be understood by an example, consider that  $I_1$  and  $I_2$  are coming towards a point. Current  $I_1$  and  $I_2$  are incoming

current as they are coming towards point as shown in the *figure1.44*. Current  $I_3$  is outgoing current w.r.t point. The sum of incoming currents  $I_1$  and  $I_2$  are equal to the sum of outgoing current  $I_3$ .

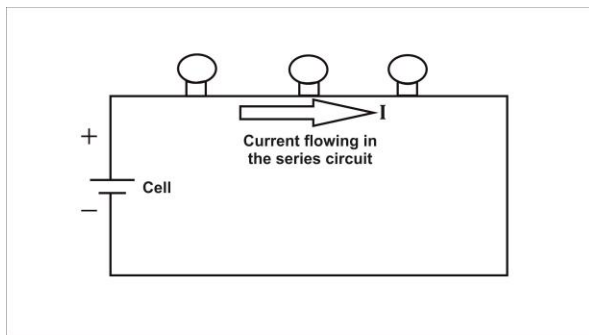


**Fig.1.44, Courtesy: <http://bit.ly/2AYNyML>**

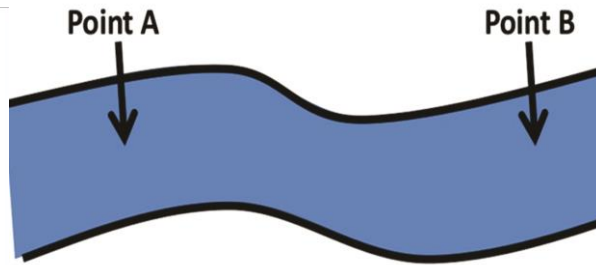
Mathematically, at a point

$$I_1 + I_2 = I_3$$

In a series circuit total current flowing in the circuit remains same at any point in the circuit.



**Fig. 1.45: Series Circuit**

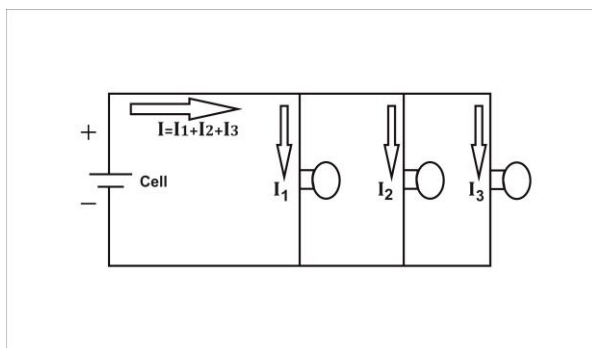


**Same current**

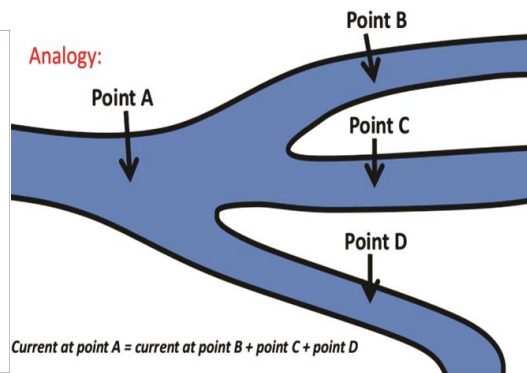
**Fig.1.46: Analogy of current in series circuit**

**Courtesy: <https://goo.gl/VzW2Pu>**

In a parallel circuit total current flowing in the circuit is divided in parallel branches.



**Fig.1.47: Parallel circuit**



**Current at point A = current at point B + point C + point D**

**Fig.1.48: Analogy of current in parallel circuit**

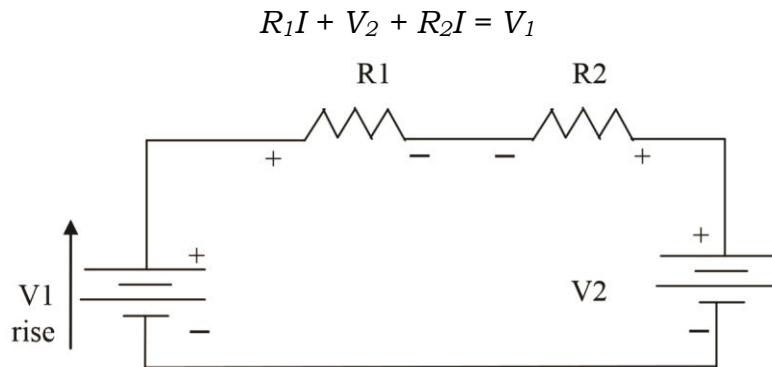
### 1.5.2 Kirchhoff's Voltage Law (KVL)

Kirchhoff's voltage law states that "total voltage drop across the loads in the circuit are equal to the total voltage applied to the circuit" or "the algebraic sum of the products of currents and resistance in each of the conductors in any closed path (or mesh) in a network plus the algebraic sum of the E.M.F. in that path is zero".

In other words,  $\sum IR + \sum \text{E.M.F.} = 0$

EMF stands for electro motive force; it is the force which exerts on the electrons to move from one place to another.

Let us now write the equation for *figure 1.49* in accordance with Kirchhoff's voltage law. To do this, we start at any point and move completely around the circuit, listing the "voltage drops" and the "voltage rises" as we go. (In doing this, remember that we have defined that going from "minus to plus" constitutes a rise in voltage and going from "plus to minus" constitutes a drop in voltage.) Thus, if we agree to list all "voltage drops" on the left-hand sides of our equations and all the "voltage rises" on the right-hand sides, the Kirchhoff voltage equation for *figure 1.49* is:



**Fig. 1.49, Courtesy: <http://bit.ly/2AYNyML>**

Note that  $V_2$  appears as a voltage drop, because we go through that battery from plus to minus (+ to -). Alternatively, putting all the battery voltages on the right hand side, the above equation becomes

$$R_1I + R_2I = V_1 - V_2$$

Hence,  $I = (V_1 - V_2) / (R_1 + R_2)$

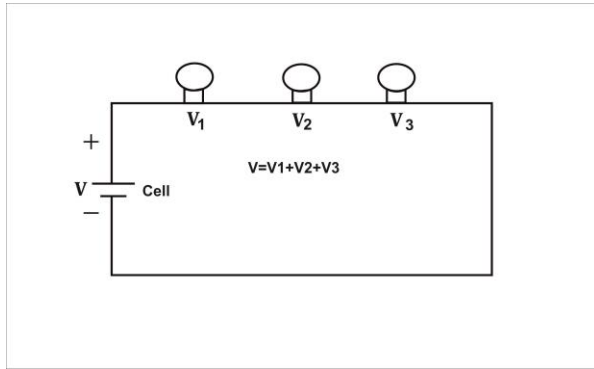
It can be understood by an example, consider a circuit in which three loads are used i.e.  $R_1, R_2, R_3$ . Total applied voltage to the circuit is  $V$ . Voltage drop across the loads are  $V_1, V_2, V_3$ . Therefore, according to Kirchhoff's voltage law total applied voltage ( $V$ ) is equal to the sum of individual voltage drop ( $V_1, V_2, V_3$ ) across the loads.

Mathematically,

$$V=V_1+V_2+V_3$$

As shown in the *figure 1.50* voltage drop across the loads are 5V, 2V, 3V. Total applied voltage is 10V.

$$10V = 5V + 2V + 3V$$



**Fig.1.50: Series circuit**

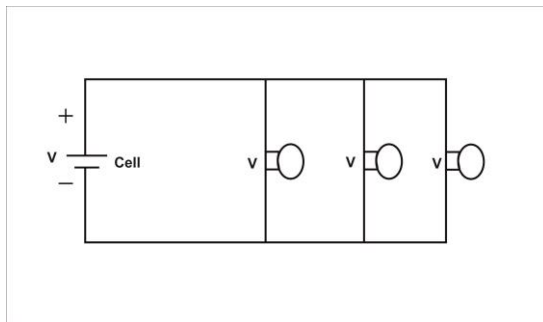
Analogy:



**Fig.1.51: Analogy of voltage in series circuit**

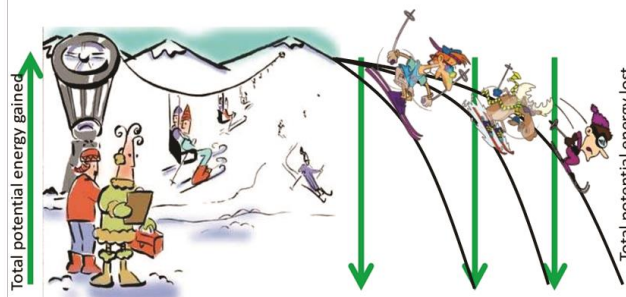
Courtesy: <https://goo.gl/VzW2Pu>

In a parallel circuit, the total voltage provide by the source is equal to the voltage across each parallel branch.



**Fig.1.52: Parallel Circuit**

Analogy:



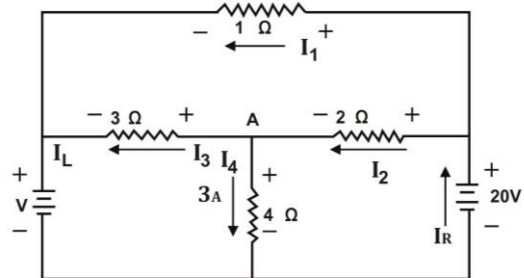
**Fig. 1.53: Analogy of voltage in parallel circuit**

Courtesy: <https://goo.gl/VzW2Pu>

### 1.5.3 Analysis of Kirchhoff's law:

Circuit in *figure1.54*, below with 3 A of current running through the 4 Ω resistor as indicated in the figure.

1. Determine the current through each of the other resistors.
2. Determine the voltage of the battery on the left.
3. Determine the power delivered to the circuit by the battery on the right.



**Fig. 1.54**

- Identify the currents through the resistors by the value of the resistor ( $I_1, I_2, I_3, I_4$ ) and the currents flowing through the batteries are  $I_{\text{Left}}$  (current flowing from battery at the left side) and  $I_{\text{Right}}$  (current flowing from battery at the right side).
- Start with the  $2\Omega$  resistors. Apply the loop rule to the circuit on the lower right.

$$20 \text{ V} = I_2(2\Omega) + (3\text{A})(4\Omega)$$

$$I_2 = 4\text{A}$$

- Start the circuit analysis from  $3\Omega$  resistors. Apply the junction rule at point A in the center of the circuit.

$$I_2 = I_3 + I_4$$

$$4\text{A} = I_3 + 3\text{A}$$

$$I_3 = 1\text{A}$$

- The current through the  $1\Omega$  resistor certainly runs from right to left. If we apply the loop rule to the top circuit, we will have to run against that current. This changes what is normally considered a potential drop into a potential increase.

$$I_1(1\Omega) = (4\text{A})(2\Omega) + (1\text{A})(3\Omega)$$

$$I_1 = 11\text{A}$$

- Apply the loop rule to the outer circuit to get the voltage of the battery on the left (continuing with the assumption that the current is running counterclockwise). We find ourselves running through the left battery backwards. This changes what is normally considered a higher potential into a lower potential.

$$20\text{V} = (11\text{A})(1\Omega) + V_L$$

$$V_L = 9\text{V}$$

- Let's verify this result by repeating the procedure for the bottom circuit.

$$20 \text{ V} = (4\text{A})(2\Omega) + (1\text{A})(3\Omega) + V_L$$

$$V_L = 9 \text{ V}$$

- The power delivered to the circuit by the battery on the right is the product of its voltage times the current it drives around the circuit. We already have the voltage (it's given in the problem) all that remains is to determine the current. Apply the junction rule to the junction on the left.

$$I_L = I_1 + I_3$$

$$I_L = 11\text{A} + 1\text{A}$$

$$I_L = 12\text{A}$$

and again to the junction at the bottom

$$I_R = I_L + I_4$$

$$I_R = 12\text{A} + 3\text{A}$$

$$I_R = 15\text{A}$$

- To find the power of the battery on the right

$$P = VI$$

$$P = (20\text{V})(15\text{A})$$

$$P = 300\text{W}$$

**Practical Assignment:** Determine the current through each resistor in the circuit shown below.

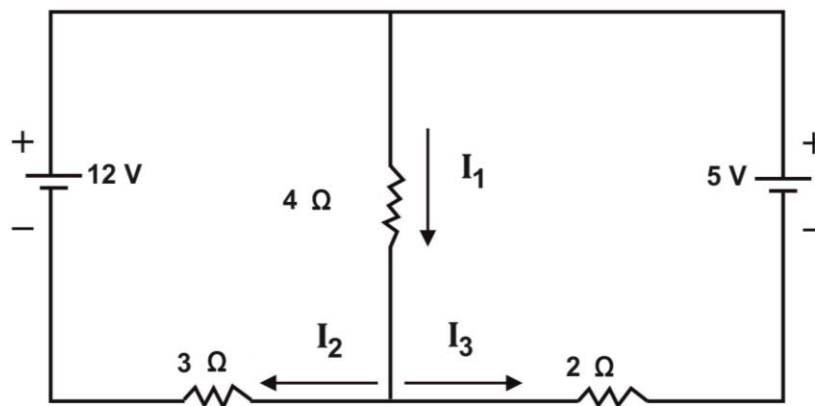


Fig.1.55

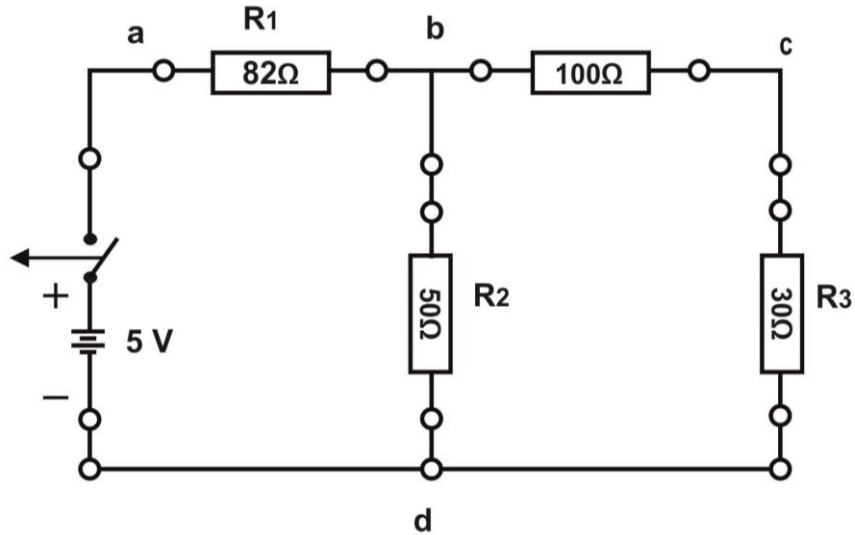
#### 1.5.4 Kirchhoff's Law practical

In this practical, verify the Kirchhoff's law by observing the reading in ammeter and voltmeter as shown in *figure 1.56*.

**Apparatus required:** Resistance of  $30\ \Omega$  ,  $50\ \Omega$  ,  $82\ \Omega$  and  $100\ \Omega$  , connecting cords, power supply.

#### Procedure

- a) Using the DC circuit trainer, Connect the circuit shown below:



**Fig. 1.56, Courtesy: <http://bit.ly/2AYNyML>**

- b) Measure the values of voltage and current of each resistor in circuit and record it in the table below.

|          | R <sub>1</sub> (ohm) | R <sub>2</sub> (ohm) | R <sub>3</sub> (ohm) | R <sub>4</sub> (ohm) |
|----------|----------------------|----------------------|----------------------|----------------------|
| I (mA)   |                      |                      |                      |                      |
| V (Volt) |                      |                      |                      |                      |

- c) Measure the voltage and current values across the resistor R<sub>1</sub>, resistor R<sub>2</sub>, resistor R<sub>3</sub>, and resistor R<sub>4</sub> note the reading in the table. Observe the total voltage applied in the circuit and the voltage drop across the individual resistor.

### **Practical Activity: Energy use in Home Appliances**

#### **Calculation of energy**

To calculate the energy consumption in home appliance following technique is used. We know that:

$$\text{Power} = \text{Energy} / \text{Time}$$

or

$$\text{Energy} = \text{Power} \times \text{Duration of Usage (Time)}$$

By modifying this formula slightly, we can determine Energy Consumption per Day:

$$\text{Energy Consumption / Day} = \text{Power Consumption} \times \text{Hours Used / Day}$$

Where:

1. **Energy Consumption** will be measured in Kilowatt hour (kWh) -



like on your utility bills.

2. **Power Consumption** will be measured in Watt
3. **Hours used per Day** will be the actual time you use the appliance.

Since we want to measure energy consumption in kilowatt hour, we must change the way power consumption is measured from Watt to Kilowatt (kWh). We know that 1 kilowatt hour (kWh) = 1,000 watt hours, so we can adjust the formula above to:

Energy Consumption / Day (kWh) = Power Consumption (Watt / 1000) x Hours Used / Day

### **Example 1: Calculating energy use of a ceiling fan**

**Solution:** If you use a ceiling fan (200 W) for four hours per day, and for 120 days per year, what would be the annual energy consumption?

Use this formula:

Energy Consumption / Day (kWh) = Power Consumption (Watts / 1000) x Hours Used / Day

Energy Consumption per Day (kWh) = (200 / 1000) x 4 (Hours used per day).  
Energy Consumption per Day (kWh) = (1/5) x 4 Energy Consumption per Day (kWh) = 4/5 or 0.8, So the energy consumption per day is 0.8 kWh. To find out energy for 120 days, do simple multiplication: 0.8 x 120 = 96 kWh

d) If total applied voltage in the circuit and the voltage drop across the individual resistor are equal, then we can say that Kirchhoff's voltage law is verified.

e)

## **BASIC ELECTRICAL TERMS**

**AC and DC:** Abbreviations for alternating current and direct current respectively.

**Current:** A movement of electricity analogous to the flow of a stream of water.

**Direct Current:** An electric current flowing in one direction only (i.e. current produced using a battery).

**Alternating Current:** A periodic electric current that reverses its direction at regular intervals.

**Ampere:** The unit of electrical current (the measure of electrical flow), is abbreviated A.

**Circuit Breaker:** A device designed to open and close a circuit by non-automatic means and to open the circuit automatically on a predetermined over current without damaging itself when operated according to its rating.

**Circuit:** A complete path from the energy source through conducting bodies and back to the energy source.

**Conductor:** a substance or body capable of conducting electricity.

**Equipment:** A general term including material, fittings, devices, appliances, fixtures, apparatus, and similar items used as a part of, or in connection with, an electrical installation.

**Fuse:** An over current protective device with a circuit opening part that is heated and broken by the passage of an over current through it.

**Kilowatt-hour:** Work done at the steady rate equivalent to 1000 watt in one hour. Power utility companies' base their billing upon the number of kilowatt-hours (kWh) consumed.

**Lamp:** A general term for various devices for artificially producing light.

**Ohm:** The unit of electrical resistance and impedance, abbreviated with the symbol omega,  $\Omega$ . Resistance is the opposition offered by a substance to the passage of electrical current. Impedance is the apparent resistance in a circuit to the flow of alternating current.

**Ohm's Law:** A statement of the relationship, discovered by the German scientist G. S. Ohm, between the voltage, amperage and resistance of a circuit. It states the voltage of a circuit in volts is equal to the product of the amperage in amperes and the resistance in ohms,  $V=IR$ .

**Over current:** Any current in excess of the rated current or ampacity. It may result from overload, short circuit or ground fault.

**Transformer:** An apparatus for converting an alternating electrical current from a high to a low potential (voltage) or vice versa. Transformers only change voltage and amperage.

**Volt:** It is a unit of electric potential and is abbreviated as 'V'.

**Watt:** the unit of power or rate of work represented by a current of one ampere through a potential difference of one volt (abbreviated w or W).

## CHECK YOUR PROGRESS

### Q1. Choose the correct option from those given below

1. Which of the following component is used to close or break the circuit
  - a) Bulb
  - b) Switch
  - c) Wire
  - d) Electric Cell
2. Which of the following component is used to provide resistance

- a) Heat
  - b) Energy
  - c) Product
  - d) Resistor
3. Frequency (f) of alternating current is .....hertz in India.
- a) 45
  - b) 60
  - c) 50
  - d) 55
4. In series circuit current remains ..... and voltage.....
- a) Divide, same
  - b) Same, same
  - c) Divide, divide
  - d) Same, divide
5. In parallel circuit current remains..... and voltage .....
- a) Divide, same
  - b) Same, same
  - c) Divide, divide
  - d) Same, divide
6. Amount of work in one second is called as.....
- a) Power
  - b) Current
  - c) Voltage
  - d) Charge
7. Ohms law states that.....
- a) Voltage is directly proportional to the applied voltage.
  - b) Voltage is directly proportional to the applied current.
  - c) Current is directly proportional to the applied voltage.
  - d) Current is directly proportional to the applied current.
8. Amount of charge flowing through a point in one second is called as.....
- a) Voltage
  - b) Current

- c) Power
  - d) Charge
9. Amount of work required to move a unit coulomb charge from point A to point B called as.....
- a) Current
  - b) Charge
  - c) Voltage
  - d) Power
10. What are the basic building blocks that all matter composed of?
- a) Electrons, neutrons, and protons
  - b) Electrons, proton and ions
  - c) Neutrons, protons and ions
  - d) Electrons, neutrons, and charged ions
11. Electric charge can be produced by
- a) Sticking
  - b) Rubbing
  - c) Oiling
  - d) Passing ac current
12. An electron has ..... charge.
- a) Positive
  - b) Negative
  - c) Zero
  - d) Sometime positive, sometimes negative
13. A proton has ..... charge.
- a) Positive
  - b) Negative
  - c) Zero
  - d) Sometimes positive, sometimes negative
14. A neutron has.....charge.
- a) Positive
  - b) Negative
  - c) Zero

- d) Sometimes positive, sometimes negative
15. Unit of electric current is.....
- a) Ampere
  - b) Volt
  - c) Watt
  - d) Joule
16. Unit of electrical power is.....
- a) Volt
  - b) Watt
  - c) Joule
  - d) Ampere
17. The term used to designate electrical pressure is
- a) Voltage
  - b) Watt
  - c) Joule
  - d) Ampere
18. The statement which correctly represents ohm's law:
- a)  $V = IR$
  - b)  $V = R/I$
  - c)  $R = VI$
  - d)  $I = R/V$
19. If  $V = 50 \text{ V}$  and  $I = 5 \text{ A}$ , then  $R = \underline{\hspace{1cm}}$ :
- a)  $50 \Omega$
  - b)  $5 \Omega$
  - c)  $10 \Omega$
  - d)  $2 \Omega$
20. If  $P = 50 \text{ watt}$  and  $R = 2 \Omega$ , then  $I = \underline{\hspace{1cm}}$
- a)  $50 \text{ A}$
  - b)  $5 \text{ A}$
  - c)  $10 \text{ A}$
  - d)  $2 \text{ A}$

21. A current of 3A flow through a conductor whose end are at a potential difference of 6V. Calculate the resistance of the conductor.
- a)  $4 \Omega$
  - b)  $5 \Omega$
  - c)  $1 \Omega$
  - d)  $2 \Omega$
22. Combination of three resistances in series then it is given as:
- a)  $R_1+R_2+R_3$
  - b)  $1/R_1+1/R_2+1/R_3$
  - c)  $R_1 \times R_2 \times R_3$
  - d)  $R_1+R_2 \times R_3$
23. A current of 2A flows through a 12V bulb then Calculate the resistance.
- a) 6
  - b) 16
  - c) 24
  - d) 20
24. Conductors which do not obey the ohms law are called as:
- a) Un-ohmic conductor
  - b) Non-ohmic conductor
  - c) Low-ohmic conductor
  - d) Less-ohmic conductor
25. A complete electric circuit is called as:
- a) Open
  - b) Close
  - c) Incomplete
  - d) Complete
26. Why are copper wires used as connecting wires?
- a) Low resistivity
  - b) Low conductivity
  - c) High resistivity
  - d) None of the above
27. Electrical conductors are materials which contain:

- a) Only positive charge
  - b) Movable electric charge
  - c) Only negative charge
  - d) None of the above
28. How many terminals electric cell consist of?
- a) One
  - b) Three
  - c) Two
  - d) Four
29. Electric cell convert the ..... energy into .....energy.
- a) Electrical to mechanical
  - b) Mechanical to electrical
  - c) Chemical to electrical
  - d) Electrical to chemical
30. Why battery is used in the circuit?
- a) Measure current
  - b) Maintain potential difference
  - c) Oppose the current
  - d) Measure potential

**Q2. Fill in the blanks with correct word**

1. In..... circuit current remains same and voltage divides.
2. In..... circuit current divides and voltage remains same.
3. Amount of ..... in one second is called as power.
4. A component which is used to close or break a circuit is.....
5. Proton has ..... charge.
6. Unit of electrical ..... is watt.
7. "Current is directly proportional to the applied voltage" this law is given by.....
8.  $1\text{kWh} = \dots\dots\dots \text{watt} \times \dots\dots\dots \text{second}$
9. Switch is used for ..... and ..... of circuit.
10. Electrons have ..... charge.
11. The relationship between voltage, current, and resistance by Ohm's Law.

Voltage = Current x Resistance

This will mean that:

$$I = \frac{V}{R} \quad \text{Current} = \dots \div \dots$$

$$\text{and } R = \frac{V}{I} \quad \dots = \dots \div \dots$$

**Q3. State whether the statement given below are True or False**

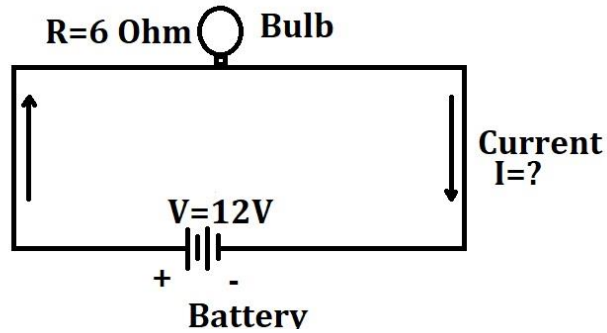
- a) Frequency (f) of alternating current is 60 hertz in India. ( )
- b) Electrons are electrically neutral. ( )
- c) Due to rubbing of two bodies, electric charge is produced. ( )
- d) Relation between voltage, current, resistances is given by Kirchoff's law. ( )
- e) Unit of current is ampere. ( )
- f) Resistor easily passes current. ( )
- g) Unit of voltage is watt. ( )
- h) Unit of power is joule/second. ( )
- i) Current in a circuit is instantly established. ( )
- j) 1kWh = 1000 watt x 3600 second. ( )

**Q4. Short answer type question:**

- a) What is the supply voltage at home?
- b) What is one volt?
- c) What is the supply frequency of supply voltage?
- d) What is electric current?
- e) What does 10 A mean?
- f) Explain diagrammatically, how the components are connected in series circuits?
- g) Explain diagrammatically, how the components are connected in parallel circuits?
- h) Explain diagrammatically, how the components are connected in complex circuits?
- i) What will happen to the series circuit if a bulb gets fused? Will the circuit be close in this case?
- j) List the appliance where resistors are used.
- k) What are the different variable resistors?

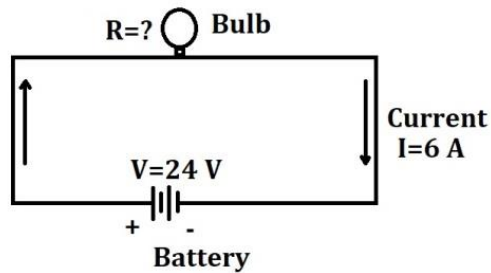


- l) How AC and DC currents are different from each other?
- m) List the appliances which use DC power.
- n) Calculate the current 'I' flowing through the circuit (*figure 1.56*).



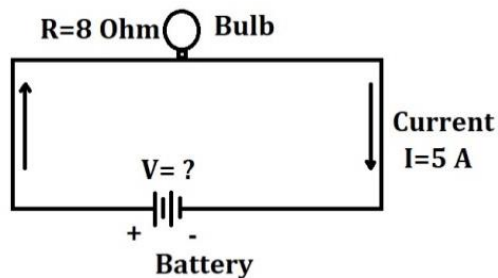
*Fig.1.57*

- a) Calculate the Resistance 'R' in the circuit (*figure 1.57*).



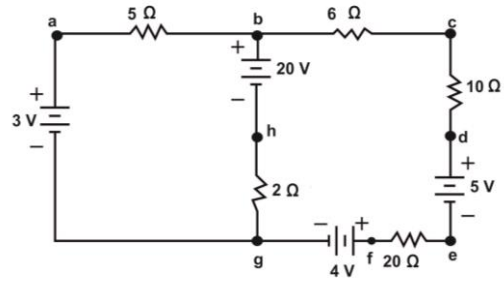
*Fig. 1.58*

- b) Calculate the voltage 'V' in the circuit (*figure 1.58*).



*Fig. 1.59*

- c) Verify the KCL and KVL and find  $I_1$ ,  $I_2$ ,  $I_3$  for the *figure 1.46*.



**Fig. 1.60**

### ELECTRICAL AND ELECTRONIC COMPONENTS

#### 2.0 INTRODUCTION

There are several important basic electrical components that are commonly found in the circuits. These components are the fundamental building blocks of electrical and electronic circuits, and can be found in great numbers on control panel, printed circuit board etc. They can be used and combined with each other in so many different ways that it will form a new circuit. Still, it is useful to know a bit about how they work, and this chapter will provide you with a basis for recognizing some of what you see on those boards, and perhaps understanding the fundamentals of circuit schematics.

Electrical control system includes number of components these components are assembled to form a circuit as shown in *figure 2.1*. It is important to know the detail of the components. Components which are assembled in the control panel must have specific rating. Each component has its data sheet on which details of a component are mentioned.

Before assembling the electrical circuit, technician should have detail knowledge of component and its identification. Technician should able to distinguish the components physically. There are some common components which are used in almost every control system such as resistor, capacitor, integrated circuit, light emitting diode, etc. Technician must know the characteristics of each component, dependence of each component on different parameters, basic construction of each component.



**Fig. 2.1: Basic circuit components**

#### 2.1 RESISTOR

Resistor is one of the fundamental components of an electrical and electronic device as shown in *figure 2.2*. In a simple way resistor opposes movement of electric charge. This opposition is called as resistance. It has two-ends, resistor controls the current flow, and it also drops the



**Fig. 2.2: Resistor, Courtesy: <https://goo.gl/VAeEgv>**

voltage across it, thus lowers the voltage levels within circuits. High-power resistors are used to dissipate electrical power. Resistors can have fixed resistances value. This fixed resistance value can change slightly, only when there is change in temperature, time or operating voltage. Resistors whose value can be changed are called as *variable resistors*. These variable resistors can be used to control different parameters. For example, in radio circuit variable resistor is used as a volume control component.

### **Practical Activity: Identification of resistor**

Resistors are the fundamental component of electrical and electronics industry. Resistor opposes the flow of current in the circuit. Amount of opposition is measured in ohm. Ohmic value mostly printed on the resistor in the form of code. In surface mount resistor ohmic value is printed on the surface, whereas in carbon film resistor ohmic value of resistor is printed in the form of bands of colour code. Learning the codes, along with using a helpful mnemonic device, one can identify resistors easily.

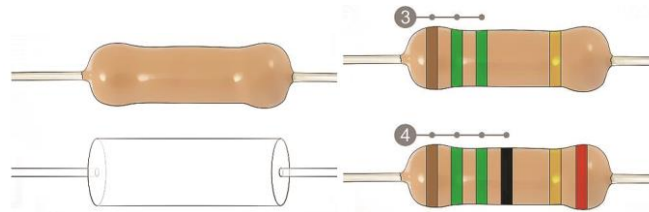
There are two methods for manually reading and identifying the value of a resistor. These are:

- a) Colour Coded Resistors (Axial Resistors)
- b) Alphanumerically Coded Resistors (Surface Mounted Resistors)

### **Colour Coded Resistors (Axial Resistors)**

Axial resistors are cylindrical with leads extending at each end. Axial resistor is colour coded. The basic shape of axial resistor is shown in *figure 2.3(a)*. While, axial resistor colour coded form with 4 or 5 bands is shown in *figure 2.3(b)*.

In *figure 2.1 (b)*, in case of 4 band resistor first two bands represent significant digit, third band represents multiplier and forth band represent tolerance. In case of 5 bands resistor first three bands represent significant digit, forth band represents multiplier and fifth band represent tolerance.



**Fig. 2.3(a) Basic structure of axial resistor Fig. 2.3(b) Colour code band of axial resistor**

Courtesy: <http://bit.ly/2uVGOc9>

Courtesy: <http://bit.ly/2uVGOc9>

Resistors are colour coded, mainly because of the difficulties of writing a value on the side of the resistor and the many errors that would occur.

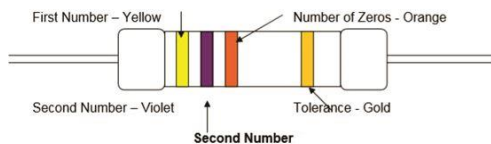
Each colour represents a number according to the following scheme:

| Colour | Number |
|--------|--------|
| black  | 0      |
| brown  | 1      |
| red    | 2      |
| orange | 3      |
| yellow | 4      |
| green  | 5      |
| blue   | 6      |
| violet | 7      |
| grey   | 8      |
| white  | 9      |

**Fig. 2.4 Colour Code**

### Specification of Four Band Resistor

1. The resistor is read this way, with the three colour bands on the left of the resistor and the single band to the right.
2. The first band on a resistor is interpreted as the first number of the resistor value. For the resistor shown below, the first band is yellow, so the first number is 4.



**Fig. 2.5 Four band Resistor Specification**



**Fig. 2.6 Four band resistor**

3. The second band gives the second number. This is a violet band, making the second digit 7.
4. The third band is called the multiplier and gives the number of zeros, in this case 0 orange which is 3.

5. So the value of the resistor is 47000Ω or 47kΩ.
6. The fourth colour gives the tolerance.
7. The tolerance gives an upper and lower value the resistor must be in, take the following example for a 100Ω resistor:

| Tolerance | Colour | Stated Resistor Value | Allowed Upper Value | Allowed Lower Value |
|-----------|--------|-----------------------|---------------------|---------------------|
| ±1%       | brown  | 100Ω                  | 101Ω                | 99Ω                 |
| ±2%       | red    | 100Ω                  | 102Ω                | 98Ω                 |
| ±5%       | gold   | 100Ω                  | 105Ω                | 95Ω                 |
| ±10%      | silver | 100Ω                  | 110Ω                | 90Ω                 |

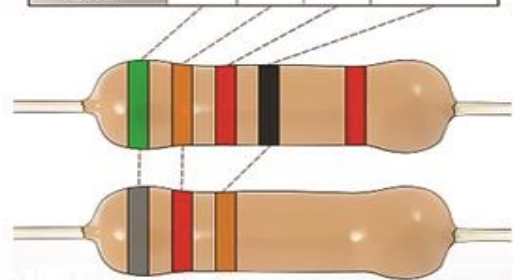
**Fig. 2.7 Tolerance value**

### Calculation of resistor value

Read the colour bands from left to right. The colours on the first 2 or 3 bands correspond to numbers from 0 to 9, which represent the significant digits of the resistor's ohmic value, the last band gives the multiplier (as shown in *figure 2.8*). For example, a 4 bands resistor with brown, brown, yellow and gold bands is rated at  $11 \times 10^4$  or 110 kilo-ohms with 0.1 tolerances. The code is as follows:

- a) Brown: 1 significant digit.
- b) Brown: 1 significant digit.
- c) Yellow: Multiplier of  $10^4$ .
- d) Gold: Tolerance of 1/10
- e) Silver: Tolerance of 1/100

| Color  | Significant figures |   |   | Multiplier |
|--------|---------------------|---|---|------------|
| black  | 0                   | 0 | 0 | 1Ω         |
| brown  | 1                   | 1 | 1 | 10Ω        |
| red    | 2                   | 2 | 2 | 100Ω       |
| orange | 3                   | 3 | 3 | 1KΩ        |
| yellow | 4                   | 4 | 4 | 10KΩ       |
| green  | 5                   | 5 | 5 | 100KΩ      |
| blue   | 6                   | 6 | 6 | 1MΩ        |
| violet | 7                   | 7 | 7 | 10MΩ       |
| grey   | 8                   | 8 | 8 |            |
| white  | 9                   | 9 | 9 |            |
| gold   |                     |   |   |            |
| silver |                     |   |   |            |



**Fig. 2.8 Colour coding chart of resistor**

Courtesy: <http://bit.ly/2uVGOc9>

The last colour band represents the tolerance value of resistor. To calculate the tolerance value of resistor read the colour on the last colour band, which is farthest right. This represents the tolerance of the resistor. If there is no colour band, the tolerance is 20 percent as shown in *figure 2.8*. Most resistors have no band, a silver band or a gold band, but you may find resistors with other colours.

**Practical Activity: Alphanumerically Coded Resistors (Surface Mounted Resistors) identification**

Surface mounted resistors are rectangular in shape as shown in *figure 2.9(a)*. Surface mount resistor have leads which are coming out from the resistor, these leads are used for mounting of resistor on the printed circuit board. Some surface mount resistor uses plates on the bottom side of resistor.



**Fig. 2.9(a)**

Courtesy: <http://bit.ly/2uVGOc9>

The first 2 or 3 numbers printed on the surface mount resistor represents significant digits and the last digit represents the number of zero that should follow. For example, as shown in *figure 2.9 (b)*, a resistor reading 1252 indicates a value 125200 ohm, for tolerance value use the letter at the end of the code.

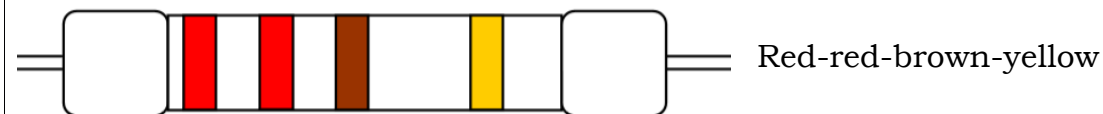
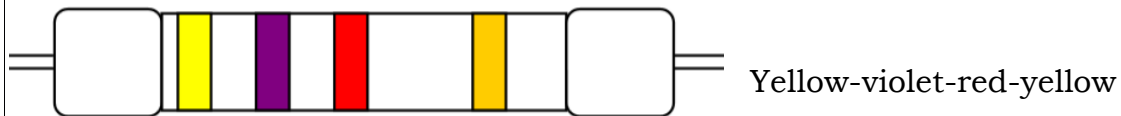


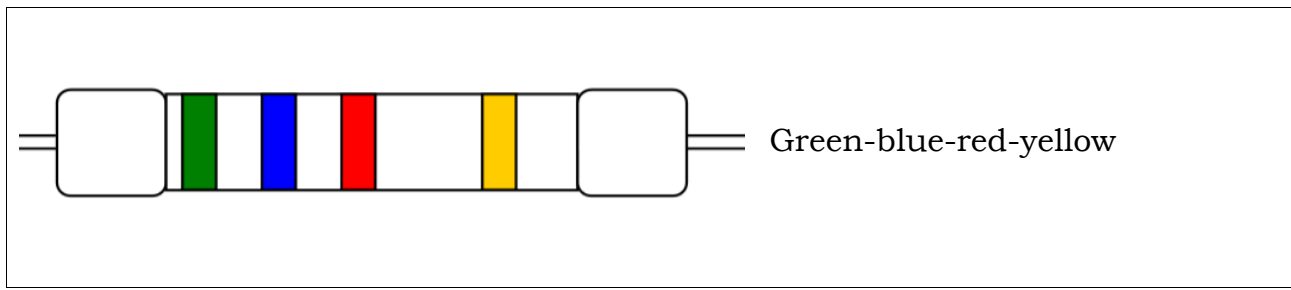
**Fig. 2.9 (b)**

Courtesy: <http://bit.ly/2uVGOc9>

Compare the letter at the end of the code with the tolerance it represents.

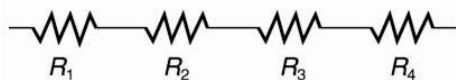
**Practical Activity:** Calculate the value of resistors by using color code.



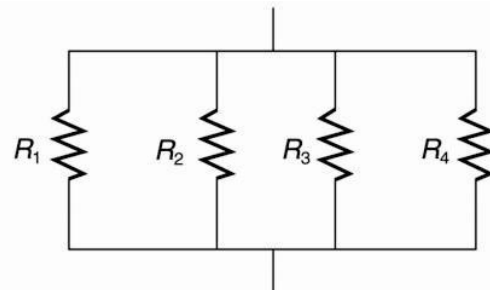


When numbers of resistors are combined together to connect in series or parallel or both, relation between voltage, current and resistance can be derived using ohm's law, Kirchoff's voltage law, Kirchoff's current law.

### 2.1.1 Series connection of resistors:



**Fig. 2.10: Series connection of resistors,**  
 Courtesy: <http://bit.ly/2LMfKq9>



**Fig. 2.11: Parallel connection of resistors,**

$$R_{\text{equivalent}} = R_1 + R_2 + R_3 + \dots$$

Series key idea: Current is the same in each resistor by current law.

### 2.1.2 Parallel connection of resistors:

$$1/R_{\text{equivalent}} = 1/R_1 + 1/R_2 + 1/R_3 + \dots$$

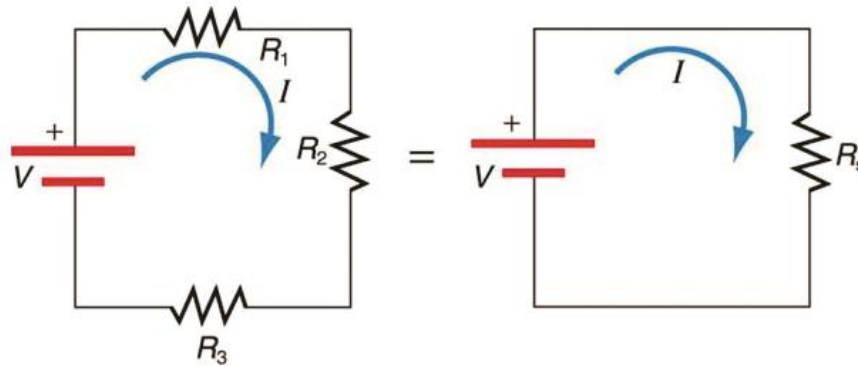
Parallel key idea: Voltage is the same in each resistor by voltage law.

### **Practical Activity: Calculating Resistance, Current, Voltage Drop, and Power Dissipation of a Series Circuit.**

Suppose the voltage output of the battery in *figure 2.12* is 12.0 V, and the resistances are  $R_1 = 1.00 \, \Omega$ ,  $R_2 = 6.00 \, \Omega$ , and  $R_3 = 13.0 \, \Omega$ .

- What is the total resistance?
- Find the current.
- Calculate the voltage drop in each resistor, and show these add to equal the voltage output of the source.
- Calculate the power dissipated by each resistor.
- Find the power output of the source, and show that it equals the total power dissipated by the resistors.





**Fig. 2.12: Series circuits, Courtesy: <http://bit.ly/2LMfKq9>**

Solution for (a)

The total resistance is simply the sum of the individual resistances, as given by this equation:

$$R_s = R_1 + R_2 + R_3 = 1.00 \, \Omega + 6.00 \, \Omega + 13.0 \, \Omega = 20.0 \, \Omega$$

Solution for (b)

The current is found using Ohm's law,  $V = IR$ . Entering the value of the applied voltage and the total resistance yields the current for the circuit:

$$I = V \div R_s = 12.0 \, \text{V} \div 20.0 \, \Omega = 0.60 \, \text{A}$$

Solution for (c)

The voltage or  $IR$  drop in a resistor is given by Ohm's law. Entering the current and the value of the first resistance yields

$$V_1 = IR_1 = (0.600 \, \text{A}) (1.0 \, \Omega) = 0.600 \, \text{V}.$$

Similarly,

$$V_2 = IR_2 = (0.600 \, \text{A}) (6.0 \, \Omega) = 3.60 \, \text{V}$$

And

$$V_3 = IR_3 = (0.600 \, \text{A}) (13.0 \, \Omega) = 7.80 \, \text{V}.$$

Discussion for (c)

The three  $IR$  drops add to 12.0 V, as predicted:

$$V_1 + V_2 + V_3 = (0.600 + 3.60 + 7.80) \, \text{V} = 12.0 \, \text{V}.$$

Strategy and Solution for (d)

The easiest way to calculate power in watts (W) dissipated by a resistor in a DC circuit is to use *Joule's law*,  $P = IV$ , where  $P$  is electric power. In this case, each resistor has the same full current flowing through it. By substituting Ohm's law  $V = IR$  into Joule's law, we get the power dissipated by the first resistor as

$$P_1 = I^2 R_1 = (0.600 \, \text{A})^2 (1.00 \, \Omega) = 0.360 \, \text{W}.$$

Similarly,

$$P_2 = I^2 R_2 = (0.600 \text{ A})^2 (6.00 \ \Omega) = 2.16 \text{ W.}$$

and

$$P_3 = I^2 R_3 = (0.600 \text{ A})^2 (13.0 \ \Omega) = 4.68 \text{ W.}$$

Discussion for (d)

Power can also be calculated using either  $P = IV$  or  $P = V^2/R$ , where  $V$  is the voltage drop across the resistor (not the full voltage of the source). The same values will be obtained.

Solution for (e)

The easiest way to calculate power output of the source is to use  $P = IV$ , where  $V$  is the source voltage. This gives

$$P = (0.600 \text{ A})(12.0 \text{ V}) = 7.20 \text{ W.}$$

Discussion for (e)

Note, coincidentally, that the total power dissipated by the resistors is also 7.20 W, the same as the power put out by the source. That is,

$$P_1 + P_2 + P_3 = (0.360 + 2.16 + 4.68) \text{ W} = 7.20 \text{ W.}$$

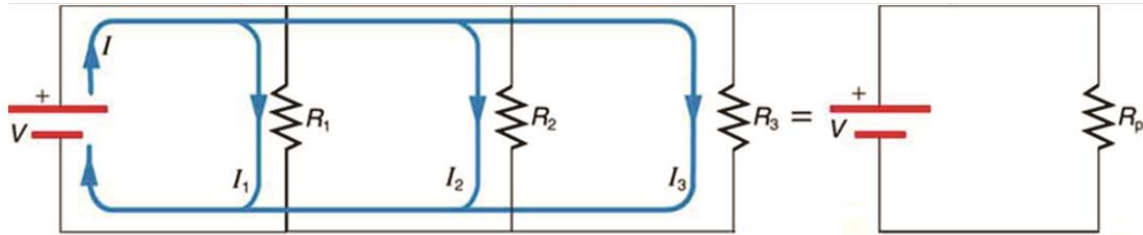
Power is energy per unit time (watts), and so conservation of energy requires the power output of the source to be equal to the total power dissipated by the resistors.

### Major Features of Resistors in Series

1. Series resistances add:  $R_s = R_1 + R_2 + R_3 + \dots$
2. The same current flows through each resistor in series.
3. Individual resistors in series do not get the total source voltage, but divide it.

**Practical Activity:** Calculating Resistance, Current, Power Dissipation, and Power Output: Analysis of a Parallel Circuit.

Let the voltage output of the battery and resistances in the parallel connection in *figure 2.13* are the same as the previously considered series connection:  $V = 12.0 \text{ V}$ ,  $R_1 = 1.00 \ \Omega$ ,  $R_2 = 6.00 \ \Omega$ , and  $R_3 = 13.0 \ \Omega$ . (a) What is the total resistance? (b) Find the total current. (c) Calculate the currents in each resistor, and show these add to equal the total current output of the source. (d) Calculate the power dissipated by each resistor. (e) Find the power output of the source, and show that it equals the total power dissipated by the resistors.



**Fig. 2.13: Parallel Circuit, Courtesy: <http://bit.ly/2LMfKq9>**

Solution for (a)

The total resistance for a parallel combination of resistors is found using the equation below. Entering known values gives

$$\frac{1}{R_p} = \frac{1}{R_1} + \frac{1}{R_2} + \frac{1}{R_3} = \frac{1}{11.00 \, \Omega} + \frac{1}{16.00 \, \Omega} + \frac{1}{113.0 \, \Omega}$$

Thus,

$$\frac{1}{R_p} = 1.00 \, \Omega^{-1} + 0.1667 \, \Omega^{-1} + 0.007692 \, \Omega^{-1} = 1.2436 \, \Omega^{-1}$$

(Note that in these calculations, each intermediate answer is shown with an extra digit.) We must invert this to find the total resistance  $R_p$ . This yields

$$R_p = \frac{1}{1.2436 \, \Omega^{-1}} = 0.8041 \, \Omega$$

The total resistance with the correct number of significant digits is  $R_p = 0.804 \, \Omega$

Discussion for (a)

$R_p$  is, as predicted, less than the smallest individual resistance.

Solution for (b)

The total current can be found from Ohm's law, substituting  $R_p$  for the total resistance. This gives

$$I = \frac{V}{R_p} = \frac{12.0 \, \text{V}}{0.8041 \, \Omega} = 14.92 \, \text{A}$$

Discussion for (b)

Current  $I$  for each device is much larger than for the same devices connected in series (see the previous example). A circuit with parallel connections has a smaller total resistance than the resistors connected in series.

Strategy and Solution for (c)

The individual currents are easily calculated from Ohm's law, since each resistor gets the full voltage. Thus,

$$I_1 = \frac{V}{R_1} = \frac{12.0 \, \text{V}}{1.00 \, \Omega} = 12.0 \, \text{A}$$

Similarly,

$$I_2 = \frac{V}{R_2} = \frac{12.0 \, \text{V}}{6.00 \, \Omega} = 2.00 \, \text{A}$$

and

$$I_3 = \frac{V}{R_3} = \frac{12.0 \, \text{V}}{13.0 \, \Omega} = 0.92 \, \text{A}$$

Discussion for (c)

The total current is the sum of the individual currents:

$$I_1 + I_2 + I_3 = 14.92 \text{ A.}$$

This is consistent with conservation of charge.

Strategy and Solution for (d)

The power dissipated by each resistor can be found using any of the equations relating power to current, voltage, and resistance, since all three are known. Let us use  $P=V^2/R$ , since each resistor gets full voltage. Thus,

$$P_1 = V^2/R_1 = (12.0 \text{ V})^2 / 21.00 \Omega = 144 \text{ W}$$

Similarly,

$$P_2 = V^2/R_2 = (12.0 \text{ V})^2 / 26.00 \Omega = 24.0 \text{ W}$$

and

$$P_3 = V^2/R_3 = (12.0 \text{ V})^2 / 213.0 \Omega = 11.1 \text{ W}$$

Discussion for (d)

The power dissipated by each resistor is considerably higher in parallel than when connected in series to the same voltage source.

Strategy and Solution for (e)

The total power can also be calculated in several ways. Choosing  $P = IV$ , and entering the total current, yields

$$P = IV = (14.92 \text{ A})(12.0 \text{ V}) = 179 \text{ W.}$$

Discussion for (e)

Total power dissipated by the resistors is also 179 W:

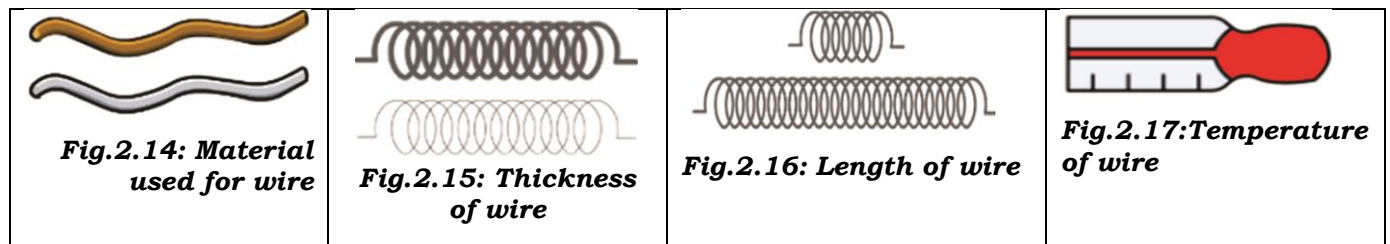
$$P_1 + P_2 + P_3 = 144 \text{ W} + 24.0 \text{ W} + 11.1 \text{ W} = 179 \text{ W.}$$

This is consistent with the law of conservation of energy.

Overall Discussion

Note that both the currents and powers in parallel connections are greater than for the same devices in series.

There are numbers of factors which affects the Resistance value of a wire as discussed below:



|  |  |  |  |
|--|--|--|--|
|  |  |  |  |
|--|--|--|--|

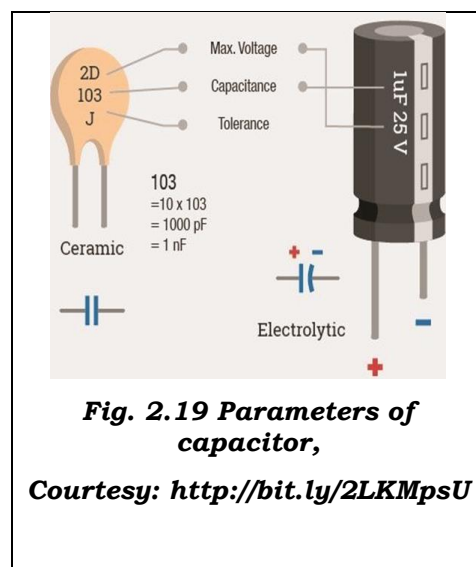
**Practical Assignment:** Calculate the value of equivalent resistance in parallel and series, where value of resistors are  $R_1 = 10$  &  $R_2 = 20$  ohms.

## 2.2 CAPACITOR

The word capacitor specifies the capacity. It represents the capacity to store the energy. In a capacitor, energy is stored in the form of electric field. Capacitor have two parallel sections, between these section energy is stored. It consists of two metallic conducting sections (plates) separated by an insulator (dielectric material) as shown in *figure 2.18*. Metallic conductor can be made up of aluminium, copper, etc. A dielectric can be ceramic, mica, electrolyte, air, paper etc. It store the charges on its metallic plates, this will generate the electric field between the plates. In this way it stores energy in the form of electric field.



Capacitor is one of the fundamental components of electrical and electronic devices. The parameters of capacitor are maximum voltage it can withstand without damage, charge store capacity, polarity of terminals i.e. positive and negative terminals as shown in *figure 2.19*.



Mathematically,

$$Q = C \times V$$

Where,  $Q$  = Charge in coulomb

$C$  = Capacitance in farad

$V$  = Voltage in volt

Smaller unit of capacitance are mili farad (mF), Micro farad ( $\mu$ F), Nano farad (nF), Pico farad (pF).

**For example:** When the 250V is applied across the capacitor of capacitance value  $10 \mu$ F, the amount of charge stored by it is given by:

$$Q = C \times V$$




$$Q = 10 \times 10^{-6} \times 250$$




$$Q = 2.5 \text{ mC}$$

**Practical Assignment: Calculate the following for a capacitor.**

1. Determine the voltage across a 1000 pF capacitor to charge it with 2C.
2. The charge on the plates of a capacitor is 6 mC when the potential between them is 2.4 kV. Determine the capacitance of the capacitor.
3. For how long must a charging current of 2 A be fed to a 5 F capacitor to raise the potential difference between its plates by 500 V. (Hint:  $I=Q/t$ )
4. A direct current of 10 A flows into a previously uncharged 5  $\mu\text{F}$  capacitor for 1 mS. Determine the potential difference between the plates. (Hint:  $I=Q/t$ ).

**Practical Activity:** Identify the different types of capacitors and read its specification mentioned on it.

| Capacitor Picture   | Capacitor Name                       |
|---|--------------------------------------|
|  | <b>Ceramic capacitor</b>             |
|  | <b>Axial electrolytic capacitor</b>  |
|  | <b>Radial electrolytic capacitor</b> |

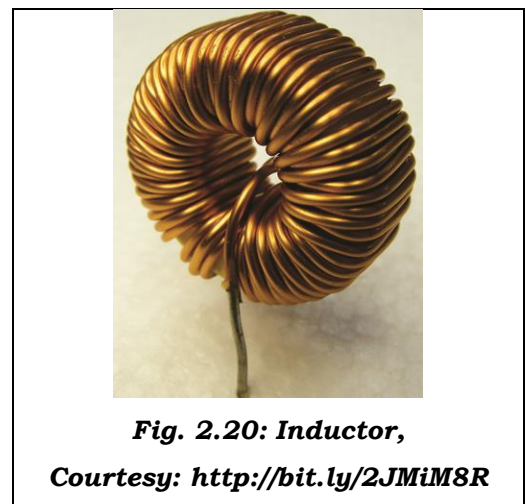
|   |                                      |
|---|--------------------------------------|
|  | <p><b>Paper capacitor</b></p>        |
|  | <p><b>Surface mount resistor</b></p> |
|  | <p><b>Polyester capacitor</b></p>    |

**List the following parameters of capacitors**


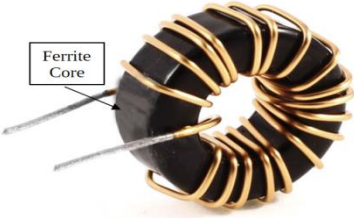

- Operating temperature
- Maximum operating voltage
- Maximum capacitance storage
- Supply type

**2.3 INDUCTOR**

The word *inductor* defines induction. Induction is the process or action of bringing about the rise. In Inductor this rise takes place in the form of energy. Inductor is constructed, when a (conductor) material is wound on the magnetic material. Inductor is like a coil as shown in the *figure 2.20*. When current flows through the coil, magnetic field appears around the wire. This way we can say that inductor stores the energy in the form of magnetic field along the coil. If the current flowing through an inductor changes, a changing magnetic field appears across wires. This changing magnetic field develops



(induces) a voltage across the two ends of the wires. Inductor opposes the change in the electric current passing through it. This property of opposition is known as inductance.

| Inductor Picture   | Name of inductor             |
|--|------------------------------|
|   | <b>Air gap inductor</b>      |
|   | <b>Ferrite core inductor</b> |
|  | <b>SMT inductor</b>          |

## 2.4 SEMICONDUCTOR

Semiconductors are materials whose conductivity is between conductors and insulators. Electronics device are made up of semiconductor material. In semiconductor industry silicon and germanium are widely used. Semiconductors materials are of two types which are as follows:

**2.4.1 Intrinsic (pure)**, it is a pure form of a semiconductor. The pure word here specifies that this semiconductor does not contain any other impurity atom. For example, pure form of silicon contains only the atoms of silicon; no other impurity atom is present in the silicon. Absence of impurity atom result in less conductivity of semiconducting material. To improve the conductivity of intrinsic semiconductor impurity atom has to be added which is discussed in the extrinsic semiconductor.

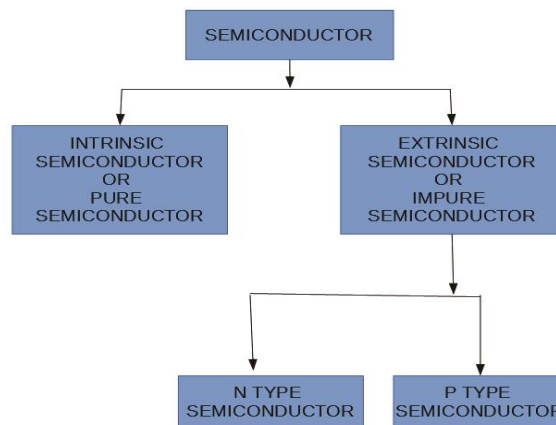
**2.4.2 Extrinsic (impure)**, when impurity atoms are added in the pure (intrinsic) form of semiconductor, then that semiconductor is called as extrinsic



semiconductor. The extrinsic semiconductors are also known as impure semiconductor. Extrinsic semiconductors are classified as N-type and P-type semiconductor. For example, presence of impurity atoms (ex. Arsenic (As)) in the pure silicon semiconductor. Process of adding of an impurity atom in a semiconductor is called as doping. Doping will increase the conductivity of a semiconductor.

Since, the atomic number of silicon is 14; electronic configuration of silicon is 2, 8, and 4. Thus, silicon has 4 electrons in the outer most shell. In order to increase the conductivity more and more free carriers has to added. As silicon has 4 electrons in its outermost shell, so it is better to add an impurity atom having valence (number of atoms in outermost shell) either 5 (penta) or 3 (tri). The atoms which have 5 electrons in its outermost shell are known as pentavalent. The atoms which have 3 electrons in its outermost shell are known as trivalent.

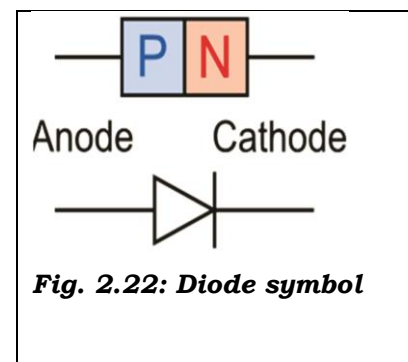
- When pentavalent impurity atom is added an extrinsic semiconductor is formed which is known as **N-type semiconductor**.
- When trivalent impurity atom is added an extrinsic semiconductor is formed which is known as **P-type semiconductor**.



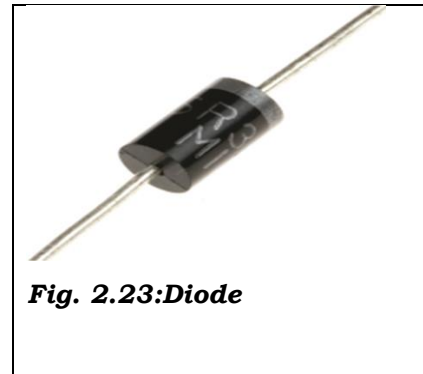
**Fig. 2.21: Classification of semiconductor**

## 2.5 DIODE

When two semiconductors i.e. P-type semiconductor and N-type semiconductor are combined to form new component which is known as **diode**. “Di” defines two, thus diode have two terminals as shown in *figure 2.22, figure 2.23, figure 2.24*.

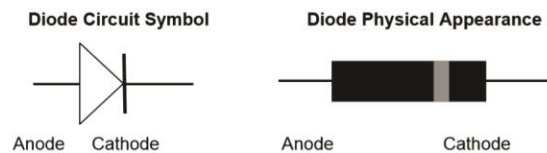


Diode can be used in switching application. Diode passes current only in one direction. The P-side is called anode and the N-side is called cathode. When the anode and cathode of a PN-junction diode are connected to external voltage source such that the positive end of a battery is connected to the anode and negative end of the battery is connected to the cathode, diode is said to be **forward biased** or we can say that diode will acts as a close switch (it will turned “ON”). In a forward-biased condition, diode will pass the current through it.



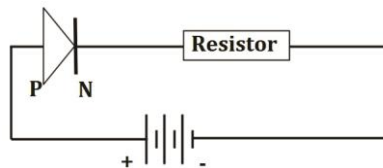
**Fig. 2.23:Diode**

When the P-side of diode are connected to the negative terminal of the battery and N-side of the diode is connected to positive terminal of the battery, diode is said to be **reverse biased** or we can say that diode will acts as an open switch (it will turned “OFF”). In reverse-biased condition, diode will not pass the current through it.



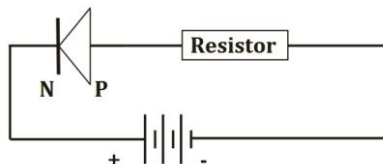
**Fig. 2.24: Terminals of diode**

If the anode of PN diode is connected to the positive terminal of battery and cathode of diode is connected to the negative terminal of battery, in this case diode is said to be in forward bias and current will flow through the diode.



**Fig. 2.25: In this circuit current will flow**

If the anode of PN diode is connected to the negative terminal of battery and cathode of diode is connected to the positive terminal of battery, in this case diode is said to be in reverse bias and current will not flow through the diode.



**Fig.2.26: In this circuit current will not flow**

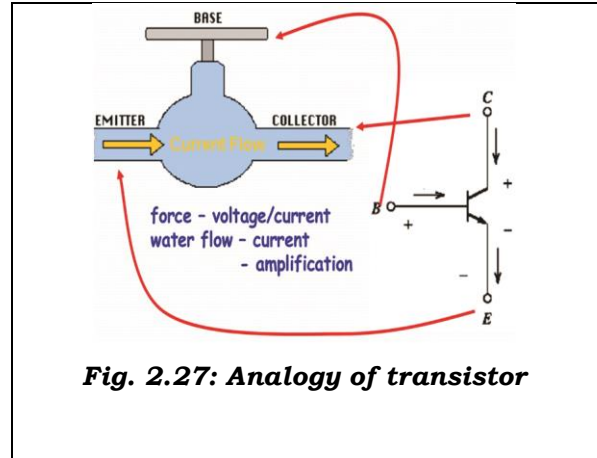
## 2.6 TRANSISTOR

Transistor is a three layer semiconducting device. These three layers have three terminals emitter, base, and collector respectively. It has two junctions, where

the two layers touch each other is called as **junction**. The junction where emitter layer and base layer touch each other is named as **emitter base junction**. The junction where collector layer and base layer touch each other is named as **collector base junction**.

Transistor will act as switch or can be used for amplification. An easy way to understand transistor is that it is a switch which is controlled by an electrical signal. Transistor can also be used for enhancing the applied signal strength.

To understand the functioning of a transistor, we can relate it with the water supply system in our home. Storage tank which is kept at the roof of the building is similar to emitter in transistor which acts as source of charge carrier (i.e. electrons and holes in semiconductor). The tap at the ground is similar to the base of transistor; this tap controls the flow of water likewise base control the flow of charge carrier. Bucket at the ground collect the water coming from the storage tank likewise collector of transistor collects the charge carriers coming from emitter. There are two junction in the transistor i.e. emitter-base junction and collector-base junction.



**Fig. 2.27: Analogy of transistor**

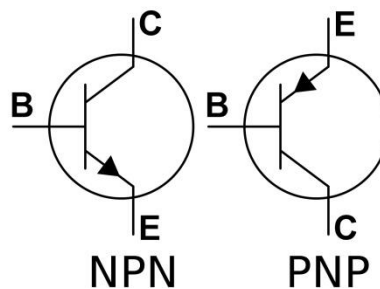
### Identifying BJT Terminals:

Keep the transistor such that the flat surface facing towards you as shown in the below figure:

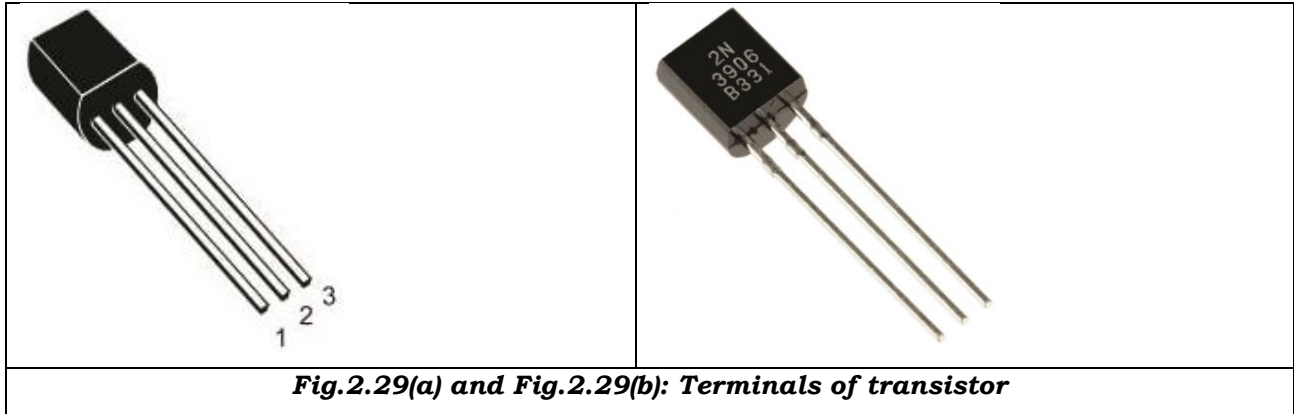
We know that the bipolar junction transistor has three terminals namely

1. Emitter (E)
2. Base (B)
3. Collector(C)

The schematic symbol of the BJT is given below:



**Fig.2.28 BJT symbol**



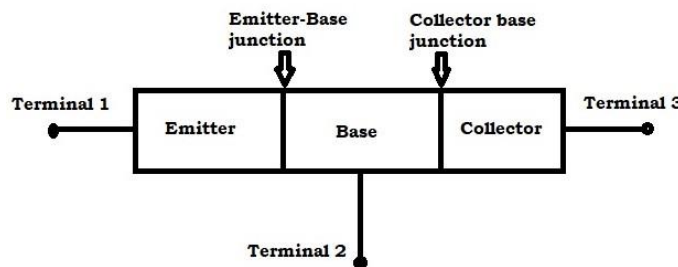
**Fig.2.29(a) and Fig.2.29(b): Terminals of transistor**

**Practical Activity: Identification of Bipolar junction transistor terminal using multimeter.**

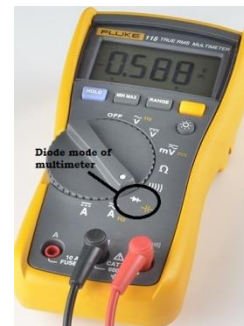
NPN and PNP are the two types of BJT. Both are similar in physical appearance. Physically, they cannot be differentiated. Multimeter is use to identify the type of BJT.

Following points illustrate the steps for the identification of BJT types:

- If we see transistor internally, BJT has two junctions (NPN  $\equiv$  N - P - N  $\equiv$  NP Junction + PN Junction and PNP  $\equiv$  P - N - P  $\equiv$  PN Junction + NP Junction).
- Emitter to base is one PN junction (diode) and Base to collector another PN junction (diode).

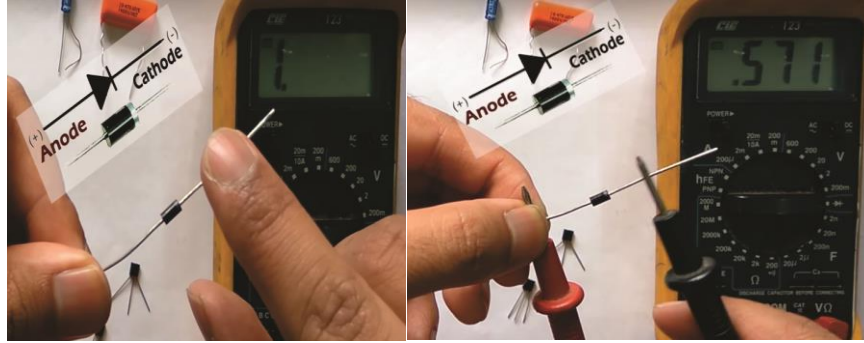


**Fig. 2.30 (a)**



**Fig. 2.31(b)**

- When multimeter is set to diode mode, then the multimeter will show the voltage when we keep the positive probe of the multimeter to the anode of the diode and negative probe to the cathode.



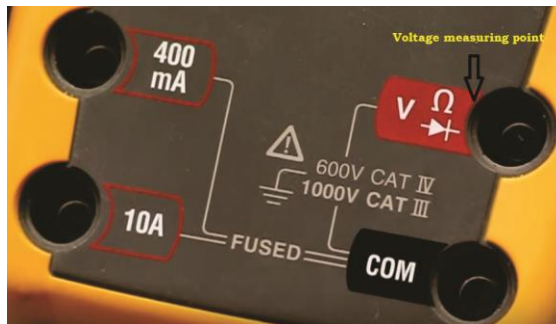
**Fig.2.32(a)**

**Fig.2.32(b)**

- When multimeter is set to diode mode, then the multimeter will not show the voltage. When we keep the positive probe of the multimeter to the anode of the diode and negative probe to the cathode.

**Steps to identify the NPN type transistor:**

- a) Connect the red cord to the voltage measuring point.



**Fig.2.33**

- b) Connect the black cord to the common point.



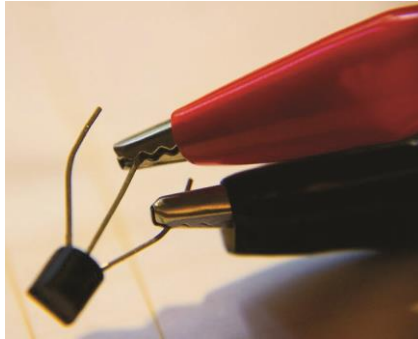
**Fig.2.34**

c) Turn the multimeter in the diode mode.

d) Touch the red probe to the centre pin (Base) of the transistor, black probe to the either of the two pin-1 (Emitter) or pin- 3 (collector) of BJT.



**Fig.2.35**



**Fig.2.36**

e) Look at the display of multimeter.

f) It will NPN transistor. The logic behind this is, in NPN transistor.

- Emitter (E) – N type material – Equivalent to cathode of the diode
- Base (B) – P type material – Equivalent to anode of the diode
- Collector (C) – N type material – Equivalent to cathode of the diode

g) If the multimeter positive probe is connected to anode and negative probe is connected to cathode, then it will show voltage. If the connections are interchanged it will not show any value.



**Fig.2.37**

### Steps to identify the PNP type transistor:

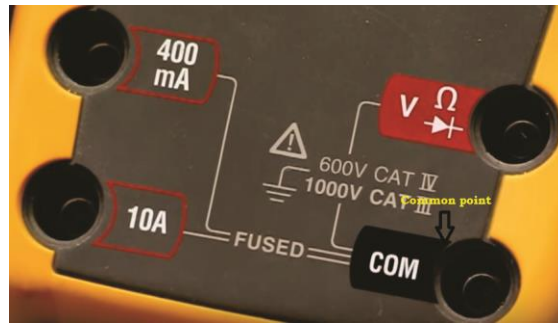
a) Connect the red cord to the voltage measuring point.



**Fig. 2.38**



b) Connect the black cord to the common point.



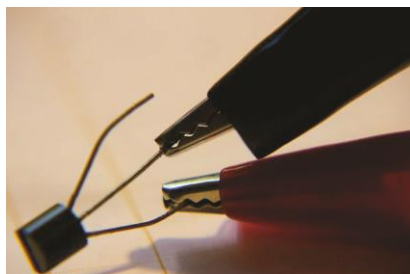
**Fig. 2.39**

c) Turn the multimeter in the diode mode.



**Fig. 2.40**

d) Touch the black probe to the centre pin (Base) of the transistor, red probe to the either of the two pin – 1 (Emitter) or pin- 3 (collector) of BJT.



**Fig. 2.41**

e) Look at the display of multimeter.

f) It will be PNP transistor. The logic behind this is, in PNP transistor.

- Emitter (E) – P type material – Equivalent to anode of the diode,
- Base (B) – N type material – Equivalent to cathode of the diode,

- Collector (C) – P type material – Equivalent to anode of the diode.

g) If the multimeter positive probe is connected to anode and negative probe is connected to cathode, then it will show voltage. If the connections are interchanged it will not show any value.



**Fig. 2.42**

**More to know:**

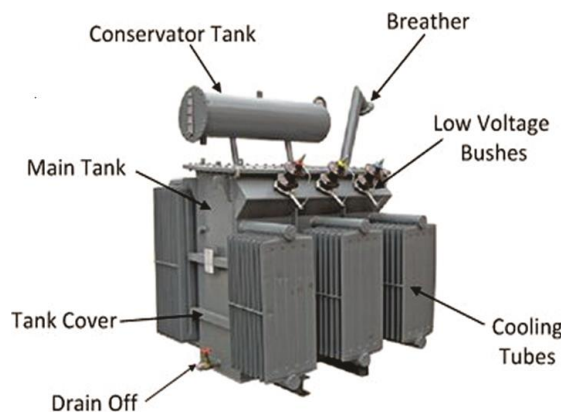
**Switch** is a device which has two operations i.e. ON and OFF. When switch is closed (ON) current flows in the circuit. In this case circuit is said to be complete. When switch is open (OFF), current will not flow in the circuit. In this case circuit is said to be incomplete.

**Amplification** is the process of increasing the level of voltage and current. Transistor is used in such a way that it will increase the voltage and current level of the input signal which is given to the transistor.

Transistors have three terminals. In transistors major current flows between any two terminals while third terminal is used for controlling the flow of current between terminals.

**2.7 TRANSFORMER**

A transformer is a static unit. It simply transforms the voltage level of an AC signal. It either step-up or step down the AC voltage. It works on the principle of electromagnetic induction. Transformer does not change the frequency of applied AC signal. Transformers play an important role in the electrical systems.



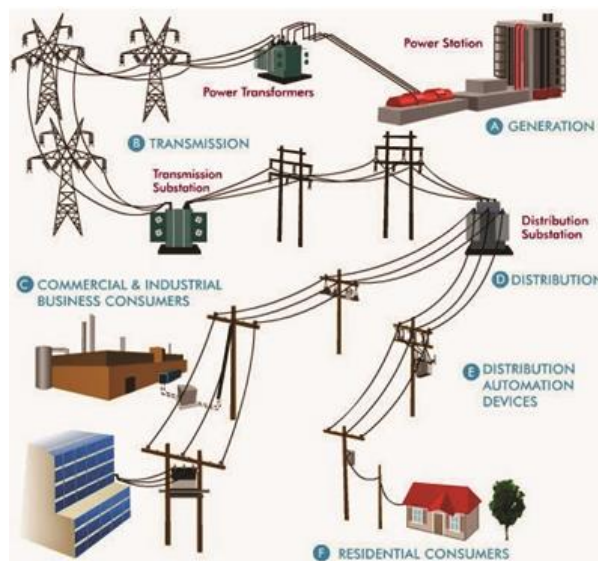
**Fig. 2.43: Transformer Parts**



1. Transformers are available in number of sizes, for example transformer used in mobile charger is very small, whereas transformers used in substation of an electricity board are bulk or big.
2. High voltage is used for transmission and low voltage is used in office and home.
3. Transformers are used to increase or decrease AC voltage in transmission and distribution of electricity.
4. Basic construction of transformer includes two coil, wind on the magnetic frame or core.
5. Both the coils are magnetically coupled, whereas they are electrically insulated from each other.
6. The primary or input coil is connected to the energy source, while secondary or output coil supplies power to load.
7. Electromagnetic induction is used in a transformer. In power grids large transformers are used. These transformers are used in the generation, distribution, transmission system of electrical system. Transformer is present in every location from the generator and to the user.






**Fig. 2.44: Input output terminals of transformer**

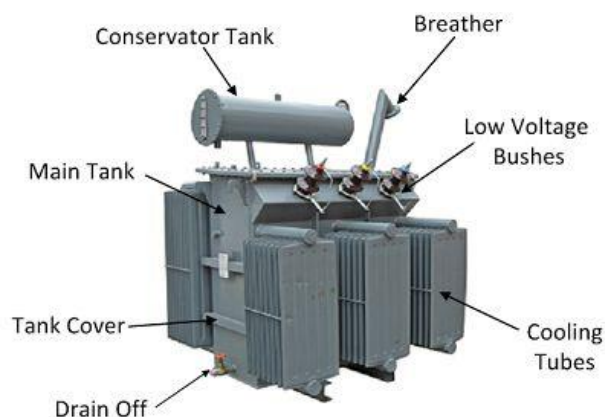


**Fig. 2.45: Electrical network, Courtesy: <http://bit.ly/2OdX1Cs>**

**Practical activity:** Identify different types of transformer and read the specification mentioned on the transformer.

| Transformer  | Name of transformer                 | Specification mentioned on the transformer                |
|--|-------------------------------------|---|
|   | <b>Simple step-down transformer</b> | Input voltage:<br>Output voltage:<br>Operating Frequency: |
|   | <b>Centre-tape transformer</b>      | Input voltage:<br>Output voltage:<br>Operating Frequency: |
|  | <b>High frequency transformer</b>   | Input voltage:<br>Output voltage:<br>Operating Frequency: |

**Practical Activity:** Visit the nearest power distributing substation and identify and name the different parts of high voltage transformer as shown in figure below.



**Practical activity:** Perform an experiment to identify the primary and secondary winding of transformer.

**Material Required:** Transformer (230V to 12V), multimeter, input supply, Bulb of 200 watt, wire, wire stripper, wire cutter, insulation tape.

**Circuit diagram:**

Fig.

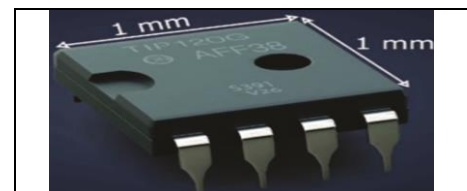
**Procedure:**

- a) Connect the wire to the primary winding of the transformer.
- b) Connect the wire to the secondary winding of the transformer.
- c) Connect the primary winding wire to the input supply carefully.
- d) Connect the wire of secondary winding to the load.
- e) Turn ON the power supply.
- f) Measure the voltage using multimeter at primary and secondary winding.
- g) Note down the reading displayed on the screen of multimeter.
- h) Note the observed reading in the following table:

| S.No. | Reading at primary winding | Reading at secondary Winding |
|-------|----------------------------|------------------------------|
| 1.    |                            |                              |
| 2.    |                            |                              |
| 3.    |                            |                              |
| 4.    |                            |                              |
| 5.    |                            |                              |

## 2.8 INTEGRATED CIRCUIT (IC)

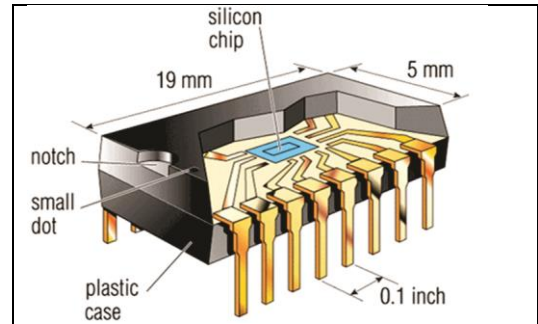
An integrated circuit is a combination of electronic components on single piece (or "chip") of semiconductor material as shown in *figure 2.46*. Integrated circuit has large numbers of tiny transistors into a small chip and results in circuits that are smaller, cheaper, and faster.



**Fig. 2.46: Integrated Circuit**

Integrated circuit has number of pins. Each pin defines an input or output. Datasheet is required when working with an integrated circuit chip. Datasheet give complete information about a particular integrated circuit.

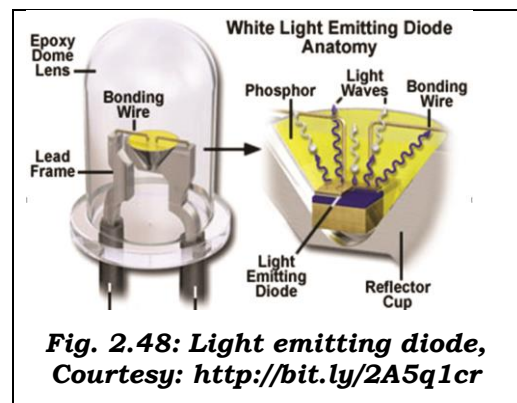
The internal structure of IC is shown in *figure 2.47*.



**Fig. 2.47: Internal structure of IC,**  
**Courtesy: <http://bit.ly/2NFMD5b>**

## 2.9 LIGHT EMITTING DIODE

Light-Emitting Diode (LEDs) comprises of several layers of semi-conducting material. When the diode is being utilized with DC, the active layer produces light. The LED emits light in a particular colour and this colour is dependent on the type of semiconductor material used in it. LEDs are made of semiconductor crystals as shown in *figure 2.48*.



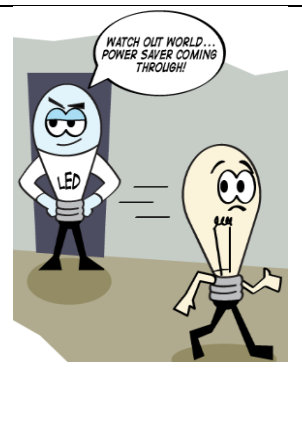
**Fig. 2.48: Light emitting diode,**  
**Courtesy: <http://bit.ly/2A5q1cr>**

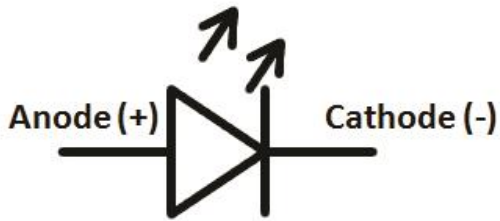
When current flows through them, they emit light in red, green, yellow, or blue colours depending on the composition of the crystal compounds. Blue LEDs also emit white light by using a yellowish fluorescent layer or by creating a mix of red, green, and blue (RGB) LEDs.

### Powerful fact:

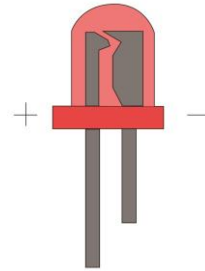
Why LEDs are good choice?

1. Long life
2. Durable
3. High efficiency
4. Low energy use
5. Compact size
6. No UV issue





**Fig. 2.49: LED Symbol,**  
**Courtesy: <http://bit.ly/2A7KYnc>**



**Fig. 2.50: LED Light,** **Courtesy:**  
**<http://bit.ly/2LzWkuU>**

### CHECK YOUR PROGRESS

#### A. Choose the correct option from those given below

1. A diode \_\_\_\_\_
  - a) Is the simplest of semiconductor devices
  - b) Has characteristics that closely match those of a simple switch
  - c) Is a two-terminal device.
  - d) All of the above
2. Which of the following is a semiconductors material?
  - a) Silicon
  - b) Germanium
  - c) Both A and B
  - d) None of these
3. A LED produces light when
  - a) Forward biased.
  - b) Reverse biased.
  - c) Unbiased.
  - d) None of the above.
4. Two terminals semiconductor device is
  - a) Diode
  - b) Triode
  - c) Transistor
  - d) Integrated circuit

5. Resistance of variable resistors can be changed and hence they are called
  - a) Rheostat
  - b) Fixed Resistor
  - c) Variable Resistor
6. ....consist of a coil or a wire loop.
  - a) Inductor
  - b) Capacitor
  - c) Resistor
  - d) Diode
7. Three terminals semiconductor device is
  - a) Diode
  - b) Transistor
  - c) IC
  - d) All of the above
8. Different colour emitted by LED is because of -
  - a) Applied Voltage
  - b) Due To Forward Or Reverse Bias
  - c) Due To Different Compounds Formation
  - d) None of these
9. LED requires..... supply.
  - a) AC
  - b) DC
  - c) AC or DC
  - d) None of these
10. Transformer is used to
  - a) Step up the voltage
  - b) Step down the voltage
  - c) Both A and B
  - d) None Of These
11. Transformer works on
  - a) AC
  - b) DC

- c) both AC and DC
  - d) None of these
12. Transistor has ..... layers and .....junctions.
- a) Two, Three
  - b) Three, Two
  - c) Three, Three
  - d) Two, Two
13. Diode is forward biased when.....
- a) Cathode is connected to positive and anode is connected to negative terminal of battery
  - b) Cathode is connected to negative and anode is connected to positive terminal of battery
  - c) No specific polarity is required
  - d) None of these
14. Diode is reverse biased when.....
- a) Cathode is connected to positive and anode is connected to negative terminal of battery.
  - b) Cathode is connected to negative and anode is connected to positive terminal of battery.
  - c) No specific polarity is required.
  - d) None of these
15. Device which store energy in the form of electric field.
- a) Capacitor
  - b) Inductor
  - c) Resistors
  - d) Diode
16. Device which store energy in the form of magnetic field.
- a) Capacitor
  - b) Inductor
  - c) Resistors
  - d) Diode
17. Resistance of material is affected
- a) Length

- b) Temperature
- c) Thickness
- d) All Of These

18. Pentavalent impurities in extrinsic semiconductor have ..... electrons in its outermost orbit.

- a) 3
- b) 5
- c) 4
- d) 2

19. Trivalent impurities in extrinsic semiconductor have ..... electrons in its outermost orbit.

- a) 3
- b) 5
- c) 4
- d) 2

20. Pure form of semiconductor is called as.....

- a) Intrinsic semiconductors
- b) Extrinsic semiconductors
- c) both A and B
- d) None of these

21. Impure form of semiconductor is called as.....

- a) Intrinsic semiconductors
- b) Extrinsic semiconductors
- c) both A and B
- d) None of these

22. What are the two major categories for resistors?

- a) Low and high power value
- b) Commercial and industrial
- c) Low and high ohmic value
- d) Fixed and variable

23. What is the ohmic value for the colour code of orange, orange, orange?

- a) 22 k  $\Omega$
- b) 33 k  $\Omega$



- c) 3300  $\Omega$
- d) 44000  $\Omega$

24. Which of the following is true for resistance?

- a) symbolized by R, measured in ohms, and directly proportional to conductance
- b) represented by the flow of fluid in the fluid circuit
- c) directly proportional to current and voltage
- d) the opposition to current flow accompanied by the dissipation of heat

25. Resistor tolerance is either printed on the component, or is provided by:

- a) company
- b) keyed containers
- c) colour code
- d) size

26. For a fixed voltage if resistance decreases, then current will:

- a) decrease
- b) double
- c) increase
- d) remain the same

27. Resistance in a circuit is:

- a) The same as current
- b) Opposition to current
- c) The same as voltage
- d) Opposition to voltage

28. A colour code of Brown, Brown, Red, Gold is for what ohmic value?

- a) 1.2k  $\Omega$  5%
- b) 1.1k  $\Omega$  5%
- c) 1.3k  $\Omega$  5%
- d) 1.5k  $\Omega$  5%

29. A colour code of Black, Brown, green, Gold is for what ohmic value?

- a)  $1 \times 10^5 \Omega$  5%
- b)  $1 \times 10^4 \Omega$  5%
- c)  $1 \times 10^5 \Omega$  10%

d)  $1 \times 10^4 \Omega$  10%

30. A colour code of Brown, Red, orange, silver is for what ohmic value?

a)  $12 \times 10^3 \Omega$  10%

b)  $21 \times 10^3 \Omega$  10%

c)  $14 \times 10^3 \Omega$  5%

d)  $12 \times 10^2 \Omega$  5%

31. A colour code of Red, yellow, grey, Gold is for what ohmic value?

a)  $23 \times 10^8 \Omega$  5%

b)  $24 \times 10^8 \Omega$  5%

c)  $25 \times 10^7 \Omega$  5%

d)  $22 \times 10^7 \Omega$  5%

**B. Fill in the blanks with correct word**

a) Transformer work on..... voltage

b) Extrinsic semiconductor is ..... form of semiconductor.

c) Intrinsic semiconductor is ..... form of semiconductor.

d) Capacitor stores energy in the form of ..... field.

e) Inductor stores energy in the form of ..... field.

f) Diode has..... terminals.

g) Silicon is..... material.

h) Transistor has ..... terminals.

i) When LED is forward biased it will turn.....

j) A three terminals semiconducting device is.....

**C. State whether the statement given below are true or false.**

a) Transformer is used to step up the voltage.

b) LED emits light in a particular colour and this colour is dependent on the type of semiconductor material used in it.

c) Transistor is used as an amplifier and switch.

d) The electromagnetism in a transformer is the energy source for the transformer.

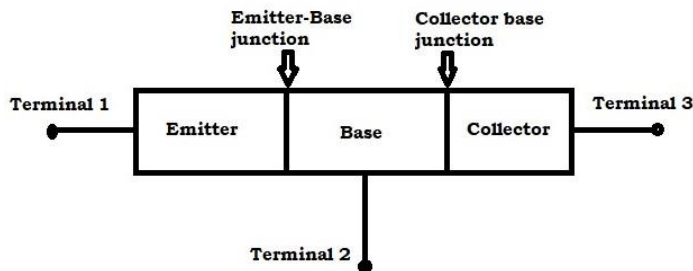
e) Low voltage is used for transmission and High voltage is used in office and home.

f) Transformer changes the frequency of the applied signal.

- g) The junction where emitter layer and base layer touch each other is named as emitter base junction.
- h) Amplification is the process of increasing the level of voltage and current.
- i) The base unit of capacitance is the farad.
- j) Green, Orange, Orange, Violet colour coded resistor is  $62\text{k}\Omega$  5%.
- k) Violet, Green, Orange, Silver colour coded resistor is  $75\text{k}\Omega$  10%.
- l) Blue, Red, Orange, Gold colour coded resistor is  $62\text{k}\Omega$  5%.
- m) Orange, Orange, Yellow, Gold colour coded resistor is  $330\text{k}\Omega$  5%.
- n) Red, Orange, Yellow, Gold colour coded resistor is  $330\text{k}\Omega$  5%.
- o) Black, Red, green, Silver colour coded resistor is  $300\text{k}\Omega$  5%.
- p) Brown, green, orange, Silver colour coded resistor is  $15\text{k}\Omega$  10%.
- q) Orange, Orange, Yellow, Gold colour coded resistor is  $330\text{k}\Omega$  5%.
- r) Orange, Orange, Yellow, Gold colour coded resistor is  $330\text{k}\Omega$  5%.
- s) Semiconductors are materials whose conductivity lie between conductors and insulators.
- t) Inductor store energy in the form of electric field.

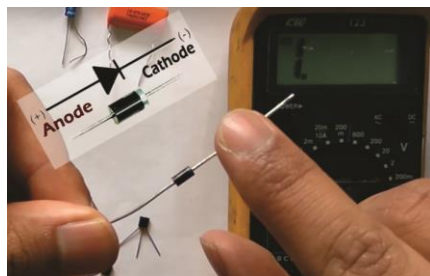
**D. Short answer type question**

- a) Write short notes on : Diode, Transistor, LED, Capacitor, Inductor
- b) Calculate the total resistance of the circuit in *figure 2.30*.



**Fig. 2.30**

- c) Calculate the total resistance of the figure 2.31.



**Fig. 2.31**

- d) What is an extrinsic semiconductor?
- e) What is an intrinsic semiconductor?
- f) What are the applications of transistor?
- g) Write down the specification of capacitor.
- h) Why LEDs are good choice?
- i) What is an inductance?
- j) What is a capacitor?

**B. Fill in the blanks by calculating the value of colour code**

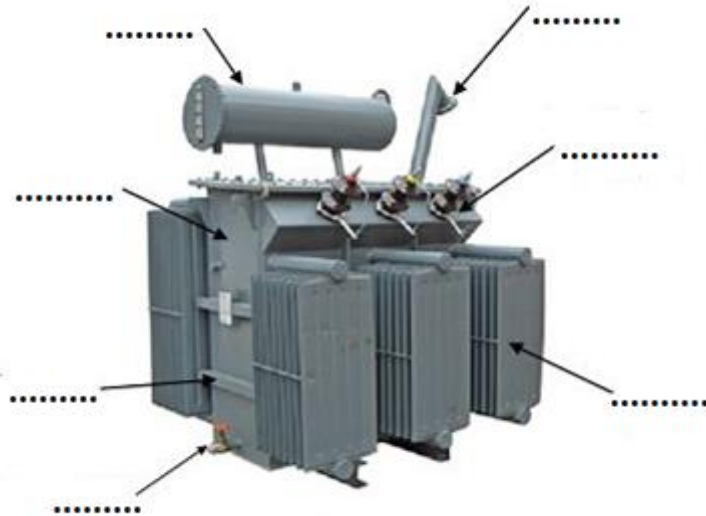
- a) Red, Brown, Red, and Silver colour coded resistor has value.....
- b) Orange, Yellow, Red, and Silver colour coded resistor has value.....
- c) Blue, Yellow, Orange, Gold colour coded resistor has value.....
- d) Violet, Green, Orange, and Silver colour coded resistor has value.....
- e) Grey, Red, Yellow, and Gold colour coded resistor has value resistor has value.....
- f) Red, Red, Yellow, and Gold colour coded resistor has value has value .....
- g) Blue, Red, Orange, and Gold colour coded resistor has value.....
- h) Green, Orange, Orange, and Violet colour coded resistor has value .....
- i) Red, brown, Yellow, Green colour coded resistor has value.....
- j) Brown, brown, Yellow, Green colour coded resistor has value is.....

**D. Find the value of resistance for the following.**

1. A resistor has a colour band sequence: yellow, violet, orange and gold.
2. A resistor has a colour band sequence: red, red, orange and silver.
3. A resistor has a colour band sequence: orange, red, green and gold.
4. A resistor has a colour band sequence: orange, orange, black and gold.
5. A resistor has a colour band sequence: red, green, orange and gold.
6. A resistor has a colour band sequence: orange, red, green, red and gold.
7. A resistor has a colour band sequence: red, red, green, black and gold.
8. A resistor has a colour band sequence: red, red, black, red and gold.
9. A resistor has a colour band sequence: brown, red, yellow, red and gold.
10. Find the resistance value of the resistor whose code is

- a) 1252A
- b) 1131C
- c) 1452D

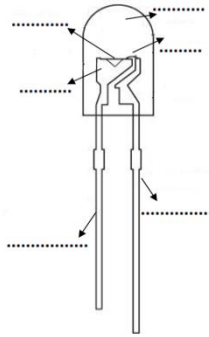
**Practical Exercise:** Identify and name the parts of transformer in the figure below.




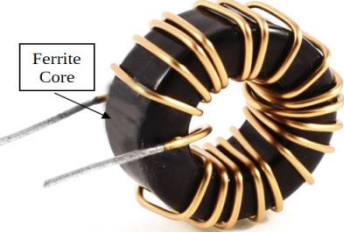

**Practical Exercise:** Identify and name the P type and N type terminal of diode in the following figure below. Also specify the anode and cathode terminals of diode.



**Practical Exercise:** Identify the parts of Light Emitting Diode (LED) in the above figure.



**Practical Exercise:** Identify and name different types of inductor listed in the following table.

| Types of inductor   | Name of inductor |
|---|------------------|
|   |                  |
|  |                  |
|  |                  |

**Match the column**

| <b>Name of components</b> | <b>Related terms</b>              |
|---------------------------|-----------------------------------|
| Semiconductor             | Magnetic field                    |
| Capacitor                 | Opposition in the flow of current |
| Resistor                  | Unidirectional device             |
| Inductor                  | Electric field                    |
| diode                     | Three terminal device             |
| Transistor                | Trivalent and pentavalent         |

## Chapter 3

# TOOLS AND EQUIPMENT

### INTRODUCTION

Electrical quantities such as voltage, current, resistance and other quantities can be accurately measured with instruments called *meters*. Although we cannot see electricity, the meter is designed to react to these electrical quantities and we can read this reaction on the calibrated scale of meters. A meter is a measuring instrument. An ammeter measures current, a voltmeter measures the potential difference (voltage) between two points, and an ohmmeter measures resistance. A multimeter combines these functions and possibly some additional ones as well, into a single instrument. Various tools and equipments are used for the installation of the equipments in the control panel such as screwdriver, phase tester, stripper, plier etc. These basic tools and equipments are discussed in the following session.

### 3.1 MULTIMETER

Multimeters are very useful test instruments. By operating a multi-position switch on the meter they can be quickly and easily set to be a voltmeter, an ammeter or an ohmmeter. They have several settings (called 'ranges') for each type of meter and the choice of AC or DC. Some multimeters have additional features such as transistor testing and ranges for measuring capacitance and frequency. Multimeters are available in digital and analogue types.

**Practical activity:** Use multi-meter to measure the various electrical quantity.

**Apparatus required:** Digital Multimeter, resistor, AC and DC power source, connecting cords.

#### a) Measuring the resistance using digital multimeter.

##### Procedure:

1. Digital multimeter has two probes. Using these probes measurement of resistance can be done. Insert the black probe into the common terminal and the red probe into the terminal marked for measuring volts and ohms. The terminal may also be marked for testing diodes



Fig 3.1



- Twist the selector knob to set the multimeter to measure resistance. This may be represented by the Greek letter Omega, which stands for ohms, the unit of measurement for resistance.



Fig.3.2

Image source: <http://bit.ly/2OLIK00>

- Touch the tips of the probes to each side of the resistor.

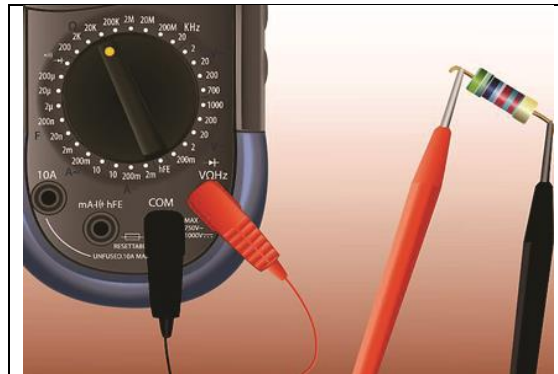


Fig.3.3

Image source: <http://bit.ly/2OLIK00>

- Read the display, taking care to note the units. A reading of 10 may indicate 10 ohms, 10 kilo-ohms or 10 mega-ohms.



Fig.3.4

Image source: <http://bit.ly/2OLIK00>

## b) Measuring AC and DC voltage using digital multimeter.

### Procedure:

1. Digital multimeter has two probes. Using these probes measurement of resistance can be done. Put the black probe in the common terminal and the red probe in the terminal marked for measuring volts and ohms.



Fig.3.5

Image source: <http://bit.ly/2OLIK00>

2. Set the multimeter for the voltage you are measuring. You can measure volts DC (direct current), millivolts DC or volts AC (alternating current). If your multimeter has an auto-range function, it is not necessary to select the voltage you are measuring.



Fig.3.6

Image source: <http://bit.ly/2OLIK00>

3. Measure AC voltage by placing the probes across the component. In case of AC it is not necessary to observe polarity.



Fig.3.7

Image source: <http://bit.ly/2OLIK00>

4. Observe polarity when measuring DC voltage or millivoltage. Place the black probe on the negative side of the DC source and the red probe on the positive side of the DC source.



Fig.3.8

Image source: <http://bit.ly/2OLIK00>



4. Break the circuit. To measure current, you must place the multimeter in series with the circuit. Place the probes on either side of the break, observing polarity (black probe on negative side, red probe on positive side.)

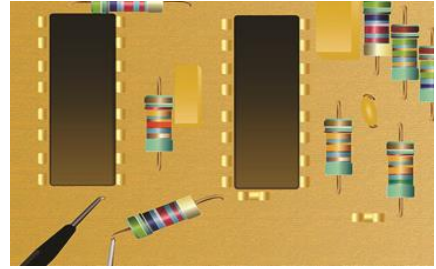


Fig.3.13

Image source: <http://bit.ly/2OLIK00>

5. Turn the power on. The current will run through the circuit, up the red probe and through the multimeter, then out the black probe and into the circuit.



Fig.3.14

Image source: <http://bit.ly/2OLIK00>

6. Read the display, remembering whether you are measuring amps or milliamps. You can use the touch-hold feature if required.



Fig.3.15

Image source: <http://bit.ly/2OLIK00>

**Practical Activity:** Identification of Bipolar junction transistor terminal using multimeter.

**Apparatus required:** Multimeter, NPN transistor, PNP transistor, connecting cords.

**Procedure:** NPN and PNP are the two types of BJT. Both are similar in physical appearance. Physically, they cannot be differentiated. Multimeter is use to identify the type of BJT.

Following points illustrate the steps for the identification of BJT types:

- If we see transistor internally, BJT has two junctions (NPN  $\equiv$  N - P - N  $\equiv$  NP Junction + PN Junction and PNP  $\equiv$  P - N - P  $\equiv$  PN Junction + NP Junction).
- Emitter to base is one PN junction (diode) and Base to collector another PN junction (diode).
- When multimeter is set to diode mode, then the multimeter will show the voltage when we keep the positive probe of the multimeter to the anode of the diode and negative probe to the cathode.
- When multimeter is set to diode mode, then the multimeter will not show the voltage. When we keep the positive probe of the multimeter to the anode of the diode and negative probe to the cathode.

**Steps to identify the NPN type transistor:**

1. Connect the red cord to the voltage measuring point.
2. Connect the black cord to the common point.
3. Turn the multimeter in the diode mode.
4. Touch the red probe to the centre pin (Base) of the transistor, black probe to the either of the two pin-1 (Emitter) or pin- 3 (collector) of BJT.
5. Look at the display of multimeter.
6. It will NPN transistor. The logic behind this is, in NPN transistor.
  - Emitter (E) - N type material - Equivalent to cathode of the diode
  - Base (B) - P type material - Equivalent to anode of the diode
  - Collector(C) - N type material - Equivalent to cathode of the diode
7. If the multimeter positive probe is connected to anode and negative probe is connected to cathode, then it will show voltage. If the connections are interchanged it will not show any value.

**Steps to identify the PNP type transistor:**

1. Connect the red cord to the voltage measuring point.
2. Connect the black cord to the common point.
3. Turn the multimeter in the diode mode.
4. Touch the black probe to the centre pin (Base) of the transistor, red probe to the either of the two pin – 1 (Emitter) or pin- 3 (collector) of BJT.
5. Look at the display of multimeter.
6. It will be PNP transistor. The logic behind this is, in PNP transistor.
  - Emitter (E) - P type material - Equivalent to anode of the diode

- Base (B) - N type material - Equivalent to cathode of the diode
- Collector(C) - P type material - Equivalent to anode of the diode

7. If the multimeter positive probe is connected to anode and negative probe is connected to cathode, then it will show voltage. If the connections are interchanged it will not show any value.

**Practical activity:** To study and verify the functionality of diode.

**Apparatus required:** Diode, Resistor, Breadboard, Digital multimeter as a Voltmeter, Digital multimeter as a Ammeter, DC Power Supply, Connecting wires.

**Circuit diagram:**

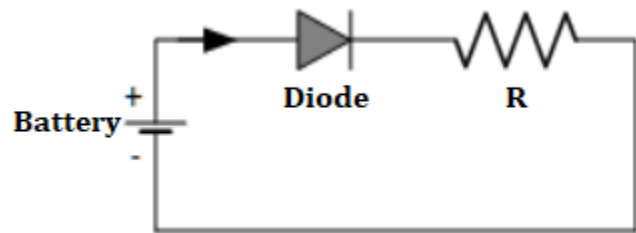


Fig.3.16 Diode is in forward bias mode

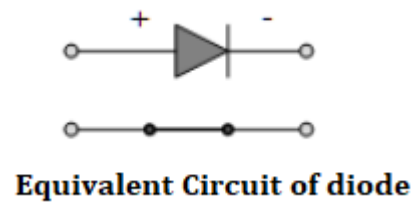


Fig.3.17 Diode in forward bias acts as a close switch

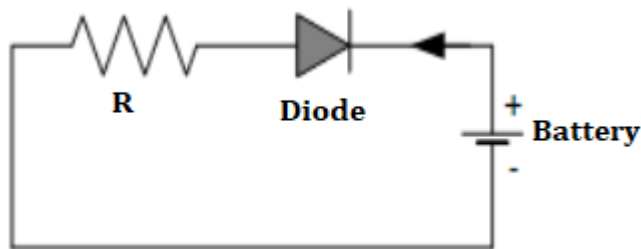


Fig.3.18 Diode is in reverse bias mode

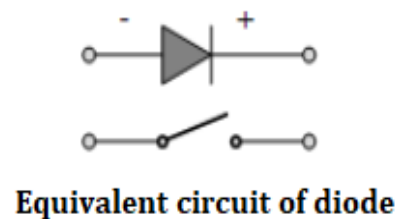


Fig.3.19 Diode in reverse bias acts as an open switch

**Procedure:**

(a) Forward Bias Condition:

1. Connect the circuit as shown in Fig.1 (PN Junction diode with milli-ammeter in series with the diode).
2. Initially vary Regulated Power Supply (RPS) voltage  $V_s$  in steps of 0.1 V. Once the current starts increasing vary  $V_s$  in steps of 0.02V and note

down the corresponding readings forward voltage of diode ( $V_f$ ) and forward current of diode ( $I_f$ ).

3. Note down different forward currents obtained for different forward voltages in table.
4. Plot the V-I characteristics.
5. Compare the theoretical and practical values.

**(b) Reverse Bias Condition:**

1. Connect the circuit as shown in Fig.2 .
2. Vary  $V_s$  in the Regulated Power Supply (RPS) gradually in steps of 1V from 0V to 12V and note down the corresponding readings of reverse voltage of diode  $V_r$  and reverse current of diode  $I_r$ .
3. Note down different reverse currents obtained for different reverse voltages in table.
4. Plot the V-I characteristics.
5. Compare the theoretical and practical values.

| Forward bias  |            | Reverse bias  |                  |
|---------------|------------|---------------|------------------|
| $V_D$ (Volts) | $I_D$ (mA) | $V_D$ (Volts) | $I_D$ ( $\mu$ A) |
|               |            |               |                  |
|               |            |               |                  |
|               |            |               |                  |
|               |            |               |                  |

**Ideal characteristics graph between  $V_D$  and  $I_D$**

**Forward Characteristic**

**Reverse Characteristic**

**Result:** Volt-Ampere Characteristics of P-N Diode are studied.

### 3.2 LINE TESTER OR PHASE TESTER

Phase or Line Tester is a tool which is used to identify or test the Phase/Live/Hot or Positive wire/Conductor. Phase or Line Tester is also called Neon Screw Driver or Test Pin. (Phase, Line, Hot, Live and Positive are the same terms)

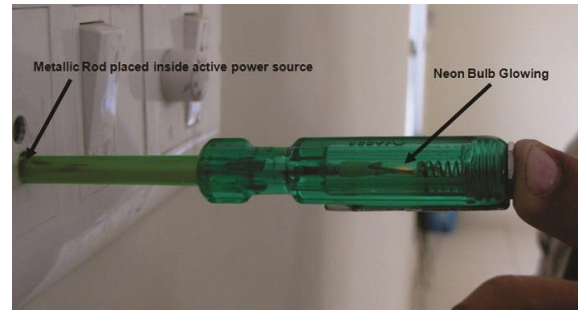


Fig.3.20

Image source: <http://bit.ly/2Oebcqc>

#### 3.2.1 Construction of Phase or Line Tester

Following are the main parts of a typical Phase or Line Tester.

##### 1. Metallic Rod and Mouth

It is a cylindrical metal rod. The flat end (mouth) is used as a screw driver or touch electrical conductors/wires to find phase or live wires and the other end is connected to the resistance, neon bulb, element and metallic cap screw respectively. The flat end of cylindrical metal rod is also covered with transparent insulated plastic for insulation purposes except mouth.

##### 2. Body and Insulation

All these components (Resistance, Neon bulb, Element or metallic spring, and Metallic Cap screw) are covered in a transparent insulated body which made of plastic. The flat end of cylindrical metal rod is also covered with transparent insulated plastic for insulation purposes except mouth.

##### 3. Resistor

Resistor is an element which opposes the flow of current through it. In a Phase or Line Tester, Resistor is connected between cylindrical metal rod and Neon bulb to prevent high current and reduces it to a safe value for Neon bulb. Without a resistor, high current may damage the neon bulb. Moreover it would not be a safe to use this tool without resistor.

##### 4. Neon Bulb

Neon bulb is connected between Resistance and Element (metallic spring). It is used as phase indicator bulb. When a small current flows through it, then it



glows. Due to neon bulb, a Phase or Line tester is also called a Neon Screw driver.

### 5. Element (Metallic Spring)

Element (metallic spring) is used to make connection between neon bulb and metallic cap screw.

### 6. Metallic Cap Screw and Clip

Metallic Cap screw is used for tight all the components inside the Phase tester slot. In addition, Metallic cap screw is connected with spring (element) and spring (element) is connected with neon bulb. Moreover Clip is used for holding the phase tester in pocket.



Fig.3.21

Image source: <http://bit.ly/2Oebcqc>

## 3.3 SCREWDRIVER

A screwdriver is a basic tool used in electrical panel installation. It is manual or powered, for inserting and removing screws. A typical simple screwdriver has a handle and a shaft. The ending tip of the driver is puts into the screw head by the user before turning the handle. The shaft is usually made of tough steel. It is use to resist bending or twisting. The tip may be hardened to resist wear. Handles are made up of wood, metal, or plastic. Handle is usually hexagonal, square, or oval in cross-section to improve grip. This will helpful while twisting the screwdriver and will prevent the tool from rolling on the head of screw. Some manual screwdrivers have interchangeable tips that fit into a socket on the end of the shaft and are held in mechanically or magnetically. These often have a hollow handle that contains various types and sizes of tips.

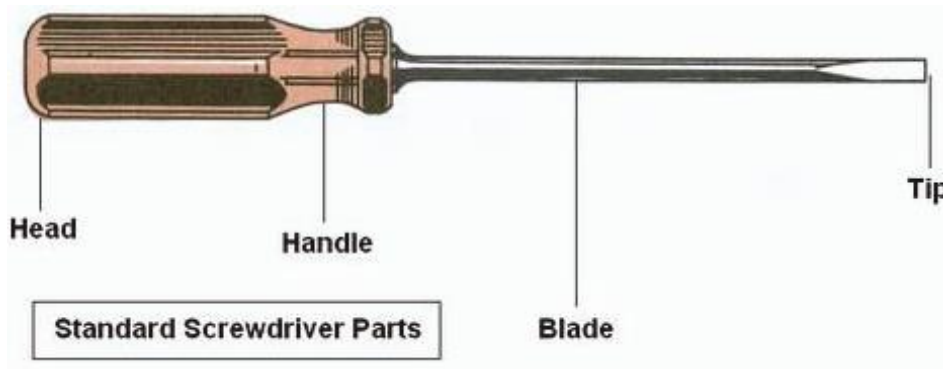


Fig.3.22

Image source: <http://bit.ly/2ALOUKH>

### 3.4 COMBINATION PLIER

Combination pliers as the name suggest perform various operation. It enables the user to perform the combine operation i.e. cutting and gripping. Some combination pliers have other additions, especially if they are designed for use in particular industries or for specific tasks.

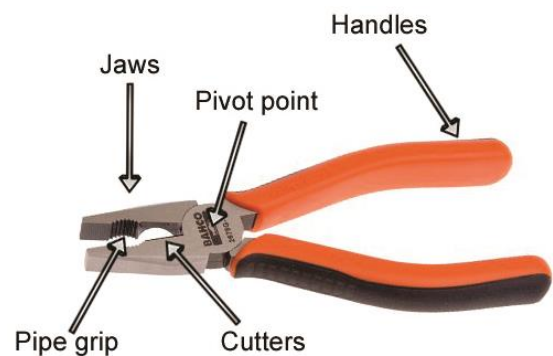


Fig.3.23

Image source: <http://bit.ly/2voFWOb>

- **Handles**

The handles of combination pliers will usually have a plastic coating, for added comfort and grip. The size and length of the handles will depend on the size of the pliers. Pliers designed for use by electricians and linemen have insulated handles.

- **Jaws**

The jaws of combination pliers open and close along with the handles. They have flat edges for general gripping, which are often serrated for extra grip, although sometimes they are smooth. They usually have squared tips.

- **Cutter**

The cutters built into the jaws of combination pliers are usually designed to cut cables and wire.

- **Pipe grip**

The pipe grip is a rounded, cut-out in the jaws. It is primarily used for gripping rounded stock, like pipes and cables.

- **Pivot point**

The pivot point is a kind of hinge that allows the handles and tips to open and close so the jaws can grip or cut, and then be opened again.

### 3.5 DRILL BITS

Drill bits are cutting tools used to remove material to create holes. Drill bits are used in of circular motion. Drill bits come in many sizes and shapes. Different size of holes can be made by using different size of bits. In order to create holes drill bits are usually attached to a drill machine, which powers them to cut through the work piece, typically by rotation.

- Insert the chuck key. If your drill came with a chuck key, you will need to use this in order to loosen the chuck. To insert the chuck key, line up the teeth so that they match the teeth on the chuck and insert the tip into one of the holes on the side of the chuck.



Fig.3.24

Image source: <http://bit.ly/2KBznwG>

- Turn the chuck key counterclockwise. As you turn the key, the jaws on the chuck will begin to open. Continue turning until the chuck opens enough to easily slide the drill bit out. The jaws are the three or four pieces in the mouth of the chuck that extend to hold the bit in place.



Fig.3.25

Image source: <http://bit.ly/2KBznwG>

- Remove the bit. Pull the bit out using your thumb and index finger once the chuck is loosened. If the chuck is opened wide and you turn the drill face down, it may just fall out.
- Inspect the bit. Check for damage. If the bit is dull, replace it. If it is bent or shows signs of cracking, throw it out.

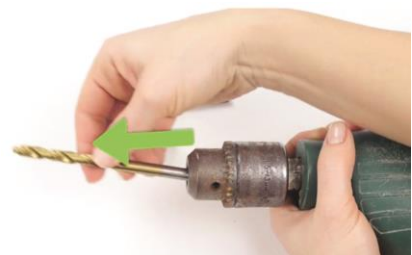


Fig.3.26

Image source: <http://bit.ly/2KBznwG>

- Insert a bit. While the jaw on the chuck is open wide, insert new bit. Hold the bit with your thumb and index finger so that the smooth part of the bit (the shank) is facing the jaws of the chuck and insert it.
- Keep your fingers on the bit and the chuck since the bit is not secured and could fall out.



Fig.3.27

Image source: <http://bit.ly/2KBznwG>

### 3.6 WIRE LUGS

Wire lugs are a connecting terminal use to connect the conductor wire to the external world. Wire lugs are a class of electrical connector which is used to transfer electrical current from a power or grounding source to a user. Terminals "terminate" by using crimping or soldering technique. In which conductor of wire is connected to the metallic connector which called as a lug.



Fig.3.28

Image source: <http://bit.ly/2nk7OPq>

### 3.7 WIRE STRIPPER

A wire stripper is a portable handheld tool used by workers, especially electricians, for removing the protective coating of an electric wire in order to replace or repair the wire. It is also capable of stripping the end portions of an electric wire in order to connect them to other wires or to terminals. A wire stripper is often considered an important tool for professional electricians and other related personnel.



Fig.3.29

Image source: <http://bit.ly/2M3ivBa>

Wire strippers can be categorized into two types: manual wire strippers and automatic wire strippers. A manual wire stripper is considered the most versatile; to use it, the user needs to manually rotate it while applying pressure around the insulation in order to cut or adjust the wires. In the case of an automatic wire stripper, one side is held tight and, simultaneously, the other side is cut and removed. An automatic wire stripper can help even a novice cut and strip most wires quickly. However, it only works for certain size ranges of wires. It could break small wires, and large wires may not fit into its jaws.

Wire strippers are available in various shapes and sizes and are usually made of steel. They usually have serrated teeth, which comes handy while stripping wires. The handles can be either straight or curved and, in most cases, are covered with rubber coating to provide a secure grip. Wire strippers often have a wire cutter as well.

### 3.8 WRENCH

The pipe wrench is an adjustable wrench/spanner used for turning soft iron pipes and fittings with a rounded surface. The design of the adjustable jaw allows it to lock in the frame, such that any forward pressure on the handle tends to pull the jaws tighter together. Teeth angled in the direction of turn dig into the soft pipe. They are not intended for use on hardened steel hex nuts or other fittings because they would ruin the head; however, if a hex nut is soft enough that it becomes rounded beyond use with standard wrenches, a pipe wrench is sometimes used to break the bolt or nut free. Pipe wrenches are classified by the length of the handle; they can be available in any size from as small as 3 inches up to 48 inches or larger. They are usually made of cast steel. Today, aluminium is also used to construct the body of the wrench, while the teeth and jaw remain steel. Teeth, and jaw kits (which also contain adjustment rings and springs) can be bought to repair broken wrenches, as this is cheaper than buying a new wrench.

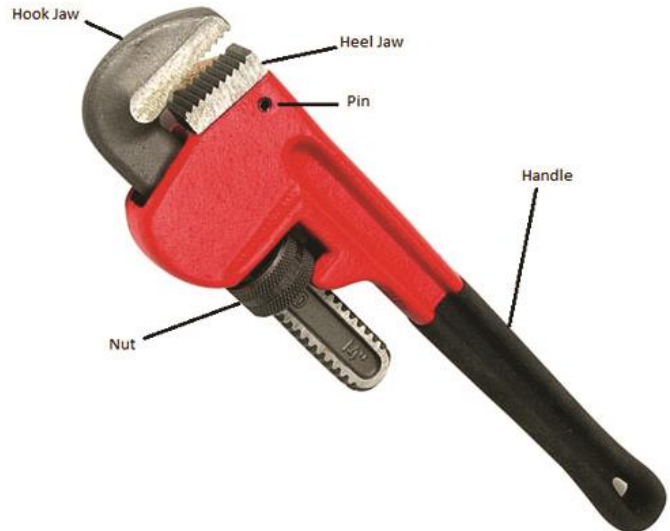


Fig.3.30

Image source: <http://bit.ly/2MpLuic>



### 3.9 HAMMER

A tool consisting of a piece of metal with a flat end that is fixed onto the end of a long, thin, usually wooden handle, used for hitting things, shaping of metal sheets etc.



Fig.3.31

Image source: <http://bit.ly/2ARuoIH>

### 3.10 LADDER

A ladder is a vertical or inclined set of steps. There are two types: rigid ladders that are self-supporting or that may be leaned against a vertical surface such as a wall, and rollable ladders, such as those made of rope or aluminum that may be hung from the top. The vertical

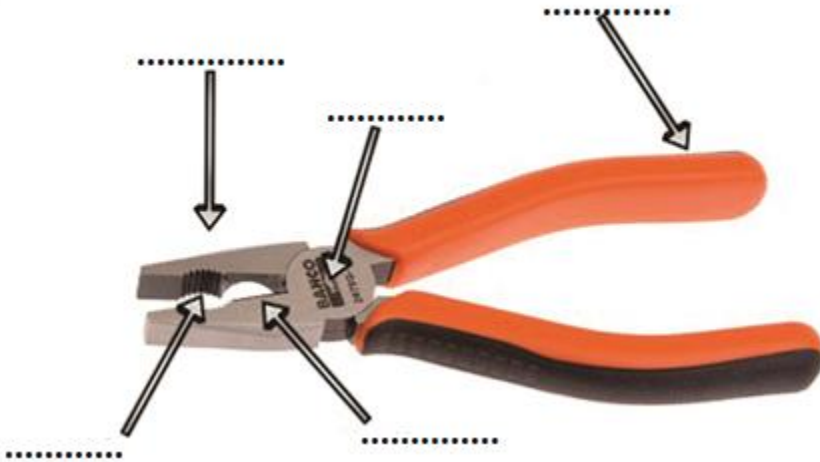
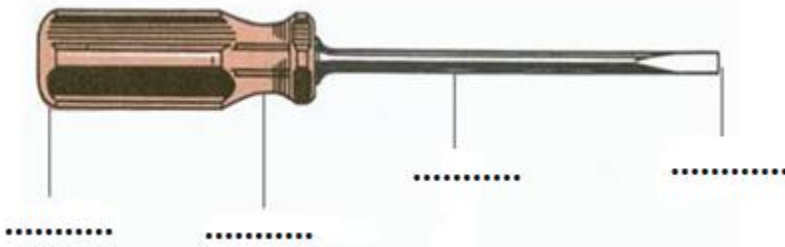


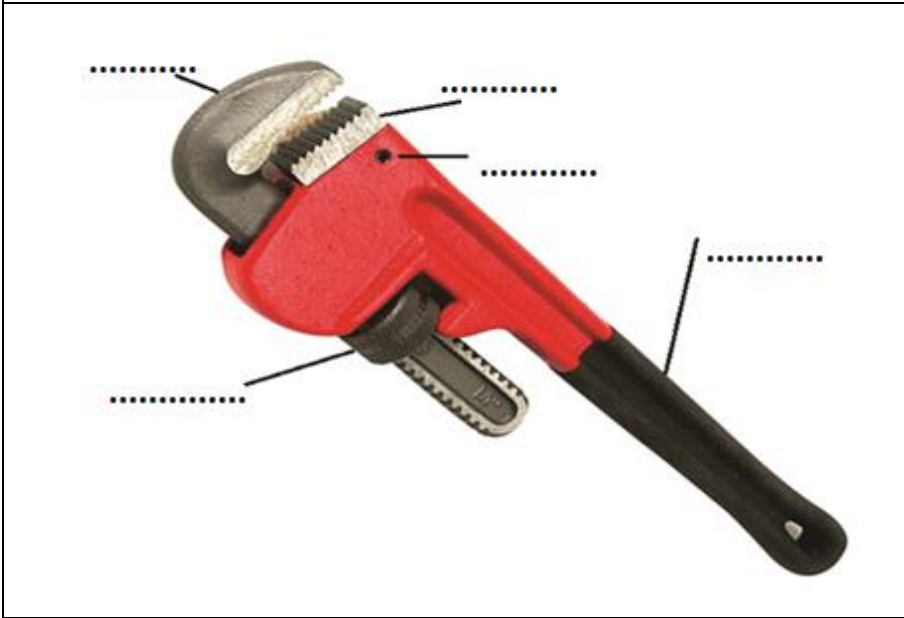
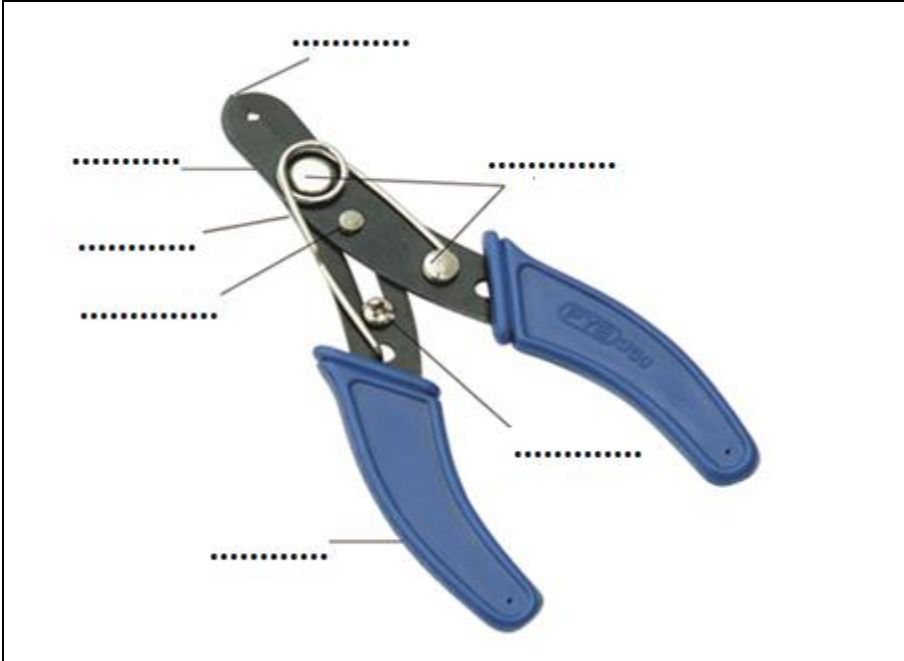
Fig.3.32

Image source: <http://bit.ly/2KB6rEZ>

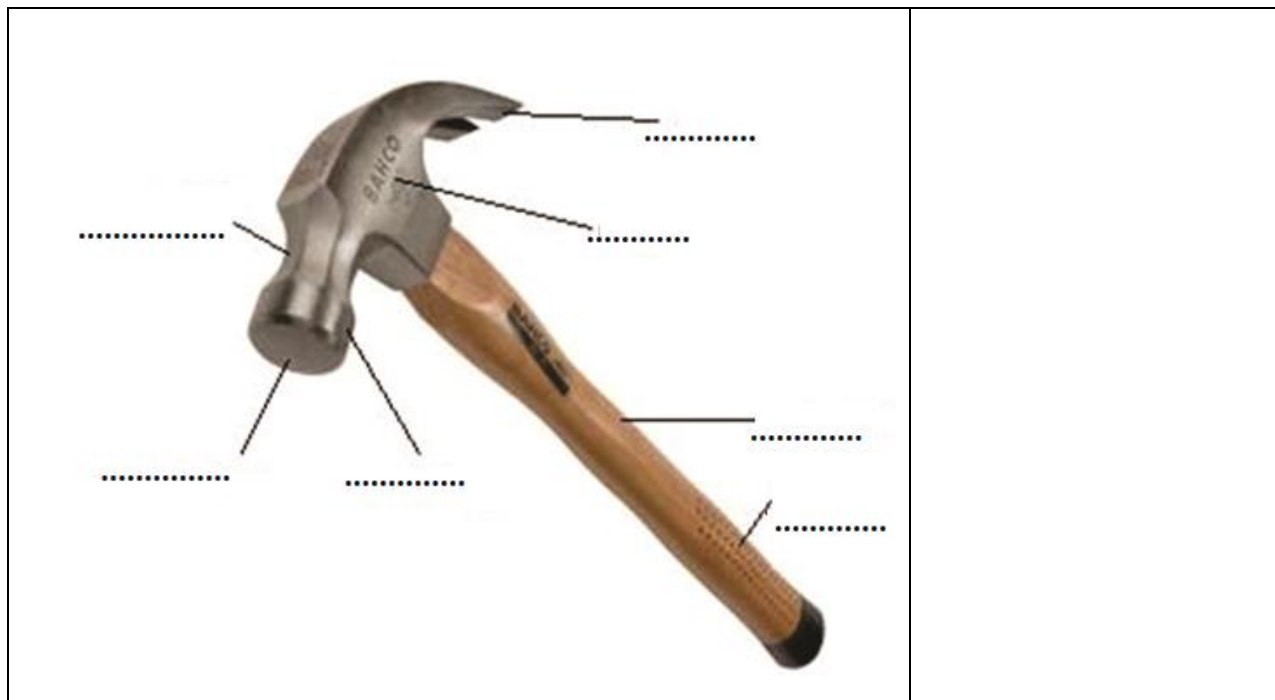
members of a rigid ladder are called stringers or rails. Rigid ladders are usually portable, but some types are permanently fixed to a structure, building, or equipment. They are commonly made of metal, wood, or fiberglass, but they have been known to be made of tough plastic.

**Practical activity:** Identify and name the various tools and its parts.









**Practical activity:** Use the general tools for given task.

List the name of general hand tools and write down the use of listed tools.

### 3.11 TONG TESTER

A clamp meter is a tool for measuring current on a wire. In comparing with multi-meter, the clamp meter does not need to be connected to the circuit in order to read current. Clamp meter does not require unnecessary procedure of breaking the circuit to measure current. The clamp on the device is simply placed around a live wire. This allows one to measure the current on a wire without interrupting the operation of the electrical appliance. A clamp meter uses digital technology to bring instantaneous readings.



Fig.3.33

Image source: <https://amzn.to/2ANBUUJ>

**Practical activity:** Measure the current using clamp meter.

Steps for measuring AC or DC current use a clamp meter's jaws are as follows:

- **Choose an electrical conductor to test**

The clamp can easily measure the current on a load without the need to disconnect the electrical conductor from the circuit. To get a reading, the electrical wire should be connected to an electrical appliance that is running or operating.

- **Choose the appropriate function and range**

Set the rotary selector on the clamp meter to the correct function and range. Measuring current that is higher than that specified in the range can damage the device. If you are not sure about the range of current which is to be measure, choose a high range and decrease it as needed.

- **Clamp the conductor**

Push the trigger on the device to open the jaw. Clamp the device around the conductor and close it. If the electrical conductor is not yet connected to a power source, connect it. Note the reading on the display of clamp meter.

- **Use an AC line separator**

When measuring AC current, the device may give a false reading. Hot and neutral current cancel each other out, which causes the device to display nothing on the LCD screen. To correct the problem, connect the AC line separator between the electrical conductors i.e. phase and neutral.

- **Measure Voltage**

Set the clamp meter to the voltage symbol “V” to read the voltage on the conductor. Plug the probes to the meter as well. Connect the black probe to the COM jack and the red probe to the V/O jack. Select the correct range and make sure not to measure voltages above than the maximum range of the clamp meter. Touch the tips of the probes to the electric conductor to get a voltage reading. Read the voltage on the LCD screen.

A clamp meter will save you time during an electrical repair work, will help you get more efficient with your wiring projects, and will protect you from electrical-related accidents.

### **3.12 TOTAL DISSOLVED SOLIDS (TDS) METER**

Total Dissolved Solids (TDS) is about the purity of water. It defines total amount of mobile charged ions, including minerals, salts or metals dissolved in a given volume of water. It is expressed in units of mg per unit volume of water

(mg/L). Also, referred to as parts per million (ppm). TDS is directly related to the purity of water and the quality of water purification systems.



Fig.3.34

### 3.13 MEGGER

Insulation resistance IR quality of an electrical system degrades with time, environment condition, i.e., temperature, humidity, moisture and dust particles. It also gets impacted negatively due to the presence of electrical and mechanical stress, so it's become very necessary to check the IR (Insulation resistance) of equipment at a constant regular interval to avoid any measure fatal or electrical shock. Megger meter is used as a measuring instrument for insulation resistance tester.

#### 3.13.1 Uses of Megger

The device enable us to measure electrical leakage in wire, results are very reliable as we shall be passing electric current through device while we are testing. The equipment basically uses for verifying the electrical insulation level of any device such as motors, cables, generators, windings, etc. This is a very popular test being carried out since very long back. Not necessary it shows us exact area of electrical puncture but shows the amount of leakage current and level of moisture within electrical equipment/winding/system.

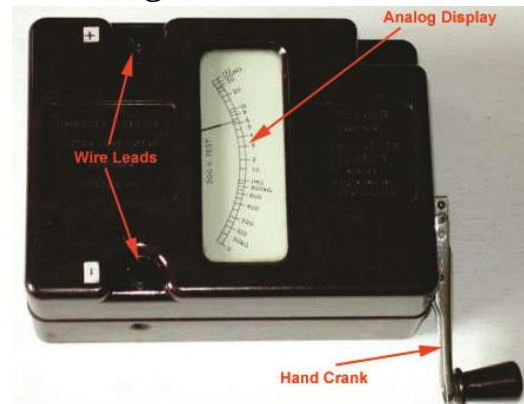


Fig.3.35, Courtesy: <http://bit.ly/2nfKodU>

#### 3.13.2 Types of Megger

This can be separated into mainly two categories:-

- Electronic megger (Battery Operated)
- Manual megger (Hand Operated)

But there is another types of megger which is motor operated type which does not use battery to produce voltage it requires external source to rotate a electrical motor which in turn rotates the generator of the megger.

## Electronic Megger

Important parts:

- **Digital Display:** A digital display to show IR value in digital form.
- **Wire Leads:** Two wire leads for connecting megger with electrical external system to be tested.
- **Selection Switches:** Switches use to select electrical parameters ranges.
- **Indicators:** To indicate various parameters status i.e. On-Off. For Example Power, hold, Warning, etc.

## Manual Megger

**Analog display:** Analog display provided on front face of tester for IR value recording.

**Hand Crank:** Hand crank used to rotate helps to achieve desired RPM (rotation per minute) required generate voltage which runs through electrical system.

**Wire Leads:** Used same as in electronic tester i.e. for connecting tester with electrical system.

### 3.14 SOLDERING

Soldering is the process of melting a metal onto other metal components in order to bind them. Soldering differs from welding. In welding, the component pieces are melted together; in soldering, a softer metal with a lower melting point is used to connect them. Because soldering doesn't melt components, it is useful for more delicate applications, such as electronics work, or plumbing. The purpose of soldering is to bind two other components. Solder can be thought of as a sort of “metal glue.” It can be used to fill in gaps or hold pieces in place, but doesn't serve any more complicated purpose. Since solder is metallic, it conducts electricity, which is another reason it's so popular for connecting electronic components.



Fig.3.36

Image source: <http://bit.ly/2APAU2E>

**Practical activity:** Demonstrate the soldering and de-soldering techniques.

To practice soldering and de-soldering for the given electronic circuit in a general purpose printed circuit board (PCB).

**Apparatus required:**

PCB board for given circuit, soldering iron, solder, copper plate, flux, connecting wires, lead, and nose plier.

**Procedure:**

**Soldering:**

1. Clean the given PCB board.

*Fig.3.36*

2. Clean the tip of the soldering iron before heating and also clean the components which are to be soldered.

3. Heat the soldering iron and apply solder to the tip as soon as it is hot to melt on it.

*Fig.3.37*

4. Considering given circuit and the components are to be soldered in their respective place by applying hot tip to the joints.

5. Trim excess component lead with side cutter.

*Fig.3.38*

**De-soldering:**

1. Hold the component to be unsoldered by a nose plier.

*Fig.3.39*

2. Place the tip of the soldering iron on the joint until the solder is melt.

*Fig.3.40*

3. When the solder is melted, remove the component with a tweezer and brush away the molten solder.

*Fig.3.41*

4. Clean the components so that they can be used to make other circuits.

*Fig.3.42*

**Result:** Thus the soldering and de-soldering practice is done for the given electronic circuit successfully.

## **CHECK YOUR PROGRESS**

### **A. Choose the correct option from those given below**

1. A screw is made up of \_\_\_\_ wrapped around a post or rod.
  - a) treads
  - b) springs
  - c) threads
  - d) strings
2. Which of the following tool is used for shaping the metal into a sheet.
  - a) Hammer
  - b) Screwdriver
  - c) Stripper
  - d) Wrench
3. Pipe wrenches are available in size from ..... inches up to ..... Inches.
  - a) 1, 50
  - b) 3, 48
  - c) 4, 58
  - d) 1, 45
4. Wire stripper is categorized as ..... and .....
  - a) Vertical and horizontal
  - b) Straight and aligned
  - c) Manual and automatic
  - d) Fix and movable
5. Which of the following is used as a wire connector.
  - a) Lugs
  - b) Screwdriver
  - c) Stripper
  - d) Hammer
6. Which of the following meter is used for insulation resistance testing.
  - a) Ammeter
  - b) Voltmeter
  - c) Wattmeter
  - d) Megger meter

7. Which of the following equipment is used to measure the AC voltage.
  - a) Tachometer
  - b) Multimeter
  - c) Ammeter
  - d) Megger meter
8. Which of the following meter is used to measure insulation resistance.
  - a) Tachometer
  - b) Multimeter
  - c) Ammeter
  - d) Megger meter
9. Which of the following tool is used for turning soft iron pipes and fittings with a rounded surface.
  - a) Wrench
  - b) Plier
  - c) Wire stripper
  - d) screwdriver
10. Which of the following tool is used for the removal of the insulation of wire.
  - a) Plier
  - b) Wrench
  - c) Wire stripper
  - d) Hammer

**B. Fill in the blanks with correct word**

1. Combination plier is used for ..... and .....
2. Pipe wrench is classified by the length of the handle; they can be available in size from ..... inches up to ..... inches.
3. The process of melting a metal onto other metal components in order to bind them is called as .....
4. Tong meter is also known as ..... meter.
5. Megger meter is classified as ..... and .....
6. Soldering is also known as .....
7. Ladder is classified as ..... and .....
8. In line tester ..... Bulb is used for the indication of live wire.
9. In drilling practise ..... is used for making hole on the wall or wood.

10. Multimeter is used for the measurement of resistance, voltage, and .....

**C. State whether the statement given below are true or false**

1. Soldering is known as glue.
2. Clampmeter is used to measure the current flowing inside the wire.
3. Multimeter is used for the testing of diode.
4. Combination plier is used for the stripping of the insulation in the wire.
5. Line tester is used for testing diode.
6. Multimeter can measure AC and DC voltage.
7. Lugs are used as a wire connector.

**D. Match the column**

|                 |  |
|-----------------|--|
| 1. Hammer       | a) To check the line or Live wire                      |
| 2. Screwdriver  | b) grip and twist the pipe                             |
| 3. Phase tester | c) Tighten the screw                                   |
| 4. Plier        | d) Shaping of metal sheet                              |
| 5. Wrench       | e) Used for cutting, stripping of wires, holding wire. |

**E. Short answer type question**

Write short note on:

1. Screwdriver
2. Megger meter
3. Multi meter
4. Combination plier
5. Line tester



# INSTALLING AN RO WATER PURIFIER

## INTRODUCTION

We mostly associate diseases with a change in weather or having food in unhygienic locations. But we tend to overlook the fact that even water can cause these diseases. Through tap water you might be unknowingly consuming substances like chlorine, Trihalomethanes (THMs), pesticides and much more. All it takes is one simple step to avoid this problem, *installing a water purifier*. Make sure to choose water purifiers with an extensive filtering process so that something as simple as drinking water can be consumed without a worry.

RO water purifiers feature advanced purification process and even provide you with a digital advance alert system that reminds you before the Germ Kill Kit expires. These purifiers use RO and UV technology to make water potable for you. A complete package for absolute health assurance.

## PRE-INSTALLATION REQUIREMENT

### 4.1 BASICS OF WATER- BASED APPLIANCES

Water is a chemical substance that is essential to all known forms of life. Water is the most abundant compound found on Earth. It is the basics requirement of living being. Water is essential for the survival. More than 70% of Earth's surface is covered with water in the form of snow, glaciers, oceans, rivers and lakes. However, very little of this water is drinkable. This is because 96% of the earth's water is salt water. Approximately, 98% of the remaining fresh water is in the form of glaciers and polar ice caps. This leaves just about 1% of the freshwater on the surface in the form of rivers and lakes. Not all of this fresh water is safe for human consumption as it is contaminated with bacteria. To make fresh water safe for drinking, it needs to be cleaned so that its intake does not cause any harm. The various properties of water make it a necessity or supporting life.



## Distribution of water on Earth

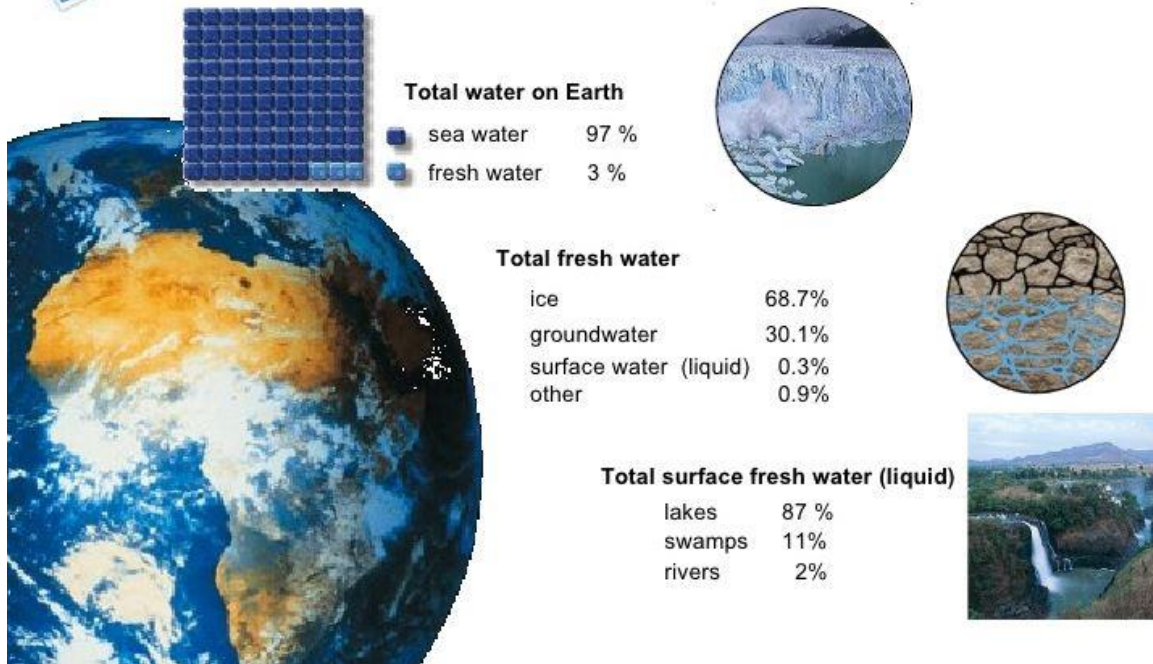


Fig. 4.1: Percentage of water on earth

### 4.1.1 Properties of Water

Water is a transparent, odorless, tasteless and colorless liquid. Its chemical name is  $H_2O$  and it is made up of two hydrogen atoms and one oxygen atom joined together by covalent bonds.

## Characteristics of the water

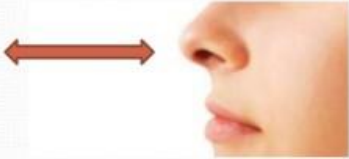

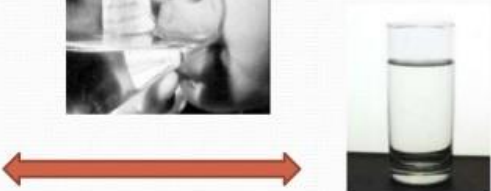
- Water has no smell 
- Water has no taste 
- Water has no colour 

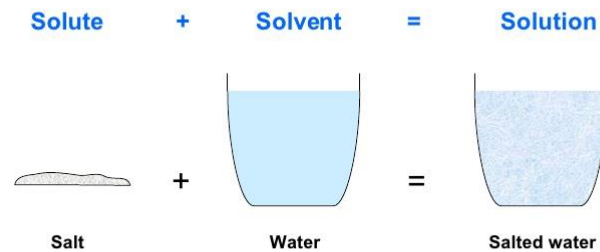
Fig.4.2: Properties of water

The following figure lists the various properties of water:

- **Universal Solvent**

Water forms hydrogen bonds. These bonds make it a powerful solvent. Water can dissolve different chemicals. Water contains various minerals, nutrients and chemical. This property of water helps to support the life on Earth.

#### 4. THE UNIVERSAL SOLVENT



A solution is a homogeneous mixture. The most abundant part is called the solvent, and the less abundant part is called the solute.

*Fig.4.3: Water as a universal solvent*

- **High Specific Heat**

Water is helpful in maintaining the moderate temperature of earth. As water has capacity to absorb the heat. Water has high specific heat. Specific heat is the property of substance which represents the amount of heat required to raise the temperature of each molecule by one degree. Each molecule of water has specific heat with them this will help to maintain the temperature of earth.

**Specific Heat Capacity**

- The heat needed to raise the temperature of 1kg of water by 1°C is termed the **Specific Heat Capacity**.
- Water has a large specific heat capacity, and therefore can absorb large amounts of heat energy before its temperature raises a significant amount.

thermometer

1kg of water

WJEC GCE BIOLOGY Properties of Water

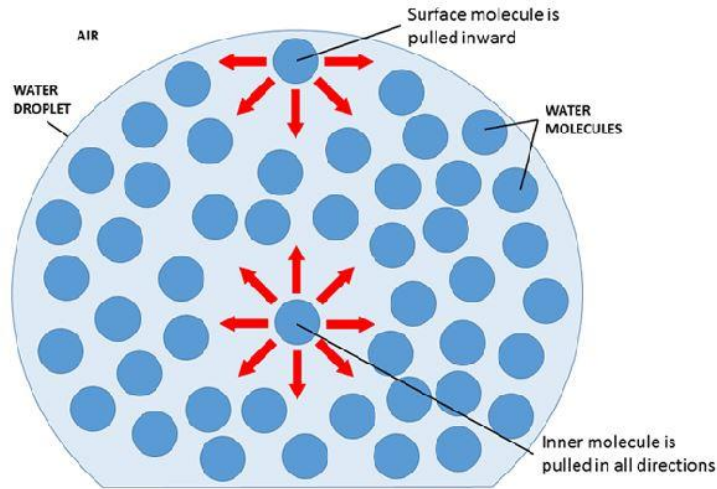
WJEC CBAC

← Back

*Fig. 4.4: Specific heat of water*

- **Strong Surface Tension**

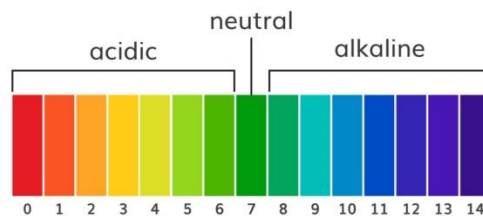
Water has a high surface tension. Molecules of water have high adhesive property. High surface tension is responsible for the capillary action of water. This capillary action helps to move water through the plant roots and stems and even blood vessels in animal.



*Fig. 4.5: Surface tension of water*

- **Neutral pH**

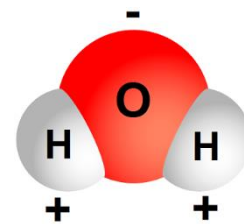
Water is neither acidic nor basic; it has a neutral pH value 7.



*Fig. 4.6: pH of water*

- **High Polarity**

A water molecule consists of one oxygen atom and two hydrogen atoms. Oxygen has a very high electronegativity, meaning it has a very high affinity for electrons. The oxygen in water molecules pulls the electrons from the hydrogen atoms closer to it, creating two poles in the molecule, where the hydrogen end is partially positive and the oxygen end is



*Fig.4.7: Polar nature of water*

partially negative. Water has a high polarity. The difference in the electro negativity of oxygen and hydrogen atoms makes a strong polar compound.

- **Lower Density of Ice**

The density of ice is lower than the density of water. Water expands when it freezes. Its molecules form a crystalline structure. The density of ice is lower than the density of water. Water expands when it freezes. Its molecules form a crystalline structure. As density of ice is less than water. Ice starts float on the surface of water. Prevent oceans, lakes and rivers from freezing, thereby allowing life to exist on Earth.

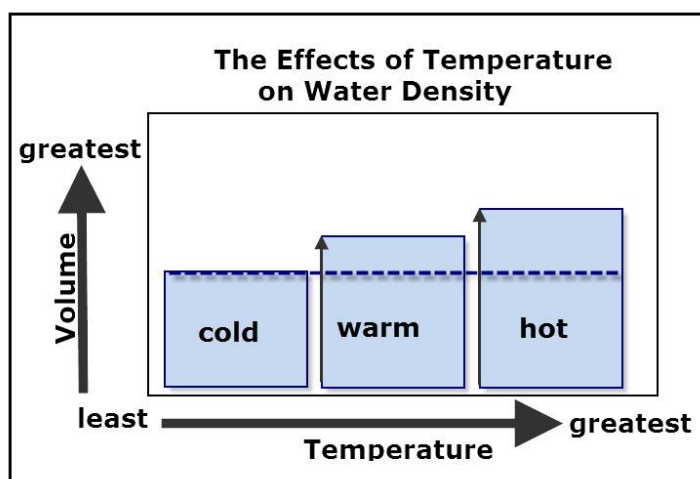


Fig. 4.8: Density of water

**Activity: Group discussion**

More than 70% of Earth's surface is covered with water in the form of snow, glaciers, oceans, rivers and lakes. Still there is lack of water. Discuss.

## 4.2 WATER TREATMENT METHOD

### 4.2.1 Water Treatment

In everyday life clean and safe is essential. But, contaminants like germs, virus, bacteria, and parasite etc. are present in the water. Therefore for making the water drinkable treatment of water is necessary. Water treatment is the process of removing the microorganism from water. The following figure lists the purpose of water treatment:



Fig. 4.9: Purpose of water treatment

### 4.2.2 Water Treatment Methods

There are four common types of contaminants that are generally found in water. These are shown in the following figure:

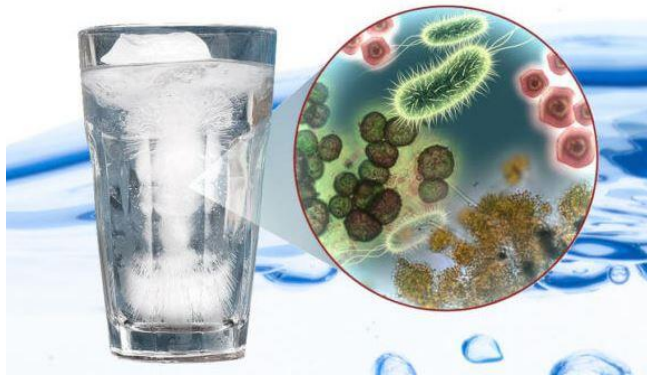


Fig.4.10 (a): Contaminants in water

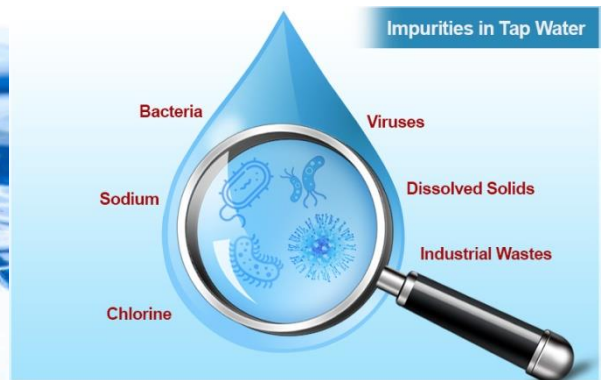


Fig.4.10 (b)

Courtesy: <http://bit.ly/2yHzKSz>

#### a) Bacteria

Bacteria are a group of very small organism. Generally, bacteria are harmless but some of them harm humans. Bacteria cause sickness and disease in human. Diseases which are caused by the bacteria are vomiting, diarrhea, intestinal infection.

#### b) Minerals

Minerals are substances that are formed naturally in the Earth. Minerals are usually form by geological processes. Minerals like calcium, potassium, and magnesium are considered good for the human. While some such as lead arsenic and aluminum are considered harmful for the human. Water has both type of mineral dissolve in it. Level of mineral dissolve in water determines the content of hardness.

#### c) Particulates

Particulates are the small particles. They are present in the environment due to air pollution. They are dust sand sediment rust found in the water. Particulates carry harmful diseases with them that will harm the human. They are measured in microns where one micron is one millionth of a meter.

#### d) Chemicals

Chemical contain in the water can be natural or man-made. Mainly chemicals added into water through pollution industrial discharge, urban activities, agriculture, and disposal of waste. Water treatment methods remove contaminants from the water to make it safe for human consumption. Water treatment is done at two levels:

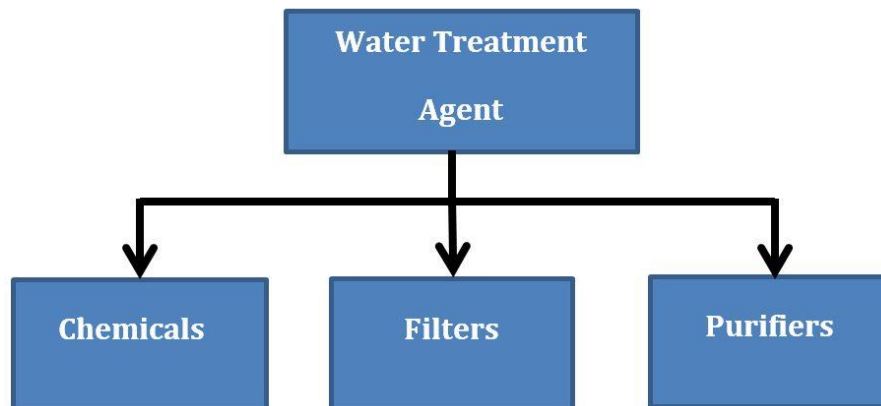
|                                  |   |
|----------------------------------|---|
| <i>Community water treatment</i> | Surface water treatment plant is use for the removal of contaminants from |
|----------------------------------|---|



|                                 |   |
|---------------------------------|---|
|                                 | the public drinking water.  |
| <i>Domestic water treatment</i> | Individual water treatment at home is done such as filter, contaminants removal is done to improve the taste of taste of water. |

### 4.2.3 Different types of agents

Different types of agents are used for the water treatment. This will make water safe for drinking. These water treatment agents are classified as into three categories which are as follows:



*Fig.4.11: Water treating agent*

#### a) Chemicals

Chemicals are used for the treatment of water. Commonly use chemical for water treatment are chlorine, chlorine dioxide and ozone. These chemicals kill unwanted small organism or micro-organism present in the water. This will improve the taste, odor, clarity of the water. Excessive use of chemical for the water treatment may damage the human body.

#### b) Filters

Filters reduce contamination of water by removing the impurities. Filter acts as a physical barrier or a biological process for the impurities. There are four main types of filters as shown in the following:

1. Sediment filter
2. Carbon block filter
3. TFC/TFM Membrane filter
4. Inline carbon filter

## 1. Sediment filter

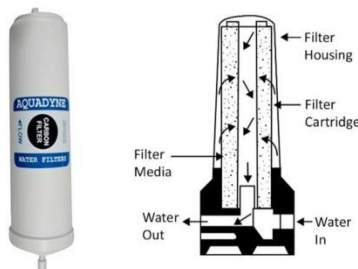
Sediment filters are used to reduce solid particulate. Sediment filters remove suspended matter such as sand, silt, loose scale, clay, or organic material from the water. Untreated water passes through sediment filter, these filters can remove insoluble or suspended particles. In drinking water treatment sediment filtration can be an option for treatment of water problems. Sediment filters do not remove dissolved material that may be harmful. They do not remove contaminants such as chlorine, lead, mercury etc.



*Fig.4.12: Sediment filter*

## 2. Carbon filter

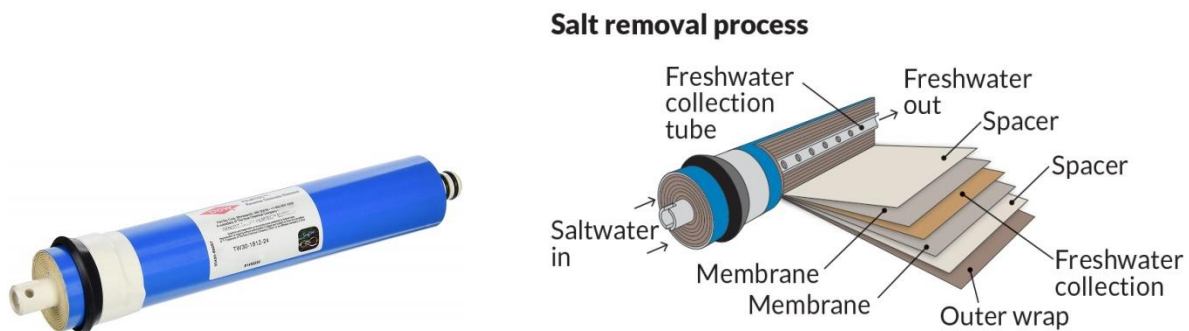
Carbon uses chemical absorption for filtration of water. Carbon is activated by adding positive charge which enhances the surface area as well as the ability of the filter. Carbon filter removes chlorine, arsenic, lead, asbestos, salts or metals.



*Fig.4.13: Carbon filter*

## 3. TFC/TFM Membrane filter

TFC/TFM is semi-permeable membrane used in the reverse osmosis (RO) water purification system. Untreated water is forced through the membranes which acts like a strainer and allow pure water to pass through leaving the dissolved contaminants behind.



*Fig. 4.14: TFC/TFM membrane filter*



Courtesy: <http://bit.ly/2Ouax8L>

#### 4. Inline carbon filter

Carbon filters can also be installed inline as part of the reverse osmosis water purification system. They are used as pre-treatment to safeguard other water treatment unit such as TFC/TFM membranes, from any damage due to organic pollutant or oxidation.



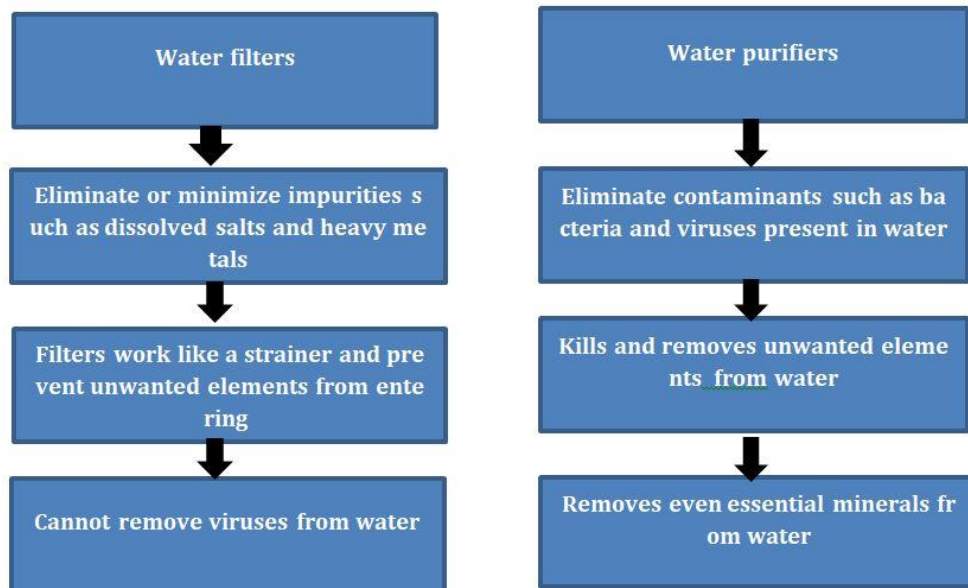
*Fig.4.15: Inline carbon filter*

Courtesy: <http://bit.ly/2J0QIQz>

#### c) Purifiers

Water purifiers remove contaminants such as excess salts, suspended particles and microbes dissolved in water and preserve its necessary vitamins and minerals. Purifier deactivating deadly bacteria and viruses making the water safe for consumption. These unique water purifiers also come with a storage tank. They are ideal for purifying tap and municipal water. Water purifiers are based on patented Mineral RO technology. Purifier uses double purification to combine Reverse Osmosis (RO) and Ultraviolet (UV) / Ultra Filtration (UF) in a multistage filtration process. It removes even dissolved impurities and retains essential minerals giving pure and safe drinking water. The difference between water filters and purifiers is the type of impurities removed by each one of them.

The following figure lists the main differences between the two:

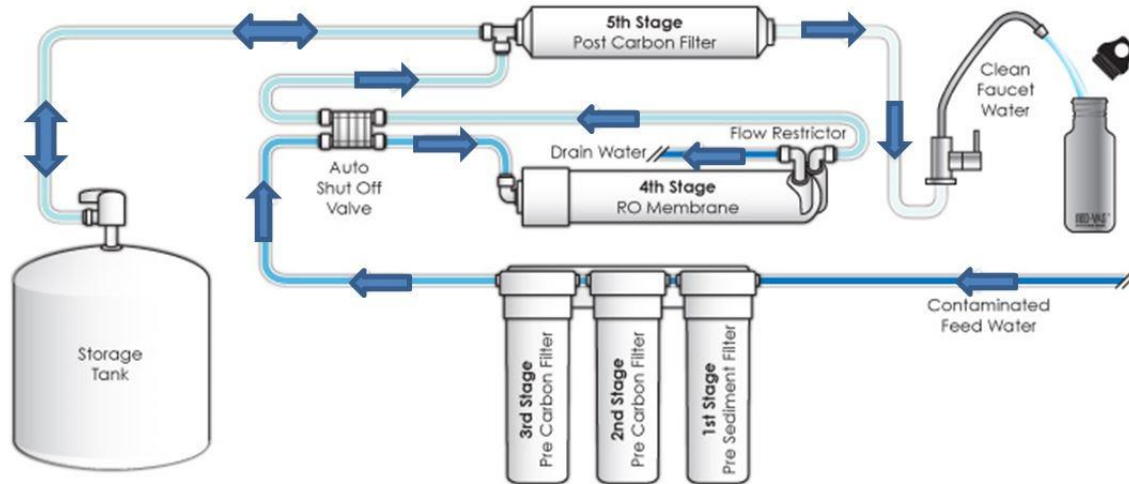


*Fig. 4.16: Water Filters vs. Water Purifiers*

**Practical activity:** Identify the structural requirements.  
 Discuss the terms considered for structural requirement of the water purifier.

### 4.3 WATER FLOW DIAGRAM AND ELECTRIC CURRENT FLOW DIAGRAM OF RO WATER PURIFIER

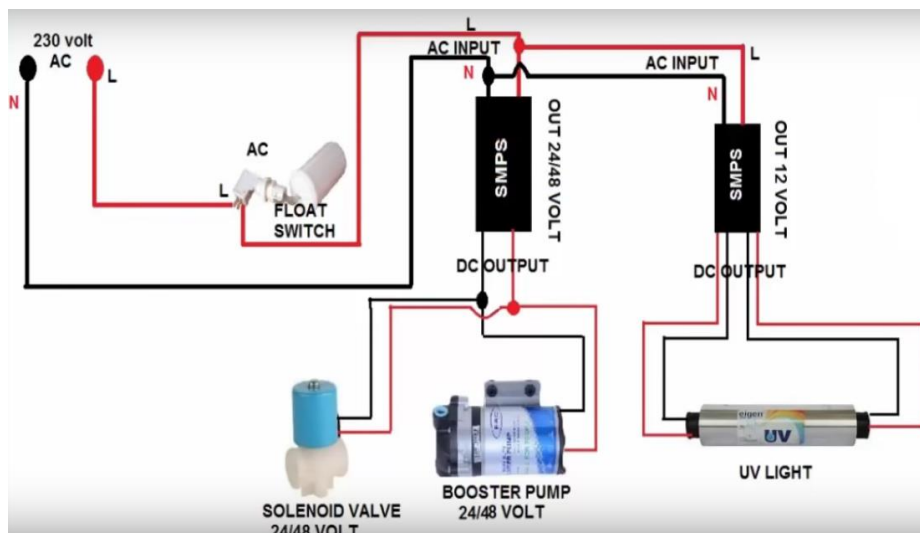
The following figure shows the flow of water in an RO purifier:



**Fig.4.17: Water flow in an RO water purifier**

Courtesy: <http://bit.ly/2EoyBFh>

The following figure shows the flow of electric current in an RO purifier:



**Fig.4.18: Electrical circuit diagram of an RO Water Purifier**

Courtesy: <http://bit.ly/2CPen6e>

## 4.4 WATER PURIFICATION PROCESS AND DIFFERENT LAYERS OF FILTER

### 4.4.1 Water Purification Process

Water purification is the process of removing contaminants from untreated or raw water to get pure water that is safe for consumption. It consists of three different processes as shown in the following figure:

|                    |   |
|--------------------|---|
| Physical process   | Filtration sedimentation and distillation                   |
| Biological process | Slow sand filters or biologically active carbon             |
| Chemical process   | Flocculation, chlorination and the use of ultraviolet light |

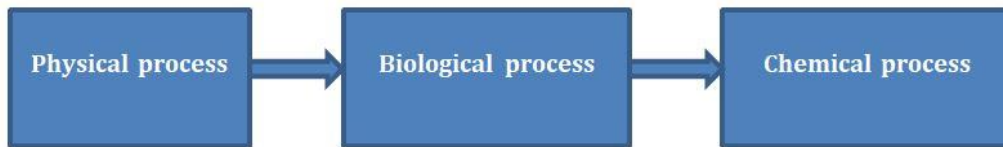


Fig.4.19: Water purification processes

### 4.4.2 Steps of the Purification Process

The water purification process consists of four major steps as shown in the following figure:

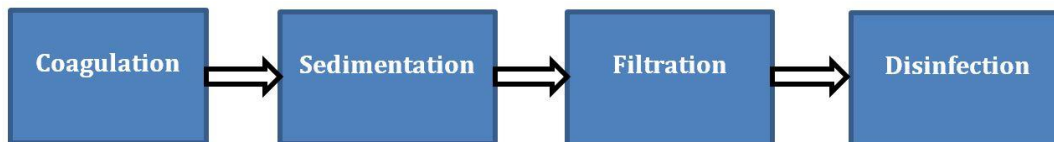
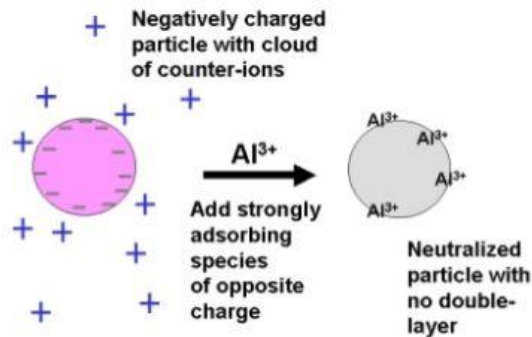
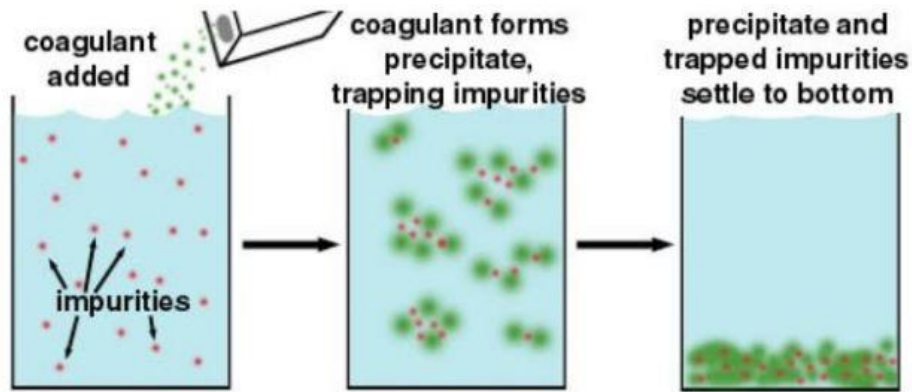


Fig.4.20: Water purification processes

#### a) Coagulation

Coagulation in water purification is a process of transforming small particles to bigger particles. In impure water very small particles are present, these particles are not able to filter using a strainer. To filter out these small particles, chemicals are added. The most common form of chemical is alum. Alum is positively charged, which neutralizes the negative charge of small particles. Then the particles can stick together, forming larger particles which are more easily removed. When the water from ground, lakes, or river enters a water treatment plant, it is coagulated by the addition of alum and other chemicals. These heavy particles will sink to the bottom.

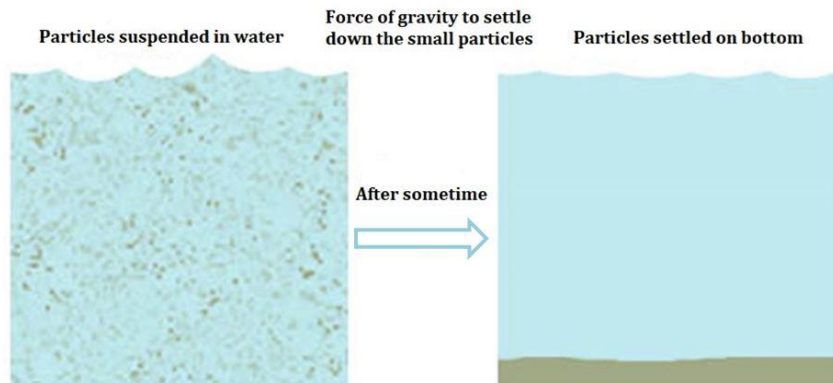


*Fig.4.21: Coagulation*

Courtesy: <http://bit.ly/2yHbSy>

**b) Sedimentation**

Sedimentation is a physical process of water treatment. Sedimentation uses force of gravity to settle down the small particles. All the suspended particles are settle down at the bottom under the effect of gravity.

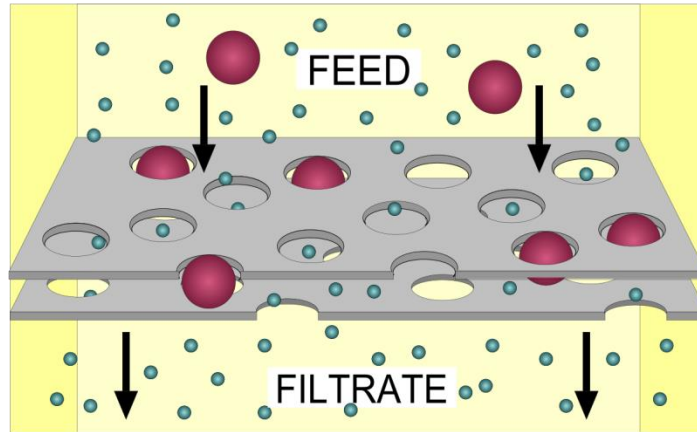


*Fig.4.22: Sedimentation*

**c) Filtration**

Filtration is the process of separating suspended solid matter from a liquid. This is performed by passing the water through pores of some substance,

called a filter. The filtration tanks consist of layers of gravel and sand which filter out the remaining contaminants.



*Fig.4.23: Filtration*

**a) Disinfection**

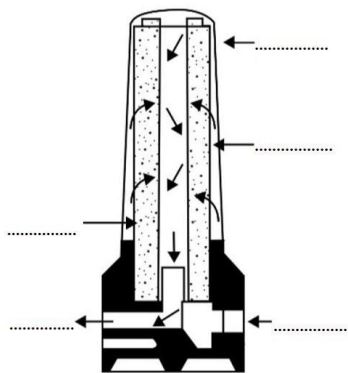
The water is passed into a closed reservoir containing disinfectants such as chlorine. These disinfectants kill the bacteria or microorganisms present in the water. The purified water then flows through pipes to homes.



*Fig.4.24: Disinfection*

**Activity: Identification Game**

Label all the parts of standard carbon black filter in the following image.



*Fig.4.25*

## 4.5 DIFFERENT TECHNOLOGIES IN WATER PURIFICATION

### 4.5.1 Water Purifiers

Pure, clean and safe drinking water is a necessity for human life and health. Water that is supplied in homes is contaminated with organic and inorganic particles. It becomes critical to purify the tap water to ensure it is safe for consumption. Also to make sure it must have any adverse effect on health. A water purifier removes contaminants such as excess salts, suspended particles and microbes dissolved in water. In purification it preserves the necessary vitamins and minerals of water. The following image shows a common water purifier:



Fig.4.26: A water purifier

### 4.5.2 Types of Water Purifier

There are five major categories of water purifiers, depending on the purification methods they use. The following figure lists these categories:

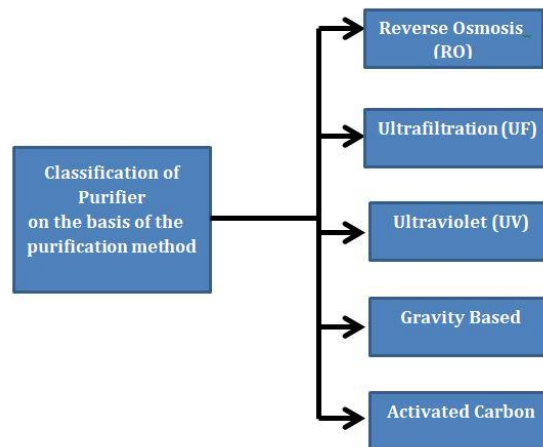


Fig.4.27: Types of purifiers

#### 1. RO Water Purifiers

RO water purifiers are the most commonly used purifiers and is based on the principle of reverse osmosis. They make use of the membrane technology to eliminate contaminants such as salts, heavy metals and germs dissolved in water. The following image shows an RO purifier membrane:





**Fig.4.28: An RO purifier membrane**

The main advantages of using an RO purifier are as follows:

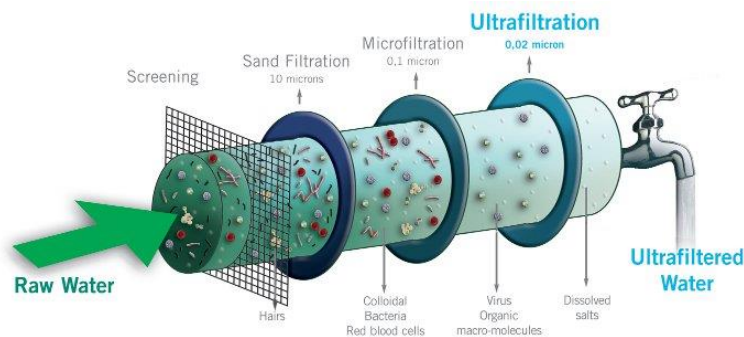
- Removes impurities such as lead, arsenic, mercury and germs from water
- Environmental friendly
- Suitable for hard water
- Suitable for water with high total dissolved salts (TDS)
- Easy to install and maintain

There are certain disadvantages of an RO purifier such as:

- Removes essential minerals along with dissolved impurities
- Change the taste of water
- Wastes large quantity of water
- Requires electricity to purify water
- Requires special care and maintenance for its membrane

## 2. UF Water Purifiers

UF water purifiers use membranes similar to an RO membrane but with larger pores. They remove all germs and bacteria from water but do not remove dissolved salts or solids. They are suitable in homes where the water supplied is not very hard and has less dissolved salts. The process of purification in a UF purifier is shown in the following image:



**Fig.4.29: Process of purification in a UF purifier**

Courtesy: <http://bit.ly/2Aey7gV>

The main advantages of using a UF purifier are as follows:

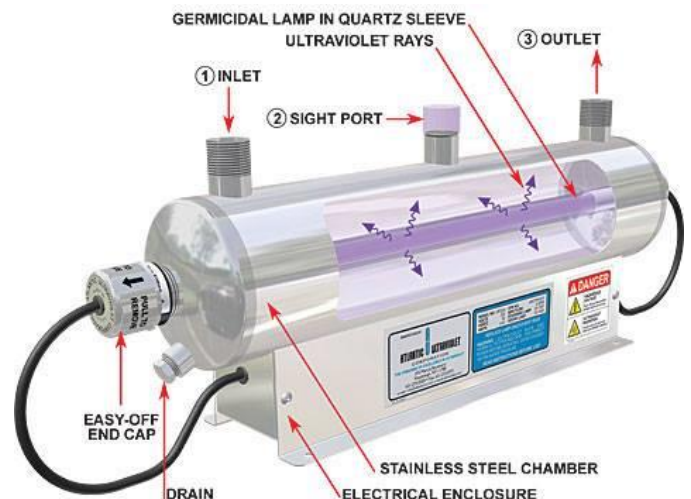
- Removes impurities and germs from muddy water
- Environmental friendly
- Does not require electricity to purify water
- Retains the taste and odor of water
- Easy to install and maintain

There are certain disadvantages of a UF purifier such as:

- Unable to remove dissolved impurities such as arsenic, lead, nitrates and fluorides
- Ineffective as compared to an RO water purifier as it cannot block dissolved salts and solids
- Good only for water with low TDS

### 3. UV Water Purifiers

UV water purifiers use ultraviolet rays to kill all germs, bacteria and microbes dissolved in water. A small mercury lamp is placed inside the purifier, which produces high frequency short wave UV radiations. When water passes through this element, it is exposed to the UV light which kills all the living organisms. Separate filters then remove the dead germs. UV purifiers are used in residences, breweries, water stores, restaurants and municipalities. The following image shows the working of UV water purifiers:



*Fig.4.30: UV water purifier*

The main advantages of using a UV purifier are as follows:

- Removes viruses, bacteria and germs from water
- Environmental friendly
- No chemicals added to water
- Retains the taste and odor of water
- Easy to install and maintain

There are certain disadvantages of a UV purifier such as:



- Unable to remove dissolved impurities such as arsenic, lead, nitrates and fluorides
- Requires electricity to purify water

#### 4. Gravity Based Water Purifiers

Gravity based water purifiers are based on the principle of gravity. The water flows from a higher compartment over the filters to a lower compartment. They do not require electricity and use either chemical based, UF based or ceramic cartridge based filters to purify water.

The following figure shows the part of a gravity based purifier:



*Fig.4.31: A gravity based purifier*

The main advantages of using a gravity based purifier are as shown in the following:

- Removes impurities and germs from muddy water
- Environmental friendly
- Does not require electricity to purify water
- Suitable for soft water
- Portable and easy to install

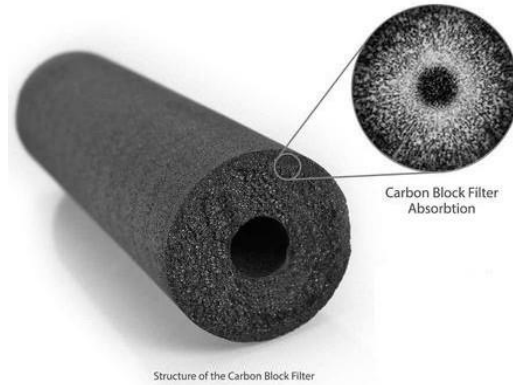
There are certain disadvantages of a gravity based purifier such as:

- Unable to remove dissolved impurities such as arsenic, lead, nitrates and fluorides
- Ineffective as compared to an RO water purifier as it cannot block dissolved salts and solids
- Good only for water with low TDS

#### 5. Activated Carbon Water Purifiers

Activated carbon is carbon with a positive charge added to it. When water flows over it, the negative ions of contaminants get attracted to the surface of the activated carbon filter. Activated carbon water purifiers can remove volatile organic compounds, pesticides, herbicides, chlorine and other chemicals found in tap water. This makes the water safe to drink.

The following images show the process of purification in an activated carbon water purifier:



**Fig. 4.32: An activated carbon block filter**

**Activity: Identification Game**

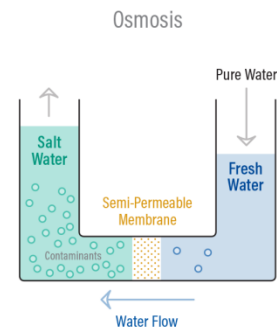
**Match the following.**

|                                     |   |
|-------------------------------------|---|
| 1. Gravity Based Water Purifiers    | a) Removes impurities such as lead, arsenic, mercury and germs from water |
| 2. UV Water Purifiers               | b) Removes volatile organic chemicals, radon and chlorine                 |
| 3. RO Water Purifiers               | c) Removes viruses, bacteria and germs from water                         |
| 4. Activated Carbon Water Purifiers | d) Removes impurities and germs from muddy water                          |

**4.5.3 DIFFERENT FEATURES AND FUNCTIONALITIES OF PURIFIER**

**a) RO Water Purifier**

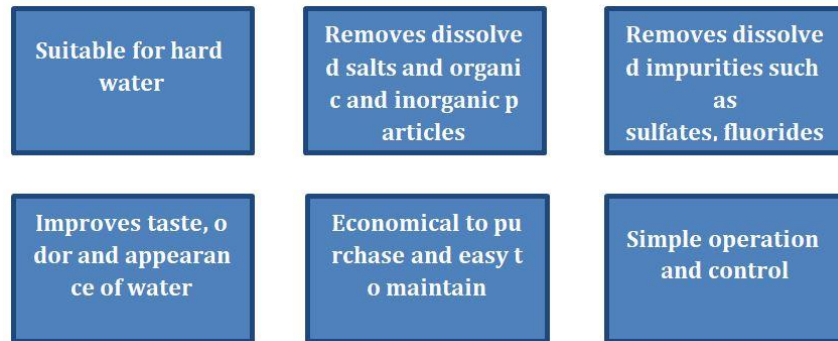
RO water purifiers work on the principle of Reverse Osmosis (RO). In this process, pressure is applied on contaminated water to force it through a semi-permeable membrane. The water is purified by filtering and flushing out the impurities as shown in the following image:



**Fig.4.33: Reverse osmosis process**

## b) Properties of RO Water Purifier

The properties of an RO water purifier are shown in the following figure:




*Fig.4.34: Properties of an RO water purifier*

## c) Component of RO Water Purifier

The following table lists the basic components of an RO system:

|  |  |
|--|--|
| Supply line valve<br><i>Fig.4.35(a)</i>      | Attaches the inlet of the RO pre-filter to the water source through a tube                         |
| Pre-filter<br>Sediment<br><i>Fig.4.35(b)</i> | Removes sand, dirt and other sediments   |
| Carbon filter<br><i>Fig.4.35(c)</i>          | Absorbs chemical impurities such as chlorine and pesticides and improves odor and taste of water   |
| RO membrane<br><i>Fig.4.35(d)</i>            | Removes almost all dissolved salts, impurities and bacteria  |
| Water tank<br><i>Fig.4.35(e)</i>             | Stores water before 'post filtration'  |
| Post filter<br><i>Fig.4.35(f)</i>            | Also known as 'polishing' filter as it removes the remaining taste and odor from the treated water |
| Shut-off valve<br><i>Fig.4.35(g)</i>         | Automatically shuts-off the water supply to the membrane when the storage tank gets full           |
| Check valve<br><i>Fig.4.35(h)</i>            | Prevents backward flow of water from the tank to the membrane                                      |
| Flow restrictor                              | Maintains pressure on the inlet of the membrane to ensure  |

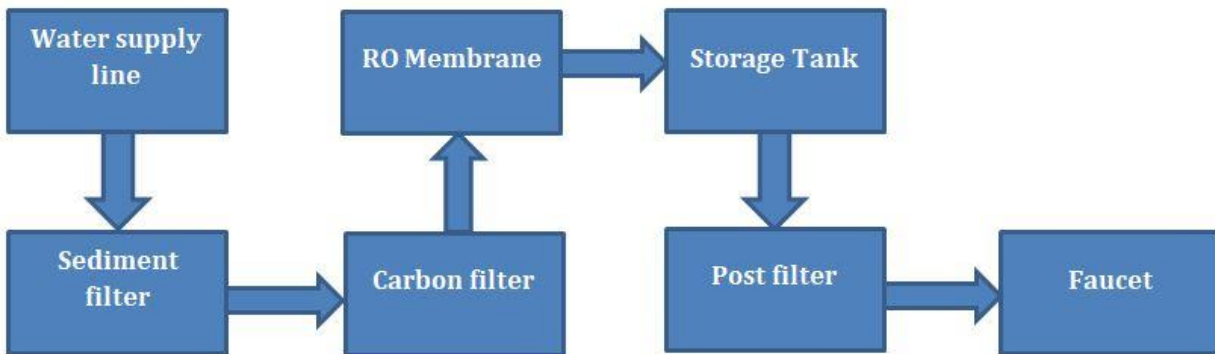
|  |   |
|--|---|
| <i>Fig.4.35(i)</i>   | re the highest quality of water   |
| Drain line<br><i>Fig.4.35(j)</i>   | Connects one outlet of the membrane to the drain to dispose off waste water |
|  |   |
| <i>Fig.4.35: Components of an RO water purifier</i>                                |   |

#### **d) Functioning of RO Water Purifier**

The following steps explain the functioning of an RO water purifier:

|              |   |
|--------------|---|
| <b>Step1</b> | Water enters from the supply line   |
| <b>Step2</b> | Water enters the sediment filter which strains out sand, dirt and sediments           |
| <b>Step3</b> | Water enters the carbon filter which removes chlorine and other contaminants          |
| <b>Step4</b> | Water enters the RO membrane which filters out all additional contaminants            |
| <b>Step5</b> | Water enters the storage tank<br><br>Waste water containing impurities is drained out |
| <b>Step6</b> | Water enters post filter to remove any remaining odor and taste in water              |

|              |  |
|--------------|--|
| <b>Step7</b> | Water leaves the filter and goes to faucet |
|--------------|--|



*Fig.4.36: Functioning of an RO water purifier*

**Activity: Role Play**

A customer asked you to tell the components of RO Water Purifier. List all the components that you will tell her/him.

**Practical activity:** Visit the site and identify the place for installation.

**Role play:** Suppose, you got a call regarding the installation of the purifier. List the factor which has to be considered for while selecting the site for installation.

**Practical activity:** Maintaining adequate water pressure at the inlet source.

For maintaining of suitable pressure in the inlet of purifier following steps has to be considered:

Apparatus required: Pressure gauge, pipe , pressure regulator

Procedure:

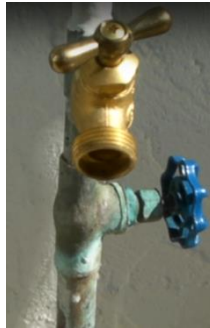
1. To measure the pressure of water flowing in the pipe of water purifier, firstly turn off water supply.

2. Locate the main water supply, there is threaded spigot.



*Fig.4.37*

3. This spigot has a valve or a lever next to it.



*Fig.4.38*

4. Screw the end of the pressure gauge in the threaded spigot.



*Fig.4.39*

5. Twist the valve to turn ON the water supply in the pipe.



*Fig.4.40*

6. This will allow water to flow through the spigot and will give you a reading on your pressure gauge.



*Fig.4.41*

7. The needle on the gauge should move to a number that represents your water pressure in pounds per square inch or PSI.



**Fig.4.42**

8. Note down the reading on the pressure gauge.



**Fig.4.43**

9. The average pressure for the purifier is 50-70 psi (Pound per inch).

10. If the reading is greater than this average value of pressure. Release the pressure using pressure regulator to the appropriate value.



**Fig.4.44**



**Practical activity:** Make necessary markings for placement of the water purifier unit.

Following steps has to be considered for the marking of water purifier unit:

**Practical activity:** Demonstrate the point that has to consider for the site inspection and preparation.

Following Points has to be in mind while selecting the site for the installation of water purifier:

1. Locating the water purifier near a source of water
2. Locating the water purifier near an electrical point.
3. Make sure socket through which purifier is going to be powered should have earthing.
4. Distance between the purifier and the water source should be within 3 m.
5. Distance between the purifier and the electrical supply should be within 3 m.
6. Distance between the purifier and the drainage system should be within 3 m.
7. Keep the purifier away from direct heat or sunlight.
8. Remember that there are needs to change the membrane periodically, keeping in mind this step; select a location in which membrane can be easily replaced.
9. If there is an issue of space, purifier can be mounted on the wall.

## **4.6 INSTALLATION PROCEDURE**

### **4.6.1 Specification for installation of water purifier**

#### **1. System location**

The RO system should be located on a level surface. The area where water purifier is going to be installed must be sheltered from sun, wind and rain. The temperature in this area should be maintained, and should not fall below 35 F,

or greater than 95 F. If these limits are exceeded, damage to components may result and the warranty may be considered void. It is important to allow sufficient space around the unit so maintenance can easily be performed.

## **2. Plumbing**

The membranes and high pressure pumps used require a continuous and stable flow of water to the system. Please refer the manual for minimum flow rate and minimum feed pressure.

## **3. Feed water**

Piping used for feed water to the RO system should be either copper or plastic. Iron and carbon steel pipe will increase the iron content of the feed water. This will adversely affect the RO system's performance. Temperature of the feed water must not exceed 95 F.

Important: It is recommended to install a pressure gauge on the feed water line. This will help to maintain the pressure of the feed water.

## **4. Concentrate (waste) line connection**

Connect the waste line to the back side of the system. The tubing or piping used for discharge of the concentrate should be run to an open drain in a free manner. Any blockage in the drain can cause backpressure, which will increase the system operating pressure. This may result in damage to the system components.

## **5. Electrical supply**

A properly sized electrical service must be provided by the customer. Motors and electrical requirements must be according to the supply voltage. Electrical supply to the system must be compatible with the requirements for each model. Install system in accordance with local and national electrical codes.

## **6. Pre-filtration**

Most RO systems come with particulate pre-filters to remove suspended particles down to five (5) micron in size. Change pre-filter cartridges at least every month. Additional pretreatment may be required, depending on feed water parameters.

### **Caution:**

If the pre-filters become blocked and the water flow to the pump is reduced or interrupted. This will result in the formation of an empty space with in a pipe. This may damage the pump.

## **7. Inspections**

Prior to start-up, carefully inspect system. Check plumbing, electrical connections and make sure no connections have become loose during shipment.

#### 4.6.2 Guideline for the installation of water purifier

The following figure lists the guidelines that should be followed before installing an RO water purifier:

- Avoid exposure to direct sunlight or heating devices
- Avoid placing the rejected water pipe at a higher level than the purifier
- Avoid sharp bends in the pipe
- Avoid bending or blocking the rejected water pipe
- Ensure that the purifier is connected to the normal water supply only
- Ensure that the purifier is installed within 3 meters of the water source
- Avoid confining the purifier in a cabinet

*Fig.4.45: Pre- installation guidelines*

The installation process begins with site preparation. The recommended site preparation steps are shown in the following:

|  |
|--|
| Ensure single phase connection is within 3m of the point of installation |
| Ensure raw water supply is within 3m                                     |
| Ensure raw water supply tank is at least 10 feet above the purifier      |
| Ensure there is a sink near the purifier                                 |
| Ensure waste water drain is within 3m                                    |
| Ensure enough space is there as per the dimensions of the purifier       |

The following steps should be performed when installing RO water purifier:

**STEP1: UNPACKING OF THE PURIFIER**

1. Carefully place a water purifier packing box on the plane surface.



**Fig.4.46:**

2. Cut the packing strips on the packing box with the help of knife.



**Fig.4.47:**

3. Open the water purifier packing box.



**Fig.4.48**

4. Take out all the accessories from the packing box.



**Fig.4.49:**

5. Take out RO water purifier from the packing box carefully.



**Fig.4.50:**

6. Place the water purifier on the plane surface.



**Fig.4.51:**

7. Remove the thermocol packing and remove the polythene cover from the water purifier.



**Fig.4.52:**

**Practical activity:** Remove the packaging of water purifier and dispose the packaging material waste as per norms.

Write the steps to unpack the water purifier and discuss the precaution has to be taken while un-packaging the water purifier. Also discuss the dispose packaging material waste as per norms.

#### **Items in the box**

- Water purifier
- 3 way connector
- SS ball valve
- Grade pipe (white and blue)
- Screw and plastic inserts
- Instruction manual
- Drilling sticker

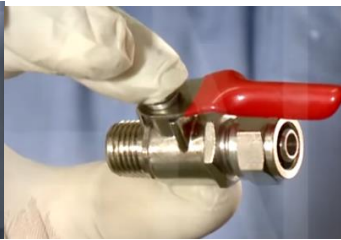


**Fig.4.53: (a)**





**Fig.4.53:(b)**



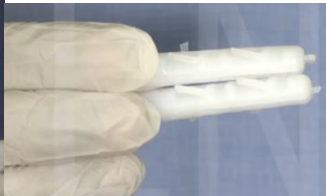
**Fig.4.53:(c)**



**Fig.4.53:(d)**



**Fig.4.53:(e)**




**Fig.4.53:(f)**



**Fig.4.53:(g)**

**Practical activity:** Check that the product specifications and other supporting accessories.

List the items which are present in the box and note it down their specification.

| Items in the box   | Name         |
|--|--------------|
|  <p><b>Fig.4.54</b></p> | <p>.....</p> |



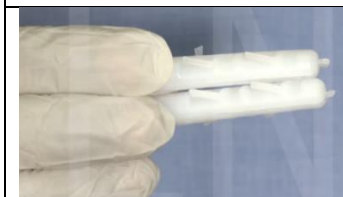
**Fig.4.55**

.....



**Fig.4.56**

.....



**Fig.4.57**

.....



**Fig.4.58**

.....



**Fig.4.59**

.....

**Practical activity:** Arrange tools and fitments required for the installation. List the tools required for the installation and maintenance of the water purifier.



| Tool and equipment   | Name         |
|--|--------------|
|  <p><b>Fig.4.60</b></p>   | <p>.....</p> |
|  <p><b>Fig.4.61</b></p>   | <p>.....</p> |
|  <p><b>Fig.4.62</b></p> | <p>.....</p> |
|  <p><b>Fig.4.63</b></p> | <p>.....</p> |



**Fig.4.64**



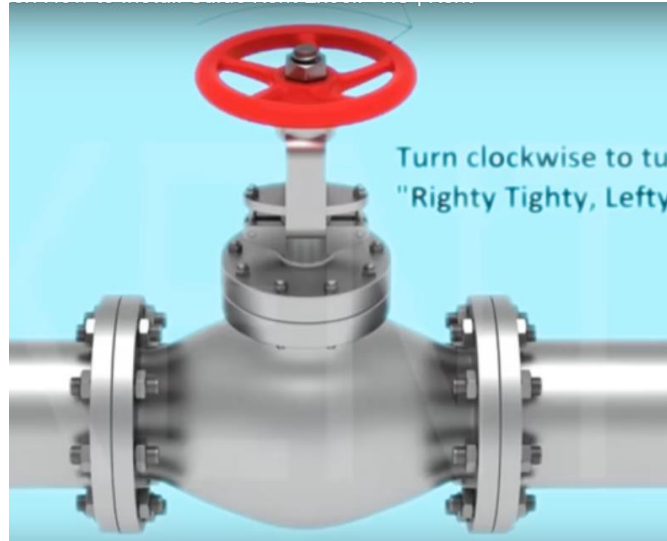
**STEP2: SETTING UP THE WATER CONNECTION**

1. Keep all the plumbing accessories and tools ready before turning off the main water supply line, so that it gets interrupted for a minimum time.



**Fig.4.65:**

2. Turn off the main supply line.



*Fig.4.66:*

3. Always install purifier on the normal water supply and not on the hot water supply.



*Fig.4.67:*

4. Take out the tap from water supply line carefully, using pipe wrench.



**Fig.4.68:**

5. 3 way connector with an external thread.



**Fig.4.69:**

6. Use a Teflon tape to create a leak-free joint.



**Fig.4.70:**

7. It should be wrapped tightly on a 3 way connector in a clockwise direction only otherwise it may loosen during tightening on water supply line.



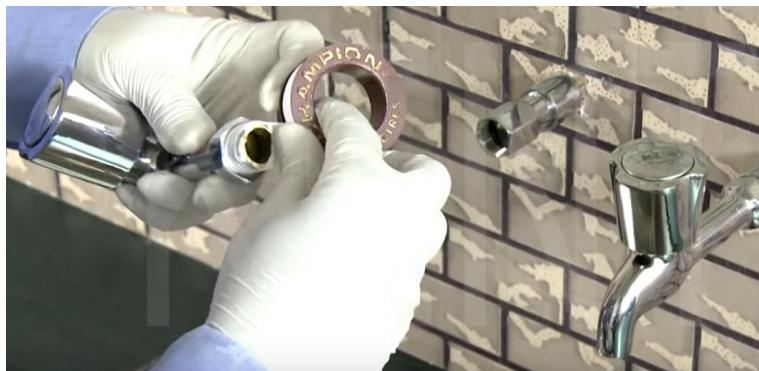
**Fig.4.71:**

8. Insert external thread end of the 3 way connector into the water supply line.



**Fig.4.72:**

9. Use Teflon tape on the tap to create a leak free joint.



**Fig.4.73:**

10. Now insert the tap into the hex end of the three way connector and tighten it using pipe wrench.





**Fig.4.74:**

11. Use SS ball valve; use Teflon tape again on the SS ball valve thread to create a leak free joint.



**Fig.4.75: (a)**

**Fig.4.75: (b)**

12. Insert the SS ball valve into the ¼ inch port of the 3 way connector.



**Fig.4.76:**

13. Take a white pipe broaden it up its mouth from one end by inserting a screw driver into it.



**Fig.4.77:**

14. Move a hex nut present on the SS ball. Insert this hex nut into the white pipe from the non-broadened end.



**Fig.4.78:**

**Fig.4.78: (b)**

15. Push the broaden end of the white pipe onto the SS ball valve. Make sure that pipe completely slips over the nipple of SS ball valve.



**Fig.4.79:**

16. Tighten securely the hex nut on the SS ball valve to lock the pipe in its place.



*Fig.4.80:*

17. The water supply remains OFF when the lever is perpendicular to the SS ball valve body.



*Fig.4.81:*

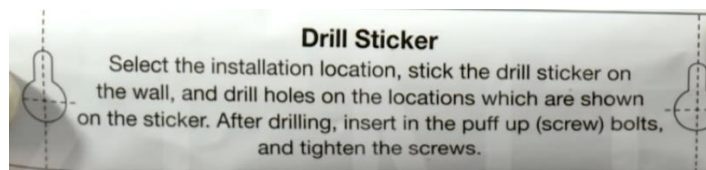
18. The water supply remains ON when the lever is parallel to SS ball valve body.



*Fig.4.82:*

### **STEP3: MAKING PREPARATION TO MOUNT THE PURIFIER**

1. Every purifier has a drilling sticker with measured marking.



*Fig.4.83:*

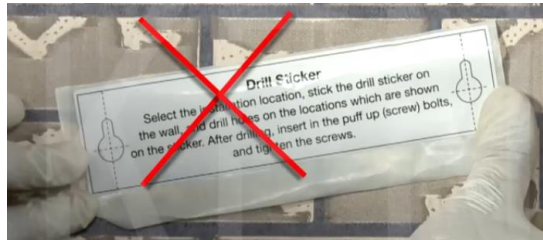
2. Check for the proper horizontal level which should be plane even surface.





**Fig.4.84:**

3. The drilling sticker not be pasted inclined as water may overflow.



**Fig.4.85:**

4. Stick the drilling sticker in a proper horizontal straight line.



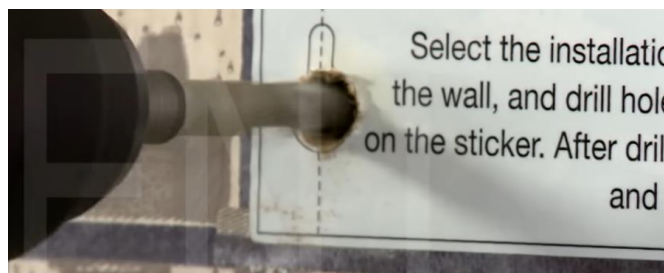
**Fig.4.86:**

5. Drill carefully two holes into the sticker making using the 8 mm drill bit.



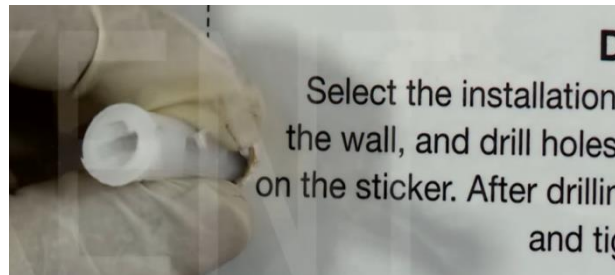
**Fig.4.87:**

6. Drill to such a depth that the plastic inserts could go completely inside the hole.



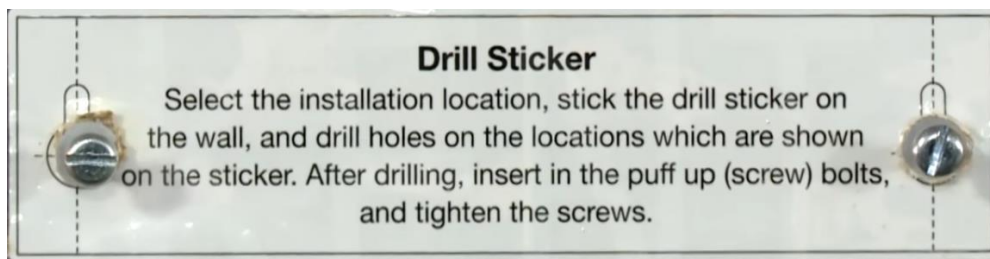
**Fig.4.88:**

7. Push plastic inserts into the hole using a hammer.



*Fig.4.89:*

8. Insert two self-taping screws in both the holes using screwdriver. Do not uses hammer.



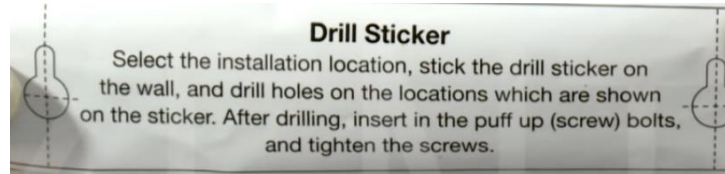
*Fig.4.90:*

**Practical activity:** Before starting the installation, check whether the pre-installation requirements are fulfilled.

**Practical activity:** Make measurements and drill holes without damage internal wiring.

Following steps has to be considered while performing drill practice.

1. Firstly when technician unpack the purifier, she/ he will find the drill sticker in the box of purifier.



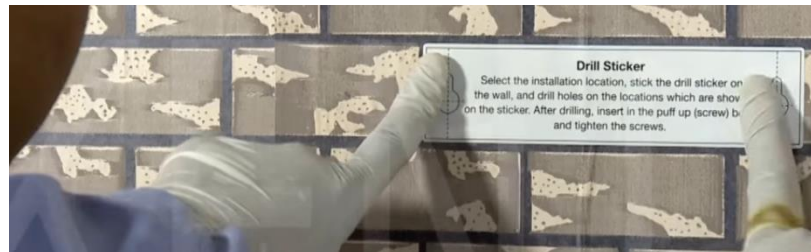
*Fig.4.91*

2. Use this drill sticker for the horizontal alignment of the water purifier.



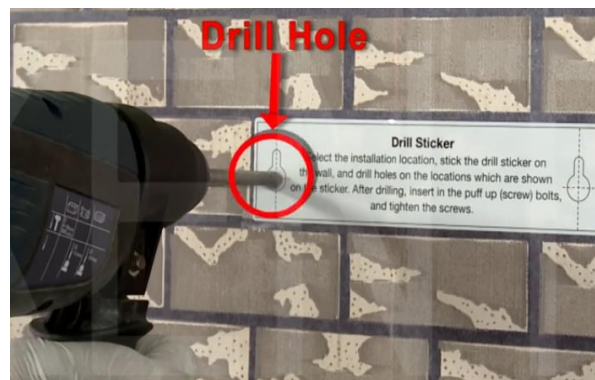
*Fig.4.92*

3. Stick the drilling sticker in a proper horizontal straight line.



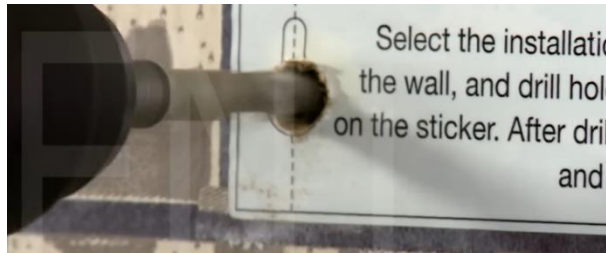
*Fig.4.93*

4. Drill carefully two holes into the sticker making using the 8 mm drill bit.



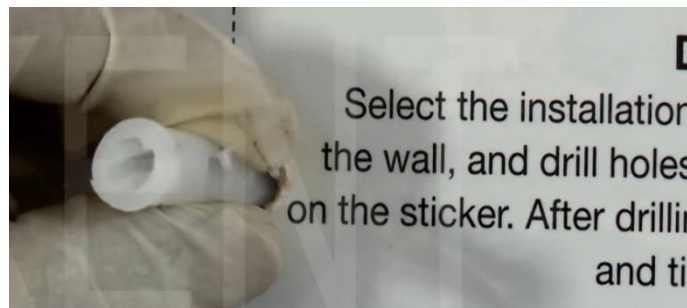
*Fig.4.94*

5. Drill to such a depth that the plastic inserts could go completely inside the hole.



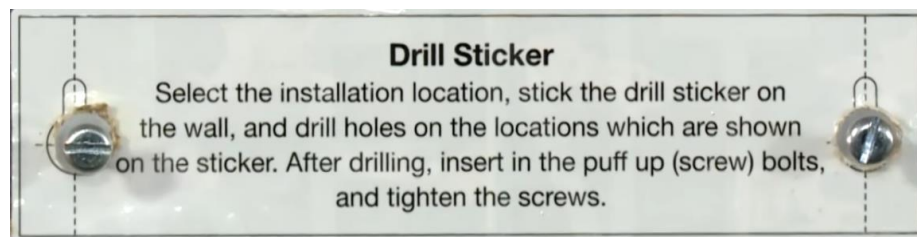
*Fig.4.95*

6. Push plastic inserts into the hole using a hammer.



*Fig.4.96*

7. Insert two self-taping screws in both the holes using screwdriver. Do not use hammer.



*Fig.4.97*

**Practical activity:** Demonstrate the steps for the installation of filter as per the installation guide.

Following steps shows the installation of filters:

1. First step to install filter is to turn off the water supply.
2. Next, open a tap to release any remaining water in the line and the pressure in the pipes.
3. Select a location to set up the filter.

4. Mark the spot where you are going to install filter.
5. Selected location should be visible and accessible.
6. Make two cuts and remove part of the pipe.
7. But, before removing the cut piece of the pipe, make sure that bucket is kept nearby to catch any water that may not have been drained.
8. Now, tighten the fittings but do not tighten too much..
9. Now that the fittings are installed, the next step is to install the filter. When you place it on the pipe, you have to ensure that it is positioned on the right side and not backward.
10. If filter is working properly, leave the pipe running for several minutes.
11. Sometimes, there may be dirt and sediments in the pipe that need to come out.
12. Once these are expelled and water appears clear, then it is safe for drinking and consumption.

**Practical activity:** Write down the steps, while installing the inlet water supply line before connecting it to the water purifier.

**Hand tools required:** Bucket, Adjustable wrench, Pipe cutter

Following point illustrate the steps for the installation of inlet supply to the water purifier:

1. Drain the System by turning off the water supply.
2. Now, release the pressure from the lowest point of the water supply system.
3. Drain the remaining water from that lowest point of the water supply system.
4. Locate the place of purifier, once it is finalized. Cut the pipe as per the measurement.
5. Use the template provided with the kit to mark the pipe for exact placement.
6. Attach the Fittings
7. Check the water pressure using pressure gauge.

**Practical activity:** Discuss the power requirement of the water purifier.

**Hint:** Point to be discuss are as follows:

Input voltage of power supply: .....

Output voltage of power supply: .....

Current capacity of power supply: .....

Operating frequency of power supply: .....

Overload protection: .....

Over temperature protection: .....

#### **STEP4: INSTALLING THE PURIFIER**

1. Place the purifier on a flat surface and remove transparent tank tray of the purifier, front transparent tank.



**Fig.4.98:**

2. Remove mounting plate cover by opening the three side screw as well as two side screws.



**Fig.4.99:**

3. Cut the tie wires holding the sediment filter, activated carbon block, RO membrane housing and UV chamber in place.





**Fig.4.100:**

4. These components are so tied as to save them getting damaged or dislocated from their position during transportation.



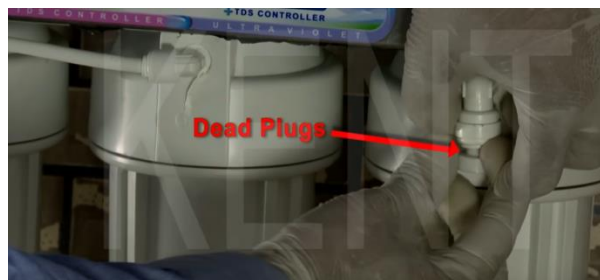
**Fig.4.101:**

5. Fix the mounting plate cover back.



**Fig.4.102:**

6. Remove dead plug from rejected water outlet by pressing elbow collet with one hand and pulling the dead plug with the other.



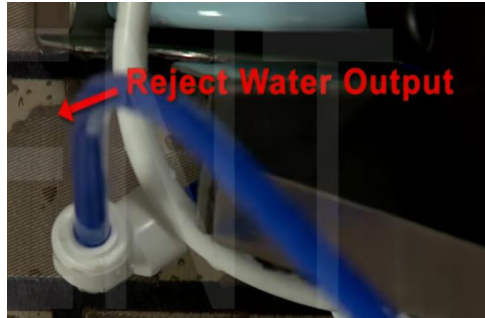
**Fig.4.103:**

7. Remove dead plug from raw water inlet by pressing elbow collet with one hand and pulling the dead plug with the other.



**Fig.4.104:**

8. Fix one end of the blue pipe into rejected water outlet of water purifier. Push the pipe into the elbow to avoid any leakage.



**Fig.4.105:**

9. Lead the other end of the blue pipe into the drain.



**Fig.4.106:**

10. Fix the end not fixed to SS ball valve of the white pipe into the water inlet of water purifier.





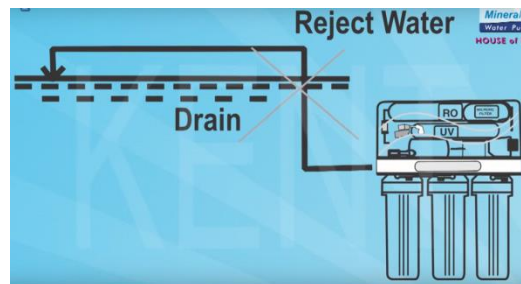
**Fig.4.107 (a):**      **Fig.4.107 (b):**

11. Clamp both white and blue pipe on the flat surface.



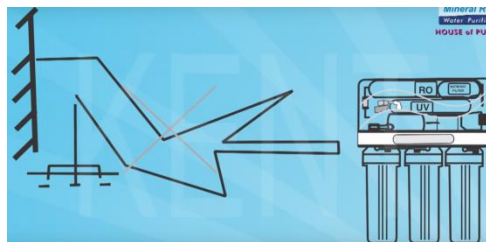
**Fig.4.108:**

12. Make sure that the rejected water pipe is not placed at a level higher than the purifier, otherwise the rejected may flow backward into the purifier.



**Fig.4.109:**

13. Avoid sharp turns in the pipe fitting. Do not bend or block the rejected water pipe.



**Fig.4.110:**

14. Put the transparent tank as well as tank tray on the mounting plate cover.



**Fig.4.111:**

15. Insert the power plug into the three pin socket. Clamp the electric cable on the wall.



**Fig.4.112:**

16. Turn ON the water supply with the help SS ball valve lever.



**Fig.4.113:**

17. The water supply remains OFF when the lever is perpendicular to the SS ball valve body.



**Fig.4.114:**

18. The water supply remains ON when the lever is parallel to SS ball valve body.



**Fig.4.115:**

19. Wait for 2-3 minutes after turning on the water supply to pre-soak the filters.



**Fig.4.116:**

20. Switch the electric supply.



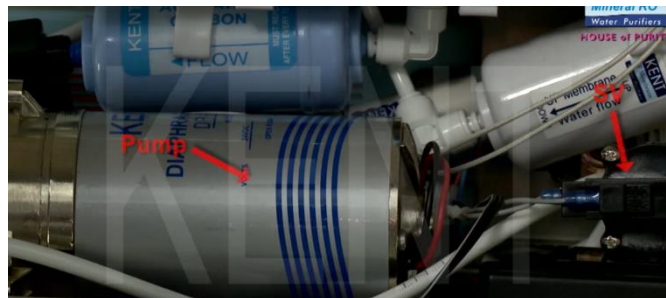
**Fig.4.117:**

21. UV lamp will take three second to glow to ensure that it is pre-heated and it is working at its optimum level before it starts disinfecting water.



**Fig.4.118:**

22. SV and pump will start operating after 5 seconds of the glowing of UV lamp to ensure that the idle water lying in the internal pipes and in the UV chamber is disinfected before being passed in the storage tank.



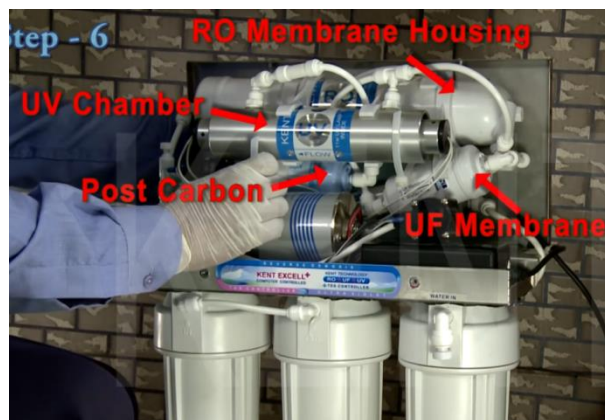
**Fig.4.119:**

23. To check the leakage shift the mounting plate cover.



**Fig.4.120:**

24. Take out post carbon outlet pipe, check and fix the leakage, if any.



**Fig.4.121:**

25. After checking the leakage, place the mounting plate cover on its previous position.



**Fig.4.122:**

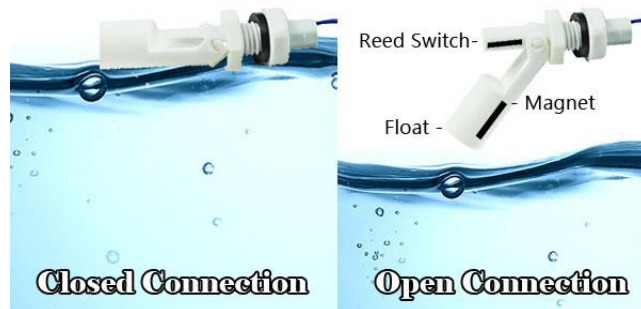
26. Let the purifier operate till the storage tank gets filled.





**Fig.4.123:**

27. The purifier shut off automatically. This show float sensor is working properly or not.



**Fig.4.124:**

28. Switch off the purifier. Completely drain the storage tank into a container because the first few liters of water purified by the RO membrane are not fit for the drinking water.



**Fig.4.125:**

29. Recheck the TDS (Total dissolved solid) level of raw water supply (TDS level – 974 PPM).



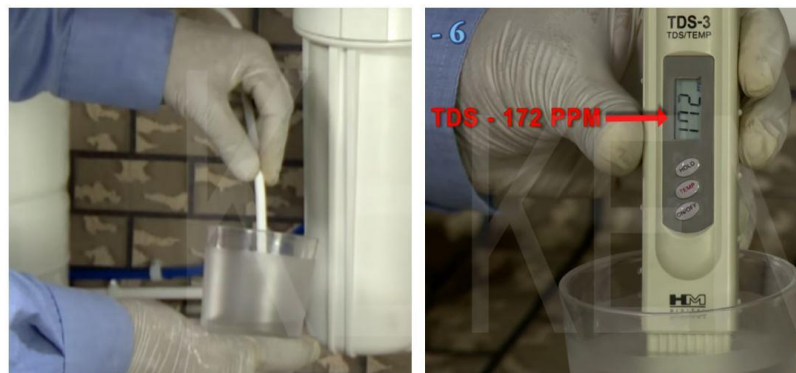
**Fig.4.126:**

30. Check the TDS level of the water coming out from the outlet of the post carbon filter and not the tap water.



**Fig.4.127:**

31. The purified water level should reduce by approximately 90% of raw water TDS and should not be less than 50 PPM.



**Fig.4.128:**

32. The recommended TDS level is 50-75 PPM. However it could be adjusted to the customer's choice of raw water TDS.



**Fig.4.129:**

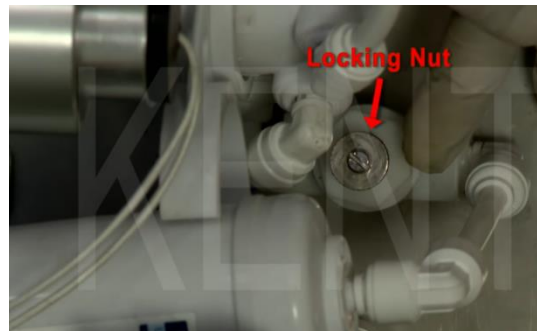
**STEP5: ADJUSTING TDS LEVEL**

1. First remove transparent tank as well as mounting plate cover.



**Fig.4.130:**

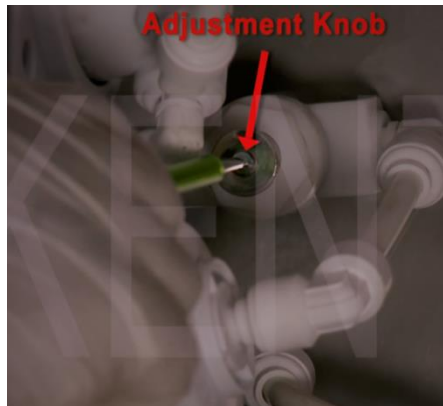
2. To adjust the TDS levels unscrew the locking nut first.



**Fig.4.131:**

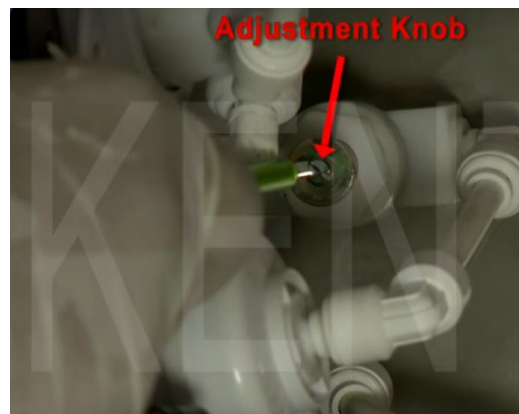


3. To increase the TDS level of the purified water, slightly turn the adjustment knob in the anti-clockwise direction.



**Fig.4.132:**

4. To decrease the TDS level of the purified water, slightly turn the adjustment knob in the clockwise direction.



**Fig.4.133:**

5. After adjustment screw the locking nut.



**Fig.4.134:**

6. The adjustment roughly take 3-4 minutes to reflect in the purified water, so wait before checking the TDS level of the purified water.



**Fig.4.135:**

7. Recheck over all functioning of the purifier and also any leakage, sound, etc.



**Fig.4.136:**

8. Now fix the mounting plate by screwing all the screws taken out earlier.



**Fig.4.137:**

9. Before leaving clean the stains on the purifier with a moist cloth and mild soap or detergent.



**Fig.4.138:**

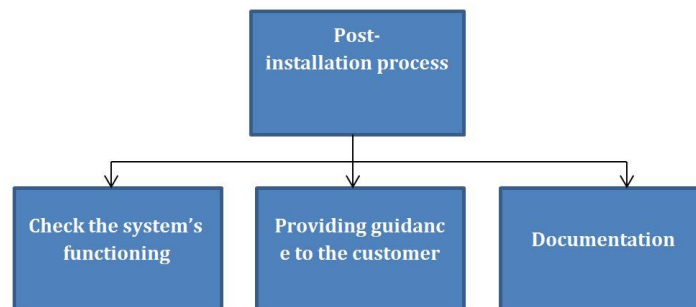
10. Installation is now complete.



**Fig.4.139:**

#### **4.7 POST-INSTALLATION PROCESS OF RO WATER PURIFIERS**

Once the purifier has been successfully installed, it is time to follow the post-installation process to ensure completion of the installation process. The post-installation process consists of tasks as shown in the following *figure*:



**Fig.4.140:**

##### **4.7.1 Checking the Function of System**

Perform the checks as shown in the following figure to ensure that the purifier is working properly:

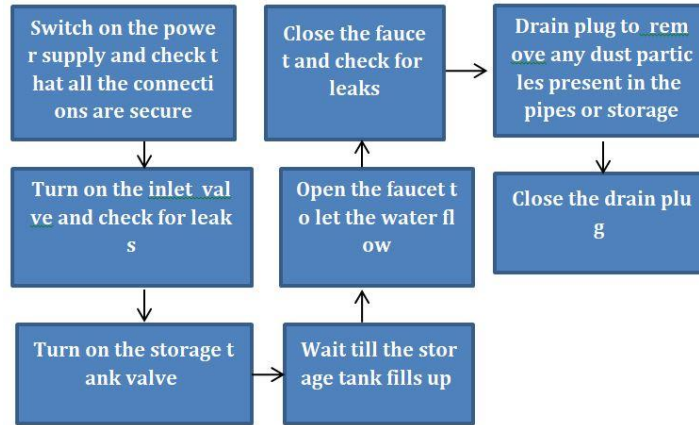


Fig.4.141: Checks to ensure proper working of an RO purifier

#### 4.7.2 Providing Guidance to the Customer

After installing the purifier, the field technician should give a demonstration of the working of the purifier. It is a way of promoting or showing the operation of purifier to the users. The goal of demonstrating is to show the customer how to operate and use the purifier. There are a few rules which must be considered while preparing for the demo.

The following point list out these rules:

- Customize your demo.
- Rehearse before presenting.
- Test everything beforehand.
- Take customer feedback.

#### 4.7.3 Inform the Customer about the Dos and Don'ts of Maintenance

Inform the customers that an RO water purifier lasts for many years if it is maintained properly. The following figure shows the various Dos and Don'ts that should be followed:

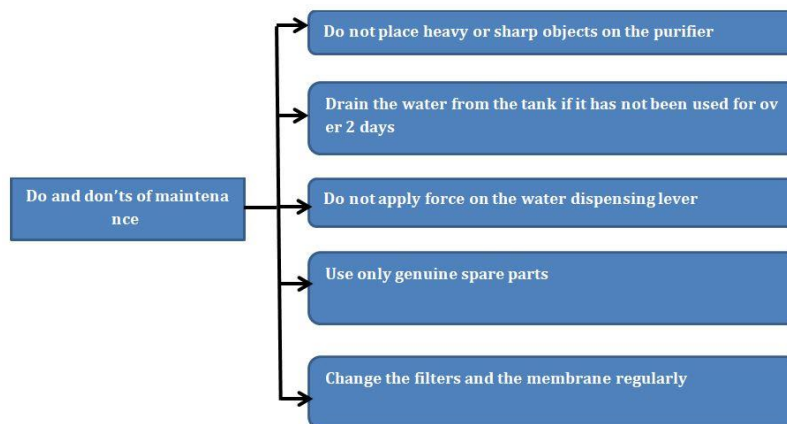


Fig.4.142: Do and don'ts of maintenance

**Practical activity:** Demonstrate the steps for checking the filter installation alignment as per instructions in the installation manual.

**Practical activity:** List the point where leakage can occur in the purifier. Also discuss the steps to identify the leakage in the purifier.

**Hint:** Point where probability of leakage is high are as follows:

- At the inlets of water supply.
- At the joint of pressure gauge and main water supply pipe.
- At the joint of carbon filter, sediment filter, membrane filter.
- At the joint of drainage pipe.
- At the faucet.
- At the joint of water tank

**Practical activity:** Demonstrate the steps which technician must explain to the customer after completion of installation.

Following points must be explained to the customer :

1. Do not place heavy or sharp object on the purifier.
2. Replace the water of purifier after a day.
3. Do dusting at regular interval.
4. Periodically monitor the pressure gauge.
5. Use genuine spare parts in case of replacement.
6. Change the membrane and filter regularly.
7. Check the specification of power supply.
8. Periodically check the total dissolved solid (TDS) of water.

**Practical activity:**

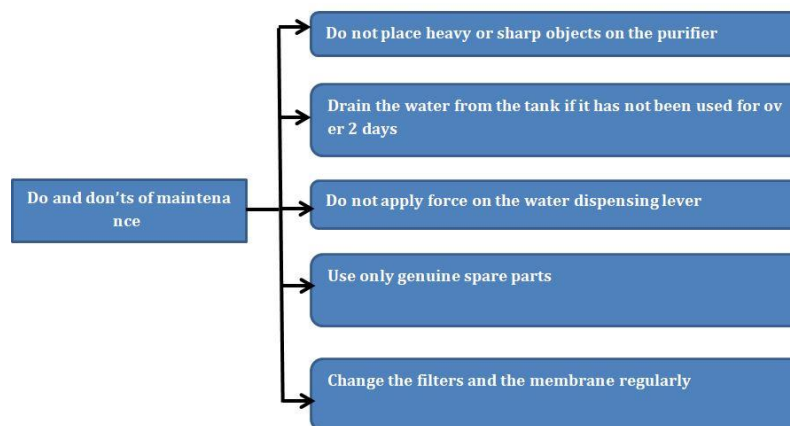
**Role play:** Suppose, you are a water purifier technician after completion of installation. What points you must communicate to the customer for the maintaining the water purifier.

**Practical activity:** Visit the nearby installed purifier assembly note down the desired standard parameters such as the water pressure, power supply, connection as per the water flow diagram.

## 4.8 DOCUMENTATION REQUIRED IN THE INSTALLATION OF WATER PURIFIER

### 4.8.1 Documentation

The last task of the post-installation process is to fill in all the details in the installation report clearly and get feedback from the customer. *Figure 4.143* shows a typical template of the installation form that the field technician should fill-in after installing an RO system:



*Fig.4.143: A sample installation report*

### 4.8.2 Customer acknowledgment form

Customer acknowledgement form is the documentation in which feedback of customer is taken. Acknowledgement form act as a documental proof of getting served by the water purifier executive at the customer premises. This defines the satisfactory service of the executive to the customer. Every company has their own format of acknowledgement form.

### 4.8.3 Call centre number

Customer care is the monitor and complaint registering authority of the company. A customer can directly contact to the company to file their complaint and give feedback. Customer care is bridge between the customer and company.

| RO Customer Service Locations | Contact number |
|-------------------------------|----------------|
|-------------------------------|----------------|

|                            |  |
|----------------------------|--|
| Service number             |  |
| Complaint number           |  |
| Toll free number           |  |
| RO call centre number      |  |
| RO help line number        |  |
| RO customer service number |  |

**Practical activity:** Understand and discuss the parameters mentioned on the customer acknowledgment form. Also discuss the need of customer acknowledgement form.

**Practical activity**

**Role play:** Suppose you are a water purifier installation technician, after installation, list out the other document that has to be collected for installation of water purifier.

**Practical activity**

**Role play:** Suppose you are a water purifier installation technician, you have successfully installed the water purifier. Discuss the points that have to be informed to the customer care regarding the completion of job.

**Activity: Role Play**

Install a RO Water Purifier

**CHECK YOUR PROGRESS**

**Q1. Choose the correct option from those given below**

1. Which of the following is not the type of water purifier?
  - a) RO Water Purifiers
  - b) UF Water Purifiers
  - c) UV Water Purifiers
  - d) UAV Water Purifier
2. Which of the following is not the purification process of water purifier?

- a) Coagulation
  - b) Sedimentation
  - c) Filtration
  - d) Carbonization
3. Water treatment agent are classified as
- a) Chemical, filters, purifiers
  - b) Chemical, membrane, purifiers
  - c) Carbon, membrane, purifiers
  - d) Sedimentation, filters, chemical
4. Which of the following are not the types of common contaminants that are found in water?
- a) Bacteria
  - b) Minerals
  - c) Particulates
  - d) Protozoa
5. Which liquid is known as universal solvent
- a) Ethanol
  - b) Water
  - c) HCL
  - d) kerosene
6. What is the pH value of water.
- a) More than 7
  - b) Less than 7
  - c) Equal to 7
  - d) 14
7. Ice starts float on the surface of water because:
- a) Density of ice is lower than the density of water.
  - b) Density of ice is greater than the density of water.
  - c) Density of ice is equal to the density of water.
  - d) Density of ice is greater than equal to the density of water.
8. Which of the following is not the type of water purifier filter?
- a) RO water purifier



- b) UV water purifier
  - c) Gravity based water purifier
  - d) Carbon stone water purifier
9. Ensure waste water drain is within ..... form the water purifier.
- a) 3m
  - b) 4m
  - c) 5m
  - d) 6m
10. Ensure raw water supply tank is at least ..... above the purifier.
- a) 10 feet
  - b) 15 feet
  - c) 20 feet
  - d) 25 feet
11. Raw water TDS should not be less than .....
- a) 50 PPM
  - b) 100 PPM
  - c) 110 PPM
  - d) 120 PPM
12. Full form of TDS
- a) Total dissipated substance
  - b) Total dissolved solid
  - c) Total dissolved substance
  - d) Total dissipated solid
13. The average pressure for the purifier is 50-70 psi
- a) 70-80 psi
  - b) 60-50 psi
  - c) 50-70 psi
  - d) 40-50 psi
14. The water supply remains ON when the lever is parallel to SS ball valve body.
- a) ON
  - b) OFF

- c) ON or OFF
  - d) Water supply do not depend upon the SS ball valve
15. The water supply remains OFF when the lever is perpendicular to the SS ball valve body.
- a) ON
  - b) OFF
  - c) ON or OFF
  - d) Water supply do not depend upon the SS ball valve

**Q2. Fill in the blanks with correct word**

1. Water purification process in which transforming small particles to bigger particle .....
2. In ..... process of water treatment all the suspended particles are settling down at the bottom under the effect of gravity.
3. Purifier based on the principle of reverse osmosis is .....
4. UV water purifiers use ..... to kill all germs, bacteria and microbes dissolved in water.
5. In UV water purifier small mercury lamp is placed inside the purifier, which produces .....short wave UV radiations.
6. In water purifier installation raw water supply is within ..... from the water purifier.
7. To create a leakage free joint ..... used on the tap and pipe.
8. Purifier based on the principle of gravitational force of earth is .....
9. Disinfectants kill the ..... present in the water.
10. TFC/TFM is semi-permeable membrane used in the reverse osmosis (RO) water purification system.

**Q3. State whether the statement given below are true or false**

1. At the time of installation of water purifier sharp turns in the pipe fitting are avoided. ( )
2. Drill carefully two holes into the sticker making using the 8 mm drill bit. ( )
3. Stick the drilling sticker in a proper horizontal straight line. ( )
4. Temperature of the feed water must not exceed 100 F. ( )
5. Most RO systems come with particulate pre-filters to remove suspended particles down to five (5) micron in size. ( )

6. The temperature in this area should be maintained, and should not fall below 20 °F. ( )
7. Water treatment methods remove contaminants from the water to make it safe for human consumption. ( )
8. In purification process necessary vitamins and minerals of water are preserved. ( )
9. Gravity based water purifier works on the principle of reverse osmosis. ( )
10. Total dissolved solid level of raw water supply is approximately 974 PPM. ( )

**Q4. Short answer type question:**

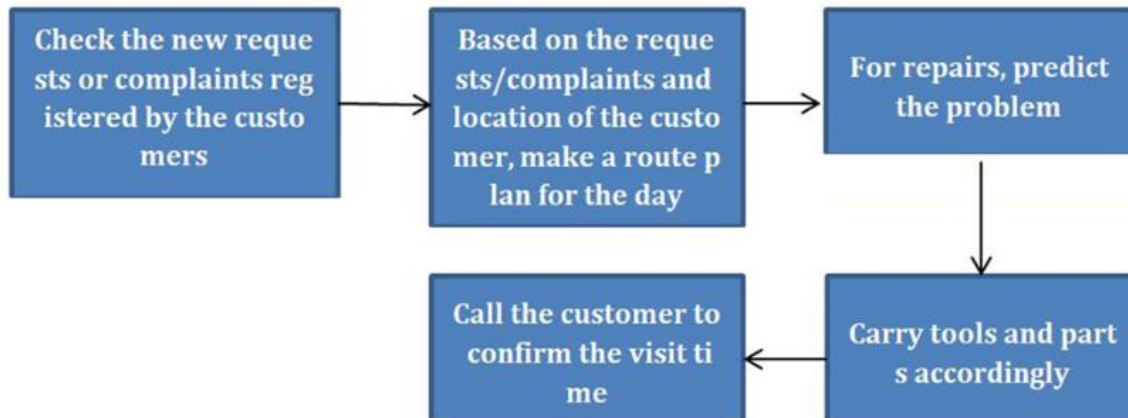
1. Write down the steps to replace the membrane.
2. List the type of water purifier.
3. Discuss the water purification process.
4. Write down the specification for power supply in the water purifier.
5. List the items present in the packing box of the water purifier.

**REPAIR AND MAINTENANCE OF WATER PURIFIER**

**5.1 UNDERSTAND THE SYMPTOMS**

**5.1.1 Identify the concerns of the customers**

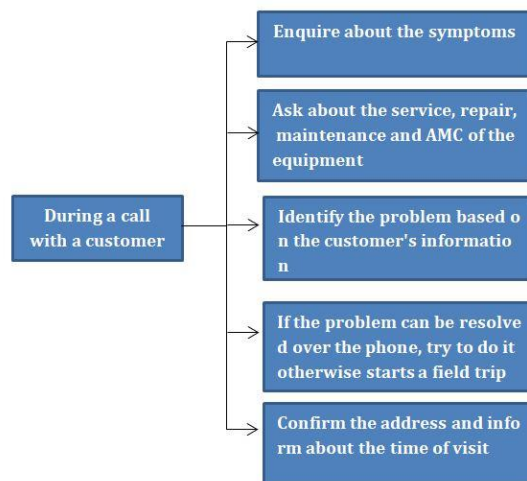
A field technician is responsible for the maintenance and repair of RO systems installed at customer’s premises. It is very important for her/him to clearly understand the concerns of the customer. The following figure represents the various activities which should be done before scheduling a visit to the customer’s premises:



*Fig.5.1: To- do list for a technician*

**5.1.2 Interact with the Customers on Phone**

Prior to visiting a customer’s premises for repairing/servicing, it is important to call the customer and ask about the problem in detail.



*Fig.5.2: Interacting with customer on Phone*

### 5.1.3 Interact with the Customer at their Premises

It is a good practice to be humble and respectful towards the customer. The following figure represents how to interact with a customer when visiting the premises for service/repair:



Fig.5.3: Interacting with customer

### 5.1.4 Identify the Fault

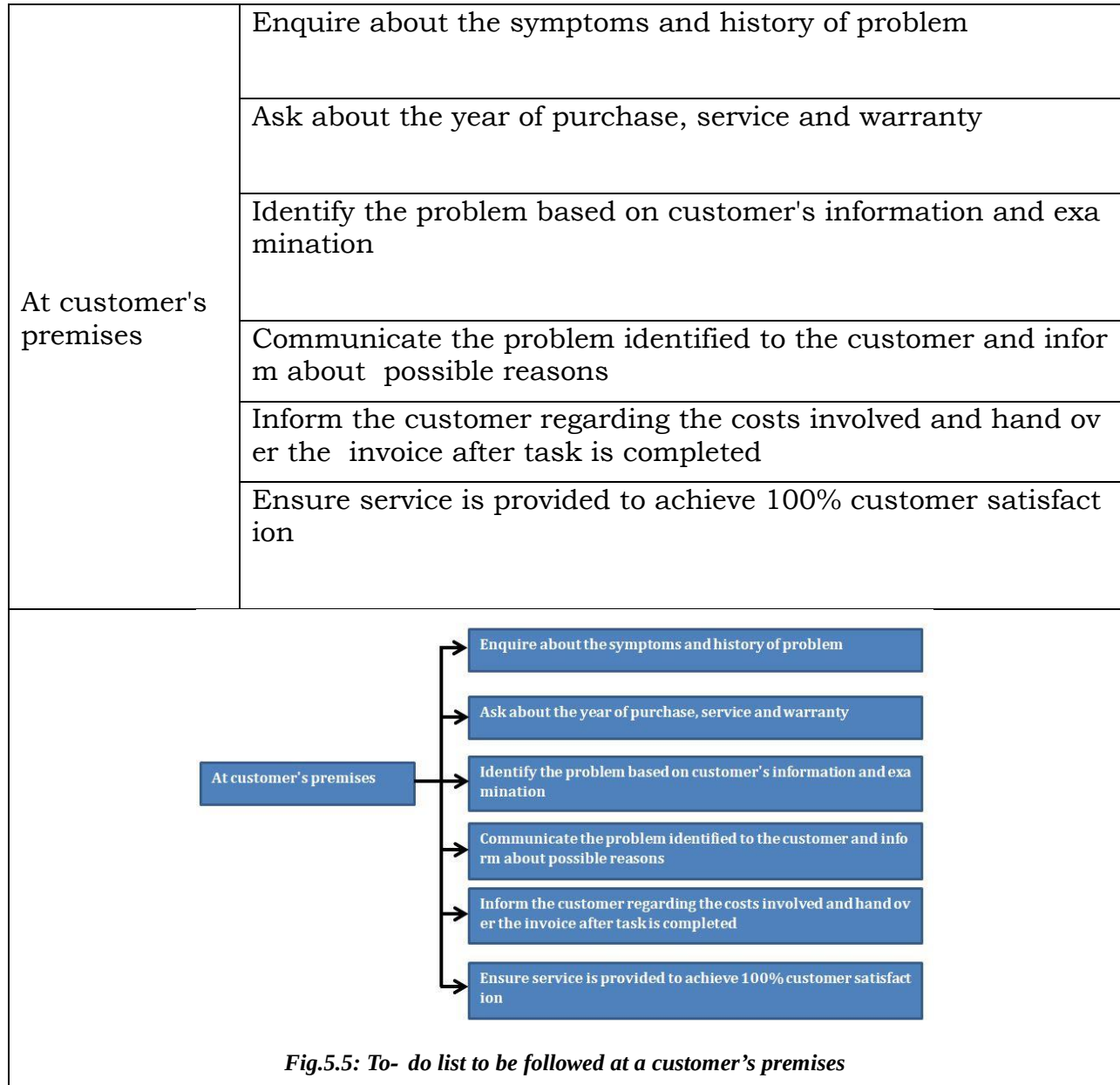
It is very important for a technician to identify the fault correctly. Wrong identification of fault will lead to wrong solution which will be waste of time and money and can also cause damage to the appliance.



Fig.5.4

When visiting a customer for a repair/servicing request, it is important to know the details of the problem and accordingly suggest a corrective measure. The customer should be satisfied with the suggested solution.

The following figure highlights the to-do list to be followed at a customer's premises:

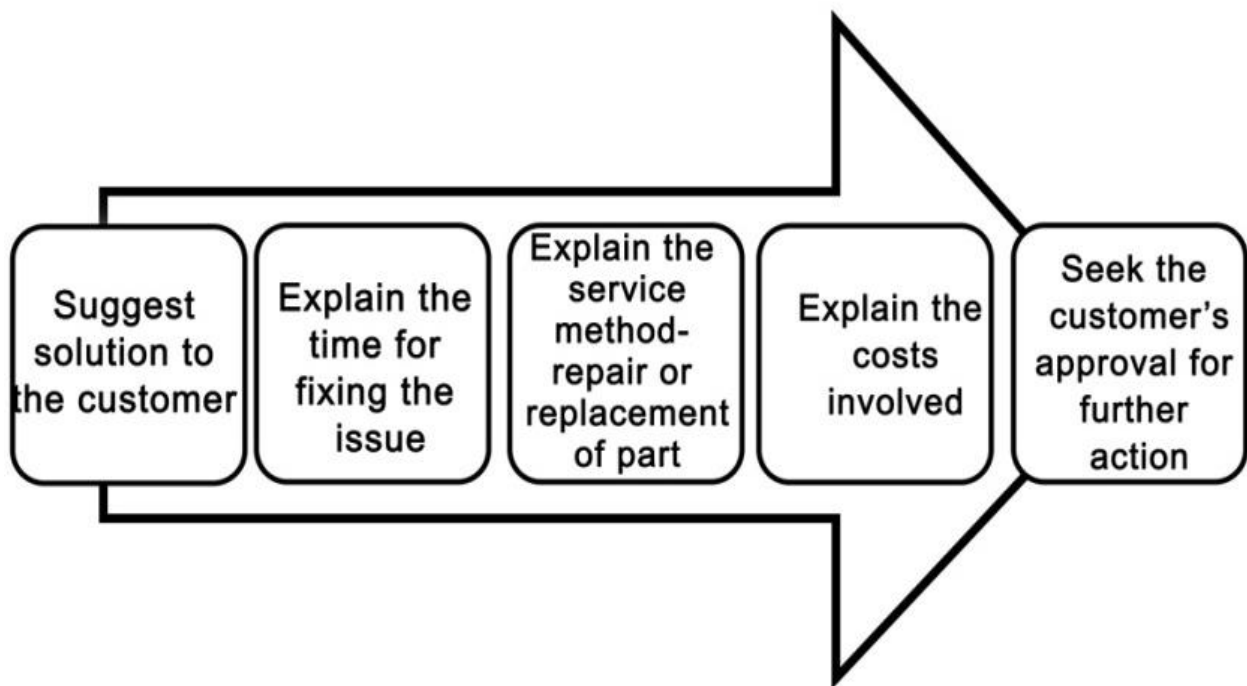


### 5.1.5 Suggest a Solution to the Customer

After identifying the issue, the field technician needs to offer solutions. She/He should explain all the possible solutions along with the cost associated. She/He should then propose the best solution and let the customer decide whether to go ahead with the given solution or not.

The following table shows the steps involved in offering solutions to a customer :

|   |
|---|
| 1. Suggest solutions to the customer                        |
| 2. Explain the time for fixing the issue                    |
| 3. Explain the service method repair or replacement of part |
| 4. Explain the costs involved                               |
| 5. Seek the customer's approval for further action          |



*Fig.5.6: Suggesting a solution to the customer for an issue*

**Activity: Role Play**

You are a home appliance repair technician. You just received a phone call from customer who is very angry for a poor service done by one of your colleague. She/he threatening to charge you of the bad service. How should the situation be handled?

**Practical activity:** Diagnose and list the fault based on customer interaction and initial inspection.

Following table define the common fault and diagnose of water purifier based on initial inspection and customer interaction.

| <b>Common fault</b>                              | <b>Diagnose</b>  |
|--|--|
| Problem of leakage                               | Check and tighten the joints of water purifier   |
| Increase in TDS level                            | TDS level can be decreased by replacing the membrane or by changing the filters  |
| Rise in water pressure                           | This can be diagnose by releasing the extra pressure using pressure regulator  |
| Interrupted power supply                         | Proper earthing is required for uninterrupted power supply   |
| Improper flow of water, Slowdown of water supply | This can be diagnosing by replacing filter or membrane, by maintaining the proper inlet flow of water in the water purifier. |

**Practical activity:** Demonstrate the steps for maintaining the water pressure as per company standards.

Following steps are implemented to maintain the pressure of the water supply:

Step1: Check the pressure of the inlet water supply using pressure gauge.



*Fig.5.7*



Step2: If reading in the pressure gauge exceeds the average value of water flow pressure.



*Fig.5.8*

Step3: Use the spanner to release the pressure of the water flow by un-screw the nut.



*Fig.5.9*

Step4: Again, check the pressure gauge note down the reading; make sure that it has reached the specified average value of the water flow pressure.



*Fig.5.10*

**Practical activity:** Demonstrate the steps for shut off the system by turning of water supply and unplug the unit.

Following points shows the shut off steps of the water purifier supply:

Step1: SS ball valve is use to control the flow of water in the water purifier.



*Fig.5.11*

Step2: The water supply remains OFF when the lever is perpendicular to the SS ball valve body.



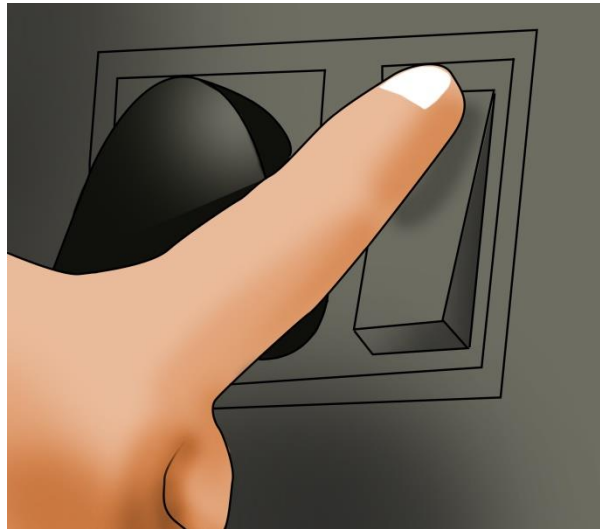
*Fig.5.12*

Step3: The water supply remains ON when the lever is parallel to SS ball valve body.



*Fig.5.13*

Step4: To unplug the unit remove the plug from the socket.



*Fig.5.14*

**Practical activity:** Discuss the points which should be followed in order to avoid spilling on the floor.

**Practical activity:** List the point which is to be considered while inspecting the feed water valve, and tank valve.

**Practical activity:** Separate and inspect every part of the unit if the fault is not identified through basic inspection

**Practical activity:** Visit and perform the identification of problem, for in depth knowledge technician must visit the un-identified problem, send to factory for in depth diagnosis.

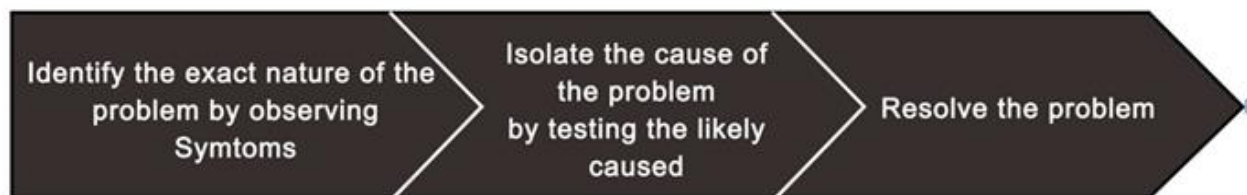
### 5.1.6 Replace dysfunctional part in the water purifier unit

#### a) Troubleshooting

Troubleshooting refers to repair of faulty products or processes. It begins with searching for the source of a problem and ends with finding the solution for that problem to ensure that the product or process functions properly. Good troubleshooting consists of the following four steps:

- Identification of the symptoms
- Elimination of the causes of a problem
- Verification of the solution
- Restoration of the product or process

The field technician should follow some simple steps for troubleshooting as shown in the following figure:



*Fig.5.15: Steps for troubleshooting*

#### b) Troubleshooting Chart

The following table lists some common problems and their solutions:

| Issue                         | Reason for fault                   | Solution              |
|-------------------------------|------------------------------------|-----------------------|
| Not Enough /No water from Tap | Blocked or closed feed water input | Open or unblock valve |
|                               | Blocked sediment/carb-             | Replace filters       |

|   |   |   |
|---|---|---|
|   | on filter                               |   |
|   | Closed tank valve                       | Open valve  |
|   | Blocked drain flow restrictor           | Replace drain flow restrictor   |
|   | Membrane housing valve stuck            | Replace check valve   |
|   | Malfunctioning automatic shut-off valve | Replace automatic shutoff valve   |
|   | Membrane polluted                       | Replace membrane  |
| Low pressure from water outlet tap/faucet | Incorrect air pressure in storage tank  | Empty storage tank<br>Pressurize the tank to 8 PSI<br>Reinstall the tank<br><br>Turn on the feed supply |
|   | Blocked post carbon filter              | Replace post carbon filter  |
|   | Partially closed tank valve             | Open valve  |
|   | Faulty faucet                           | Replace faucet  |
| High TDS in output water                  | Blocked pre-filter                      | Replace pre-filter  |
|   | Incorrectly sealed membrane             | Install the membrane correctly  |
|   | Exhausted membrane                      | Replace membrane  |
|   | Output and drain water lines reversed   | Swap the connections  |
|   | Malfunctioning automatic shut-off valve | Replace automatic shut-off valve  |
|   | Dirty post-carbon filter                | Clean/replace post-carbon filter  |
| Bad taste or odor                         | Blocked post carbon filter              | Replace post carbon filter  |
|   | Exhausted membrane                      | Replace membrane  |
|   | Dirty storage tank                      | Clean storage tank  |

|                             |   |  |
|-----------------------------|---|--|
|                             | Water in storage tank left for a long time    | Drain and clean storage tank   |
| Leaking membrane housing    | Leak in threaded end cap                      | Lubricate O-ring and tighten cap<br>Replace O-ring if leak continues                                   |
|                             | Leak in cap or body of housing                | Check housing/ cap for cracks<br>Replace if cracked or damaged   |
| Leaking filter housing      | Improper O-ring seating                       | Seat O-ring in groove<br><br>If dirty, clean and lubricate O-ring<br><br>Replace if cracked or damaged |
|                             | Housing cap loose                             | Hand tighten cap properly  |
|                             | Damaged housing                               | Replace if cracked or damaged  |
| Leaking fitting             | Damaged or cracked fitting                    | Replace fitting  |
|                             | Improper tubing or thread installation        | Check and correct tubing and thread installation   |
| System continuously running | Automatic shut-off valve not working          | Replace Automatic shut-off valve   |
|                             | Low incoming water pressure                   | Increase water pressure to 40 psi  |
|                             | Low air pressure in storage tank              | Increase air pressure to 5 - 7 psi when empty Damaged storage tank                                     |
|                             | Replace storage tank worn out flow restrictor | Replace flow restrictor  |
|                             | Incorrectly installed membrane                | Check membrane installation  |

|                    |                       |  |
|--------------------|-----------------------|--|
|                    | mbrane                | ion  |
| Milky way          | New System or filters | Air in lines - will go way with use              |
|                    | Water supply          | High oxygen content - will go way with use       |
|                    | Bad membrane          | Check TDS of water<br>Replace membrane           |
| Noisy drain/faucet | Air gap faucet        | Check air gap is properly installed              |
|                    | Drain tube            | Check drain line for loops, bends, dips or kinks |

**Activity: Identification Game**

A technician needs to take TDS measurement of a water sample? Fill in the blank steps to complete the procedure.

Steps1: Collect water in a \_\_\_\_\_

Steps2: Remove the \_\_\_\_\_ on

Steps3: \_\_\_\_\_ the water

Steps4: Lightly \_\_\_\_\_ the water to \_\_\_\_\_ any \_\_\_\_\_

Steps5: Wait for the display to \_\_\_\_\_

Steps6: Press the \_\_\_\_\_ to view the reading

Steps7: Remove the meter and shake off excess water  
\_\_\_\_\_ the cap

|  |
|--|
|  |
|--|

**Activity: Identification Game**

Match the RO system with the recommended duration for changing them.

|                             |                                |
|-----------------------------|--------------------------------|
| 1. Carbon post filter       | a. Changes every 6 – 12 months |
| 2. Reverse Osmosis membrane | b. Changes every 6 – 12 months |
| 3. Carbon filter            | c. Changes every 12 months     |
| 4. Sediment filter          | d. Changes every 24 months     |

**Practical activity:** The water purifier is giving low water pressure from dispensing faucet. How would you fix this?

**Equipment:** Wrench, Spanner

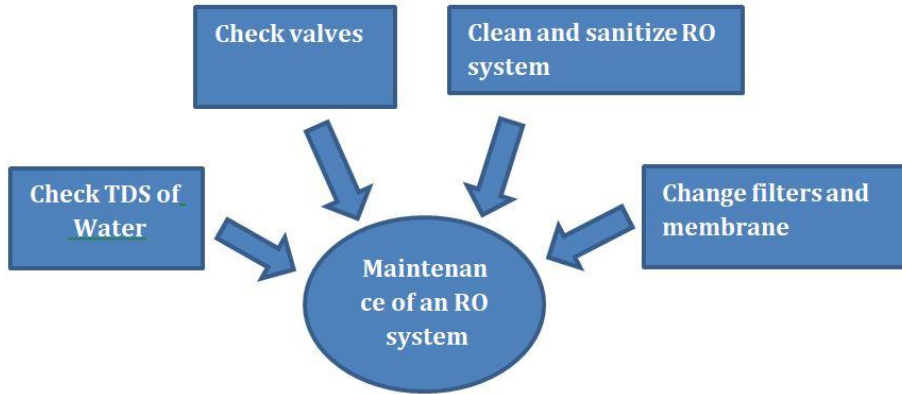
**Hints:**

- Empty the water from holding tank.
- Shut off feed water.
- Remove holding tank from under sink.

**5.2 MAINTENANCE OF RO WATER PURIFIERS**

To ensure that the water purifier provides the same quality water, it is essential to do periodic maintenance of the system. The following figure lists the components of the maintenance of an RO system:





**Fig.5.16: Maintenance of an RO system**

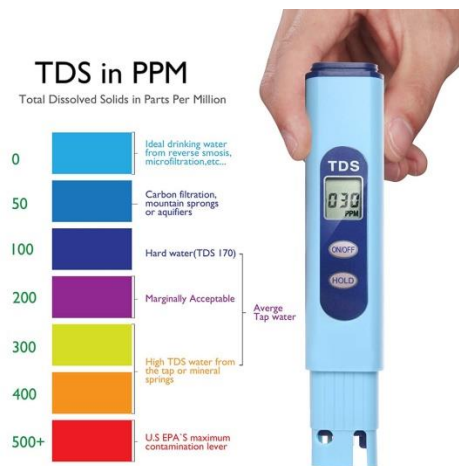
### 5.2.1 Check TDS of Water

Water is often called the universal solvent because it picks up impurities easily. The impurities can be minerals, salts, metals or ions and are also known as ‘Dissolved solids’. These dissolved solids increase the electrical conductivity of water. TDS is used as a measure to determine the purity of water and the quality of water purification systems.

#### a) Total Dissolved Solids (TDS)

Total Dissolved Solids (TDS) are the total amount of dissolved solids present in water. It is the sum of positively charged ions (cations) and negatively charged ions (anions) in the water. It is measured in units of mg per unit volume of water (mg/L) and is also referred to as parts per million (ppm).

The maximum contamination level advised for TDS is 500 mg /L and a high level of TDS indicate the possibility of toxic ions such as lead, arsenic, cadmium and others dissolved in water. The following figure shows the various levels of TDS in water:



**Fig.5.17: Levels of TDS in water**

It is important to monitor the TDS regularly to ensure that the water purification system is effective in removing unwanted particles from water. The following figure lists the reasons for testing water for high TDS:

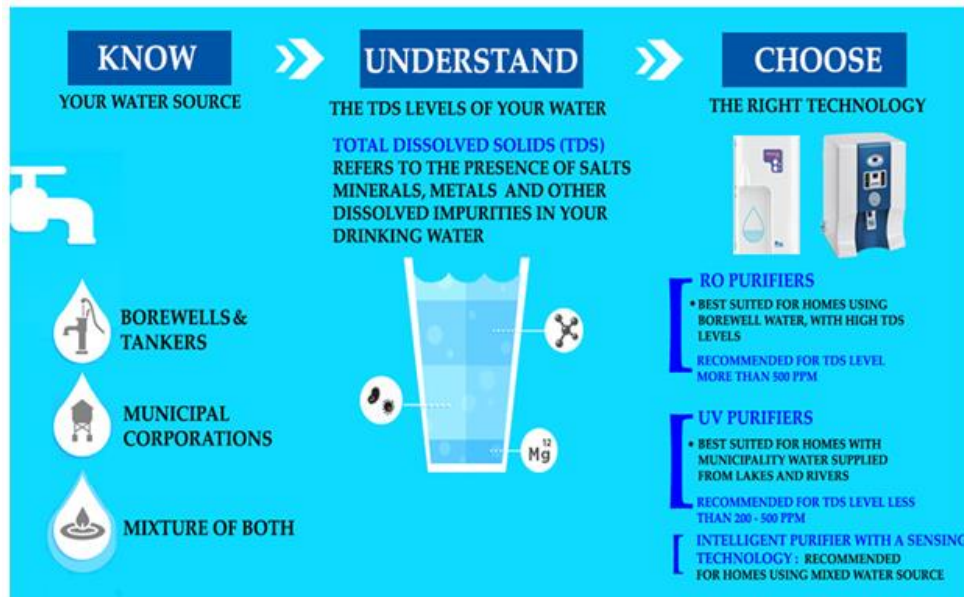


Fig.5.18: Reasons for testing water for high TDS

### b) TDS Meter

TDS of water or any solution is measured with the help of TDS meter. It is a small hand held device that measures the electrical conductivity of water and estimates the TDS from that reading. The following figure shows a commonly used TDS meter:



Fig.5.19: TDS meter

### c) Taking TDS Measurements

A TDS meter is very easy and simple to use. The following *figure* lists the steps of taking TDS measurements using a TDS meter:

- Step 1: Collect water in a clean glass
- Step 2: Remove the cap and turn the TDS meter on
- Step 3: Insert the meter into the water
- Step 4: Lightly stir the water to displace any air bubbles
- Step 5: Wait for the display to stabilize
- Step 6: Press the HOLD button to view the reading
- Step 7: Remove the meter and shake off excess water
- Step 8: Replace the cap

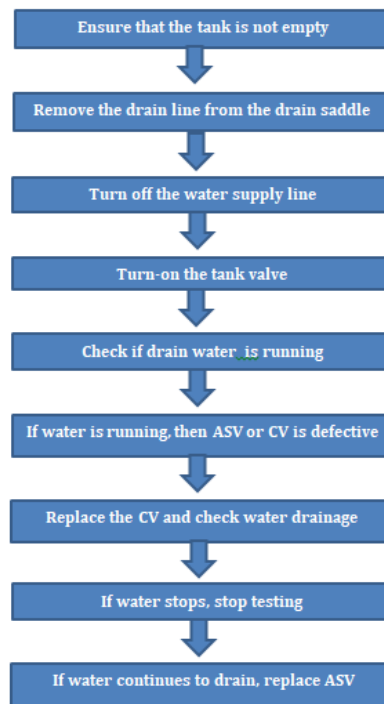


*Fig.5.20: Using a TDS meter*

### 5.2.2 Check valves

An RO system has two types of valves – Auto-shut-off valve (ASV) and check valve (CV). If either of the two is defective then the RO system will not shut-off and the water will be running constantly.

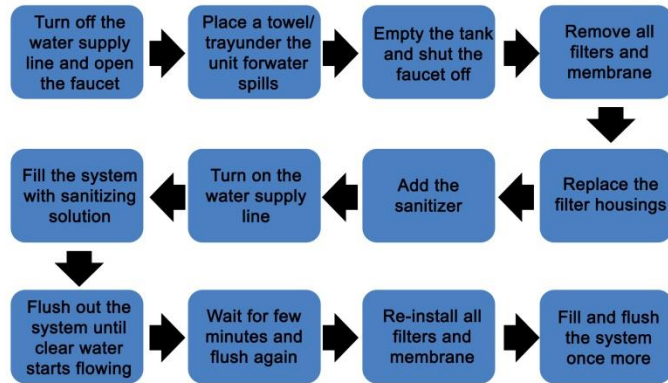
The following figure lists the steps involved in checking auto-shut-off valve and check valve:



*Fig.5.21: Steps to check valves of an RO system*

### 5.2.3 Clean and Sanitize RO System

An RO system should be cleaned and sanitized at least once every year. The steps to sanitize an RO system are listed in the following figure:



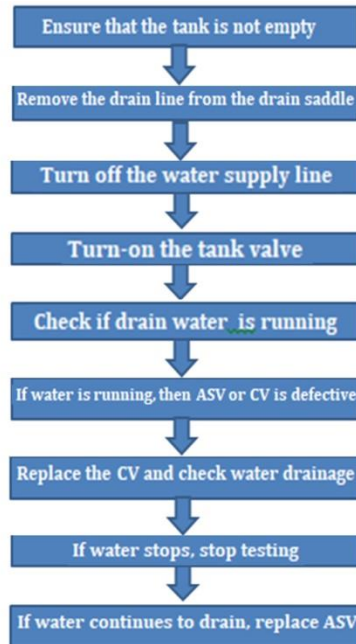
*Fig.5.22: Steps to sanitize an RO system*

### 5.2.4 Changing Filters and Membrane

It is recommended to change the filters/membrane of an RO system as per the following schedule:

| <b>Filter</b>          | <b>Duration</b>         |
|------------------------|-------------------------|
| Sediment filter        | Change after 6-12 month |
| Carbon filter          | Change after 6-12 month |
| Carbon post filter     | Change after 12 month   |
| Reverse osmosis filter | Change after 24 month   |

An RO system should be cleaned and sanitized at least once every year. The steps to sanitize an RO system are listed in the following figure:



*Fig.5.23: Sanitation and service procedures*

#### **a) Changing filter**

The following figure lists the steps involved in changing the filter:



*Fig.5.24: Steps of changing the filter*

#### **b) Changing Membrane**

Membrane is one of the filtering stages of purification. All membranes are shipped loose. They should be installed prior to start-up. They are also shipped dry to better handle extreme temperatures during shipment and storage.

- **Monitoring of membrane**

Membrane can be monitored by checking the TDS (Total dissolved solid) level of purified water. TDS meter is used for checking the TDS level in the water. TDS level chart is shown in table.... which represent the quality of water.

Table 1

| <b>TDS level</b> | <b>Water Hardness</b>             |
|------------------|-----------------------------------|
| 0-80 ppm         | Very soft (Ideal for drinking)    |
| 80-150 ppm       | Soft (might be used for drinking) |
| 150-400 ppm      | Hard (use RO purifier)            |
| Above 400 ppm    | Very hard ( use RO + UV purifier) |

Constant TDS level of water in the range 0-150 ppm is a good indication that RO water purifier is working properly. It is highly recommended to replace the membrane when the TDS level increase above 150ppm. For this reason, it is essential to monitor the TDS level of the purified water. The timing of membrane replacement depends on feed water quality and a number of other factors.

**Practical activity:** Demonstrate to replace the damaged components – membrane, filter, valve, water tank.

### **Replacement of membrane**

Following steps are used for the replacement of membrane in purifier:

- 1) To install membrane, unscrew the membrane housing by removing the blue clip as shown in *fig.*



*Fig.5.25*

- 2) Once the membrane housing is unscrewed, remove old membrane by pulling membrane upward using pliers if necessary as shown in *fig.*



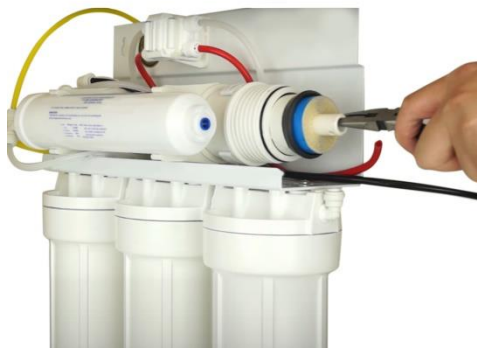
**Fig.5.26**

- 3) Install the new membrane by inserting it downward into the housings, with the seal at the top end of the membrane. Be sure to push each membrane as far down into the housing as possible, as shown in *fig.*



**Fig.5.27**

- 4) Make sure the black ring on the membrane must be at top end of the membrane housing as shown in *fig.*



**Fig.5.28**

- 5) When installing membranes, orientation of black ring must be proper.



Black ring do not fold over when inserting them into the membrane housings as shown in *fig.*



**Fig.5.29**

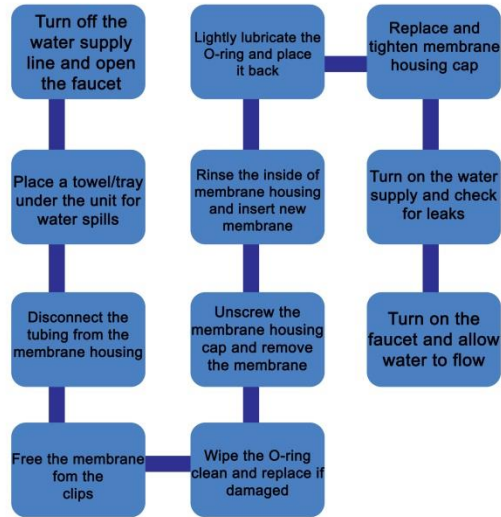
6) Now, again tighten the cap of the membrane housing using membrane wrench as shown in *fig.*



**Fig.5.30**

The following figure explains the steps involved in changing the membrane:





*Fig.5.31: Steps of changing the membrane*

### **Replacement of filter**

Following steps are used for the replacement of filter in purifier:

1. Turn off the feed water line using the SS ball valve.



*Fig.5.32*

2. Turn the SS ball valve off by turning the lever in perpendicular to the SS ball valve body.



*Fig.5.33*

3. Release the excessive pressure using the pressure release valve.



*Fig.5.34*

4. Put the wrench to first filter housing, open the housing by rotating the wrench in clockwise direction.



*Fig.5.35*

5. Remove the filter from the housing and discard the filter if necessary.

*Fig.5.36*

6. Put the new filter into the housing.



*Fig.5.37*

7. Ceramic filter is used in stage one and carbon black filter in stage two and three.



*Fig.5.38*

8. Before closing the housing make sure that every housing has a black O ring.



*Fig.5.39*

9. Tighten the housing by tighten the housing in the counter-clockwise direction.



*Fig.5.40*

### **Replacement of valve**

Following steps are used for the replacement of valve in purifier:

1. Turn off the main water supply.



*Fig.5.41*

2. Release the excessive pressure using the pressure release valve.



*Fig.5.42*

- Cut the water supply pipe using pipe cutter over which the SS ball valve has to be placed.



*Fig.5.43*

- SS ball valve has two ends having threads, one lever at the top to turn OFF or ON the supply.



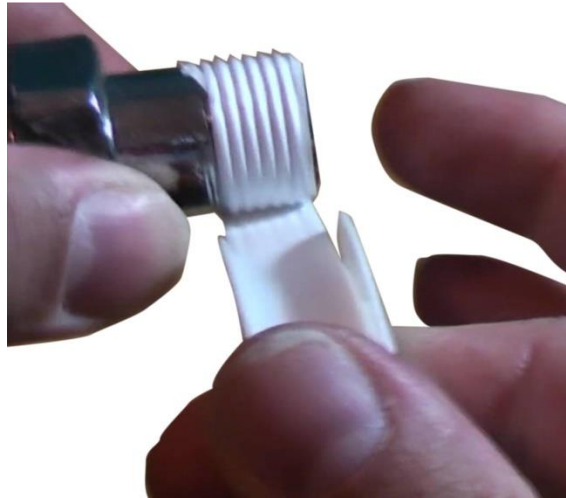
*Fig.5.44*

- Fit the SS ball valve at the appropriate place on the main water supply pipe.



*Fig.5.45*

6. Used thread tape for tightening the SS ball pipe.



*Fig.5.46*

7. After properly tighten the SS ball valve, turn the SS ball valve ON by turning the lever in parallel to the SS ball valve body.



*Fig.5.47*

8. Check for any leakage at the joint.



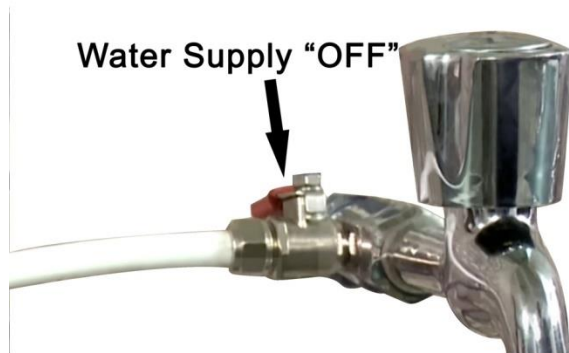
*Fig.5.48*

### **Replacement of water tank**

Water tank must be replaced when there is not enough air pressure in the water tank. As there is compressed air between rubber bladder and steel housing.

Following steps are used for the replacement of storage water tank in purifier:

1. Turn off the SS ball valve by turning the lever in the perpendicular position w.r.t to the SS ball valve body.



*Fig.5.49*

2. Release the excessive pressure using the pressure release valve.



*Fig.5.50*

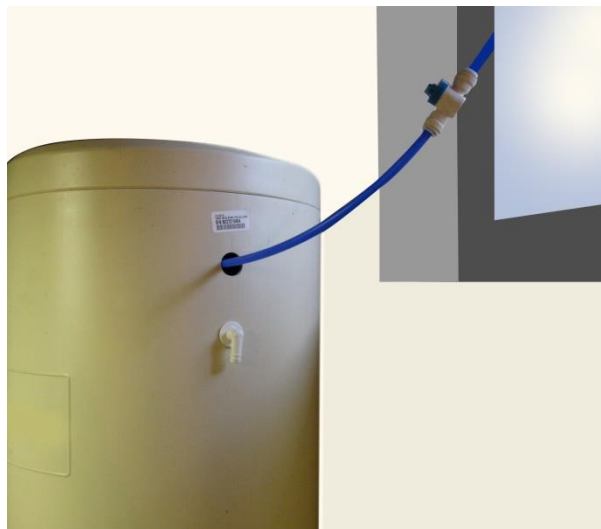
3. Disconnect the storage tank pipe using pipe wrench which is connected to the filter unit.





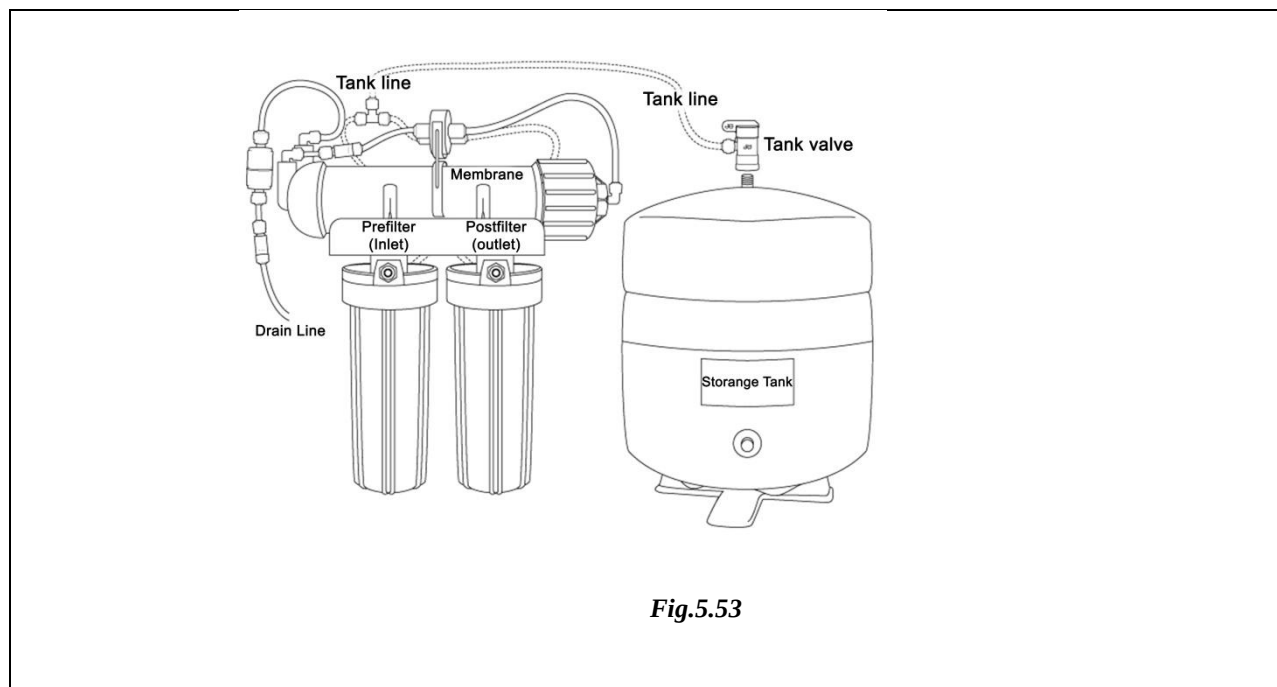
*Fig.5.51*

4. Wait for the water to flow out through the pipe of water tank.



*Fig.5.52*

5. Replace the water tank, connect the replace water tank to the filter unit using pipe wrench.



*Fig.5.53*

**Practical activity:** Discuss the steps for the maintenance of RO water purifier.

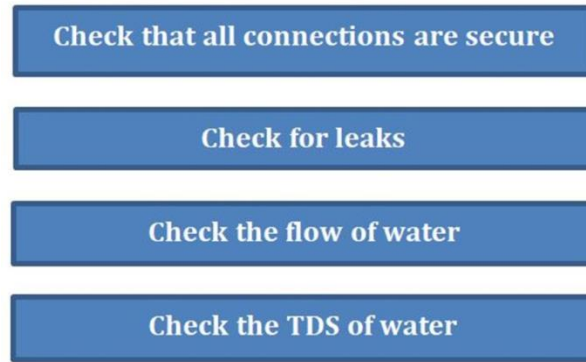
### **5.3 CONFIRM FUNCTIONALITY OF THE REPAIRED UNIT**

#### **5.3.1 Reassembling of components / module of the water purifier**

After detecting faulty component or module, these faulty components are replaced by new component or module. On completion of replacement of components / module reassembling of components / module is performed. Reassembling is the relocation of components /module at their respective place of same rating. Reassembling is a very critical task. All the components must be located at their respective place. Reassembling is performed via certain steps which are discussed in the practical activity.

#### **5.3.2 Confirmation of functionality of the repaired module**

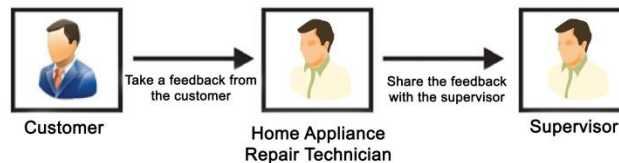
Once the purifier has been repaired, ensure that the unit is functioning properly with the repaired or replaced parts. The following figure lists the checks that should be performed after repairs are complete:



*Fig.5.54: Checks performed after repairs*

### 5.3.3 Take Feedback from Customer

The last step of understanding customer’s concerns is to take feedback from the customer as this is the most important thing for an organization. The procedure as shown in the following figure should be followed



*Fig.5.55: Procedure to be followed for taking customer feedback*

The time taken to resolve an issue and the difficulties that a customer encountered while communicating the problem should be understood. The misunderstandings observed during the interaction should be clearly documented. The methods of interaction and behavioral aspects also need to be considered in drawing conclusions after each task or problem handling routine. Getting honest feedback from the clients helps to improve the organizational functioning. The field technician can get a feedback form filled by the customer at the facility. The following *figure* shows a typical template for a customer feedback form:

**Customer Feedback Form**

Please fill the form. We value your feedback.

Date: \_\_\_\_\_ Location: \_\_\_\_\_

Service: Complaint  New Connection

1. How would you rate our service?

Very Good

Good

Poor

2. Did the technician come with all the necessary tools and equipment to do the job?

Yes  No

3. Did the technician behave politely with you?

Yes  No

4. Did the wireman have knowledge of the work to be done?

Yes  No

5. Any suggestion which you would like to share.

*Fig.5.56: A sample customer feedback form*

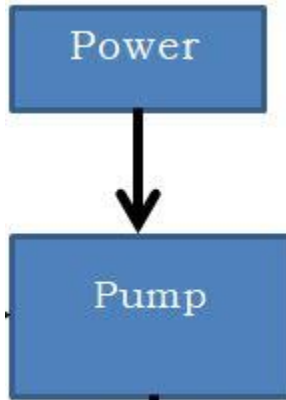
**Practical activity:** Demonstrate the steps for the reassembling the unit and Start the water supply and confirm the functioning.

RO+UV water purifier: Items in the assembly

1. Sediment filter
2. Pre carbon filter
3. Post carbon filter
4. Membrane housing
5. UV filter
6. Pump
7. Adapter
8. Water tank
9. Connecting pipe
10. Pipe Cutter

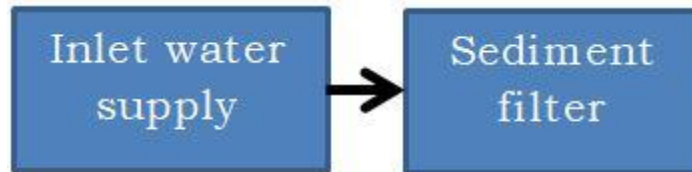
Following steps are used for the reassembling of RO+UV water filter.

1. Connect the output wire of adapter to provide the supply to the pump.



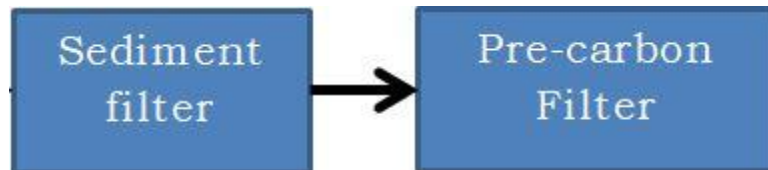
*Fig.5.57*

2. Connect the sediment filter which is connected to the inlet of the water supply.



*Fig.5.58*

3. Next, connect the inlet of pre-carbon filter to the outlet of sediment filter.



*Fig.5.59*

4. Outlet of the pre-carbon is connected to the inlet of pump.



*Fig.5.60*

5. Now, outlet of pump is connected to the inlet of membrane housing.

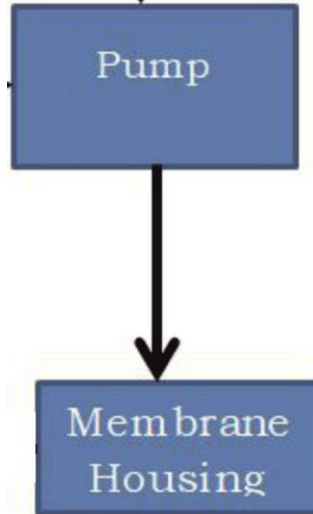


Fig.5.61

6. As membrane housing has two outlets, one is connected to the reject pipe through which waste water gets drained out, other outlet of membrane housing through which mineral water pass to next stage, which is the post carbon filter.

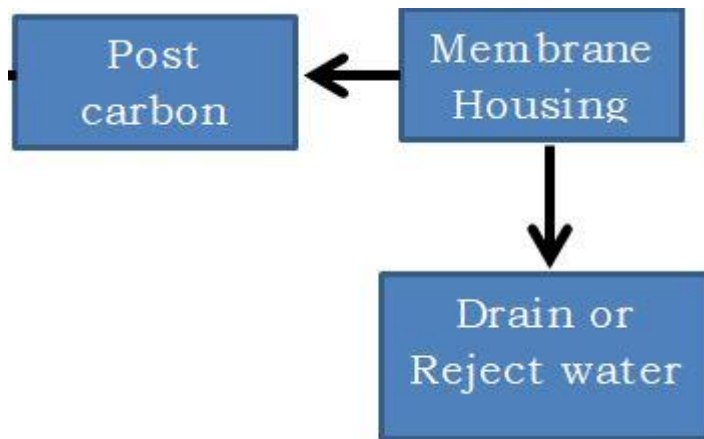


Fig.5.62

7. Outlet of post-carbon is connected to the UV filtration.

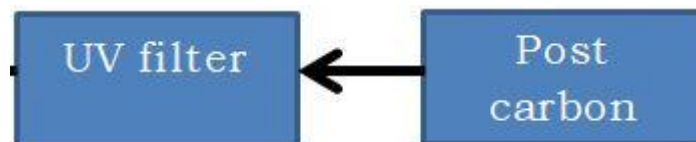


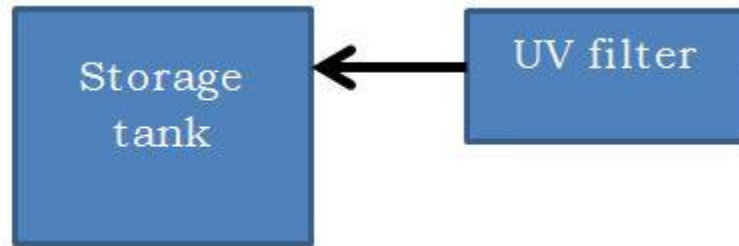
Fig.5.63

8. UV filtration is the last stage of the filtration process.



*Fig.5.64*

9. Outlet of the UV filter is connected to the inlet of water storage tank.



*Fig.5.65*

10. Connect the UV lamp power supply in the terminals of UV filter.

11. Now, start the water supply by turning the SS ball valve.



*Fig.5.67*

12. After turning 'ON' the water supply, feed water is enter into the sediment filter and from there on water pass through the different stage of filter as explained above.

13. Check for the proper functioning of different filtering stage, power supply, pump, UV lamp, SS ball valve etc.

**Practical activity:** Demonstrate and confirm functionality of the unit, Following steps are implemented to check the functionality of the water purifier.

1. Check for any leakage in the water purifier unit.
2. Read and note down the reading in pressure gauge.
3. If the reading of pressure gauge found greater than average value of predefined pressure of feeded water, then regulate the pressure of water flow by using pressure regulator.
4. Check the TDS level of the purified water using the TDS meter.
5. If the TDS level is higher than the recommended value, adjusted the TDS level of the purifier.
6. Check for the power supply and pump.
7. Check for the proper working of sediment filter, pre-carbon post, carbon filter, membrane housing, UV filter etc.

**Practical activity:** Demonstrate the cleaning procedures and other best practices.

Following steps are used for the cleaning of the purifier unit:

1. Clean the purifier after reassembling the purifier unit.
2. Clean the different filter of purifier.
3. Check for proper functioning of drainage system.
4. Clean the floor where water purifier is installed.
5. Regularly check the filter and membrane.

## **CHECK YOUR PROGRESS**

**Q1. Choose the correct option from those given below:**

1. Which of the following is not step of maintenance of RO Water Purifier?
  - a) Check TDS of Water
  - b) Check valves
  - c) Clean and Sanitize RO System
  - d) Draining of waste water
2. Which of following meter is used to measure the TDS level of the water?



- a) Multimeter
  - b) Clamp meter
  - c) TDS meter
  - d) Purifier meter
3. Where is the compressed air present in water tank?
- a) Between rubber bladder and steel housing
  - b) Between plastic housing and steel housing
  - c) Between rubber bladder and plastic housing
  - d) Between plastic bladder and plastic housing
4. Which form is filled by customer at the premises?
- a) Customer complaint form
  - b) Customer suggestion form
  - c) Customer acknowledgement form
  - d) Customer service form
5. Which of the following is type of impurity?
- a) Minerals
  - b) Salts
  - c) Metals or ions
  - d) All of the above
6. TDS greater than 500 ppm indicate the possibility of which of the following toxic ions:
- a) Lead
  - b) Arsenic
  - c) Cadmium
  - d) All of the above
7. PPM stands for.....
- a) Parts per meter
  - b) Particle per million
  - c) Particle per milli
  - d) Parts per million

**Q2. Fill in the blanks with correct word**

1. An RO system has two types of valves ..... and .....

2. An RO system should be cleaned and sanitized at least once.....
3. The maximum contamination level advised for TDS is ..... mg /L.
4. These dissolved solids increase the ..... conductivity of water.
5. Rise in water pressure can be diagnose by releasing the extra pressure using.....

**Q3. State whether the statement given below are true or false**

1. Improper O-ring seating causes not enough water from tap. ( )
2. Blocked post carbon filter causes bad taste or odor. ( )
3. Incorrect air pressure in storage tank causes low pressure from water outlet tap. ( )
4. Incorrectly sealed membrane causes high TDS in output water. ( )
5. Leak in threaded end cap causes leaking membrane housing. ( )
6. Dirty storage tank causes leaking filter housing. ( )
7. Damaged or cracked fitting causes leaking fitting. ( )
8. PPM stands for parts per million. ( )
9. Water will be soft if the PPM level is 80-150 PPM. ( )
10. Water will be very hard if the PPM level is above 400 PPM. ( )

**Q4. Match the column**

| <b>PPM</b>       | <b>Level of Hardness</b>             |
|------------------|--------------------------------------|
| 1. 0-80 ppm      | a) Hard (use RO purifier)            |
| 2. 80-150 ppm    | b) Very hard ( use RO + UV purifier) |
| 3. 150-400 ppm   | c) Very soft (Ideal for drinking)    |
| 4. Above 400 ppm | d) Soft (might be used for drinking) |

**Q5. Short answer type question:**

1. Write down the steps for maintaining the water pressure as per company standards.
2. Write down the steps for the replacement of valve.

3. Write down the steps for the replacement of filter.
4. What are the steps for checking the TDS level of the water?
5. Discuss the steps for reassembling the water purifier unit.

**6.0 INTRODUCTION**

Workplace hazardous system designed to protect the health and safety of workers. Information must be provided about the safe handling, use, storage, and disposal of hazardous. Workplace hazard is something that can have potential to harm the technician. There are hazards in every type of job and every type of workplace. Everyone at the workplace share the responsibility to identify and control hazards. Technician must first recognized workplace hazard at the workplace.

When technician install or assemble the components, she/he may have to face hazards which are related to workplace. These hazards are associated with the installation and assembly process of water purifier. Technician should be aware of the hazards associated with installation of water purifier. Many of the hazards can be avoided by being aware and taking appropriate precautions.

**6.1 HAZARDS RELATED TO WATER PURIFIER INSTALLATION**

Following points shows the hazards associated with the water purifier installation:

- Accident Hazards
- Physical Hazards
- Psychological, psychosocial and Organizational factors
- Chemical Hazards

|                         |   |
|-------------------------|---|
| <b>Accident hazards</b> | Falls, slips, and trips on the level on floors made wet and slippery during the handling of water.  |
|                         | Falls from ladder due to mounting the water purifier at height.   |
|                         | Electric shock caused by contact with “live” wires or defective electrical installations (the danger is especially high because the work is done in a wet and humid environment). |
|                         | Exposure to hazardous substances due to the sudden release of toxic materials as a result of an accident or human error.  |

|  |   |
|--|---|
|  | Fire hazard due to contact of a very strong oxidizer (disinfectant) with a flammable substance, as a result of improper storage of chemicals, human error.                                |
|  | When drilling from a ladder, do not try to overreach, this can cause the ladder to slide or tip. Never stand on the top step of a stepladder. Stand at least two steps down from the top. |

|                         |  |
|-------------------------|--|
| <b>Physical Hazards</b> | Exposure to high noise levels, from electro-mechanical equipment and a noisy environment.  |
|                         | Exposure to adverse weather conditions, risk of catching a cold as a result of working in windy weather, at low temperatures and while raining; or as a result of over-sweating in the summer; and suffering heat and/or cold strokes. |
|                         | Exposure to UV radiation during water disinfection may damage eyes and skin.   |

|   |   |
|---|---|
| <b>Psychological, psychosocial and Organizational factors</b> | Musculoskeletal injuries caused by awkward working postures during the cleaning/inspection of the pipe system and/or of the installation. |
|---|---|

|  |  |
|--|--|
|  |  |
|  | Overexertion while moving or handling heavy and bulky equipment or big packages of chemicals may affect various systems of the body. |
|  | Psychological stress and pressure due to environmental factors: annoying noise, water splashing, odors, high humidity, etc.          |
|  | Psychosocial problems due to increased workload, requirements of improving work output, constant need of high skill levels etc.      |

|                         |  |
|-------------------------|--|
| <b>Chemical Hazards</b> | If chemical are improperly stored causing a chemical leak.   |
|                         | If technician not taking any safety measure. These chemical may cause damage.  |
|                         | Mishandling of chemicals due to inadequate training or negligence.   |
|                         | Diseases and environmental illnesses that can be caused by exposure to toxic substances in the workplace.  |
|                         | After a person has been exposed to chemical hazards in the workplace, Some of the symptoms of exposure to toxins can include: <ul style="list-style-type: none"> <li>• Chemical burns</li> <li>• Itchy burning eyes</li> </ul> |

|  |   |
|--|---|
|  | <ul style="list-style-type: none"> <li>• Nausea, vomiting and diarrhea</li> <li>• Headaches</li> <li>• Fever or chills</li> <li>• Rapid heart rate</li> </ul> |
|--|---|

## **6.2 POSSIBLE ERRORS DURING CLEANING THE FILTERS**

Following points defines the error in cleaning the filters:

1. Cap of the filter housing is not properly tightened.
2. O-ring is not present in the filter housing, this will result in leakage.
3. While replacing the membrane, it should be correctly inserted in the filter housing.
4. While reassembling the filter unit, filter sequence is not followed properly i.e. sediment filter, pre-carbon filter, post-carbon filter, membrane are not connected in proper sequence.

## **6.3 ELECTRICAL HAZARD**

An electrical hazard defines a dangerous condition. This dangerous condition related to energized equipment or a conductor at workplace. If technician comes in contact with these energized equipment, these equipment may injured the technician. There is a possibility of getting the shock or receive an arc flash burn, thermal burn, or blast injury. When assembling the components in a unit. Many of the hazards can be avoided by being aware and taking appropriate precautions. This will ensure safety at workplace. Points which may result to electrical hazard are as follows:

- Exposure to high electromagnetic fields.
- Electrical fires due to improper and out-dated wiring and faulty outlets.
- Electric shock due to improper grounding or earthing of electrical equipment.
- Defective or inadequate insulation on electrical cables.

To avoid electrical hazards, follow the precautions such as:

- Ensure the power tools to be used in the assembly process include extension cord of proper rating.
- Do not use damaged electric tools.
- Inspect and test the installed electrical equipment and system at a regular interval.
- Check the rating and physical condition of the components and cables.
- Use the standard techniques for assembling the components.
- Use protective equipment for safety purpose.

## 6.4 ELECTRICAL RESCUE TECHNIQUES

### 6.4.1 Approaching the accident place

- Never rush into an accident situation.
- Call 108 as soon as possible.
- Get the aid of trained electrical personnel if possible.
- Cautiously approach the accidental place.

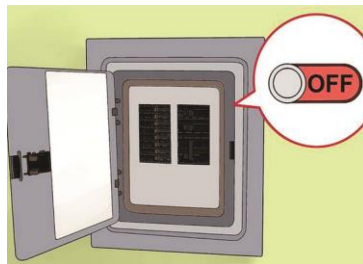
### 6.4.2 Examining the accident place

- Visually examine victims to determine if they are in contact with energized conductors.
- Metal surfaces, objects near the victim or the earth itself may be energized.
- Do not touch the victim or conductive surfaces while they are energized. Else you may become a victim if you touch an energized victim or conductive surface.



*Fig.6.1*

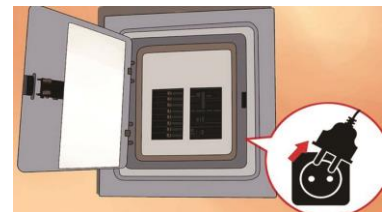
- De-energize electrical circuits if at all possible.



*Fig.6.2*

### 6.4.3 Methods to de-energize

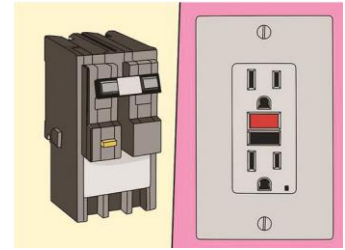
- An extension or power cord probably powers portable electrical equipment. Unplug portable electrical equipment to remove power.



*Fig.6.3*



- De-energize fixed electrical equipment by using circuit breaker or by disconnecting the device.



**Fig.6.4**

### 6.4.4 Hazards and solutions

Following points illustrate the cause of hazards:

- Be alert for hazards such as stored energy, heated surfaces and fire.
- Technician or person must be more cautious, if the power source cannot be de-energized.
- Ensure that hands and feet are dry.
- Wear protective equipment such as protective gloves, rubber shoes etc.



**Fig.6.5**

- Stand on a clean dry surface.



**Fig.6.6**

- Use Insulating material to remove a victim from the conductor.



**Fig.6.7**

### 6.4.5 High voltage rescue

- Working with high voltage requires special training for rescue.



**Fig.6.8**

- Protective equipment such as high voltage gloves and overshoes must be used.



**Fig.6.9**

- Highly insulated tools should be used.



**Fig.6.10**

#### 6.4.6 Insulated tools

- Insulated tools are lifesaver.
- These tools must have high voltage rating.
- Use wooden stick to remove a victim from energized conductors.
- In some cases, nonconductive rope or cord may be used to remove a victim from a conductor.

#### 6.4.7 Rescuing the victim

- Stand on a dry rubber mat or other insulating material if possible.
- Do not touch the victim or conductive material near the victim until the power is off.
- Once power is off, examine the victim to determine if they should be moved. Give “First Aid.”

#### 6.4.8 First Aid

- A victim may require Cardio-Pulmonary Resuscitation (CPR) or artificial respiration.
- If the victim is breathing and has a heartbeat, give first aid for injuries and treat for shock.
- Ensure the victim gets medical care as soon as possible.
- Provide medical personnel with information on voltage level, shock duration & entry/exit points. The treating/attending physician must have detailed specific information to properly diagnose and care for the victim.

### 6.5 HAZARD DUE THE TOOLS

The following list of tools does not include all the tools . When introducing any tool, technician should follow the points to using tools and equipment safely.

#### 6.5.1 Hand drill

A hand drill is a small hand-operated drill. It is used to bore holes in materials. Handle operates a gear mechanism that turns a drill bit. Hand drills are safe enough for technician to use if the follow safety procedures.



**Fig.6.11**

| Hazard  | Precaution  |
|---|---|
| Hair and clothing can become caught in the drill          | Don't wear loose dress and cover hairs while drilling   |
| Dust and particles can enter eyes while drilling          | If there is a risk of dust or particles getting into eyes, technician should wear safety glasses or goggles.  |
| Work can injure hands if it catches in the drill and spin | Always secure the material to be drilled to the workbench using clamps or a vice. Place scrap wood underneath the material so the drill can pass through without damaging the work surface.               |
| The drill bit can snap due to excessive force             | Warn students not to force the drill bit. They should drill at a speed suited to the materials and the size of the drill. Smaller drills can be rotated at a faster speed. The drill bit should be sharp. |
| The drill bit and work being drilled will become hot      | Allow time for the drill bit to cool between uses.  |

### 6.5.2 Tap and dies

Taps and dies are used to create a thread in metals.



Fig.6.12

| Hazard   | Precaution   |
|--|--|
| Punching out a broken tap can cause fragments to be propelled into eyes. | Students must wear safety goggles or a face shield when punching out a broken tap. |
| Sharp threads and metal fragments can cut hands.                         | Students should avoid handling fragments and cut the thread slowly.                |

### 6.5.3 Pliers

Pliers come in a variety of shapes and sizes, each with a different function. Their main purpose is to bend, hold or curve metal. They are also used to hold materials or components while soldering or hammering and as a heat sink in electronics. Combination pliers have jaws for gripping and cutting a section. They are suitable for primary students to use.



Fig.6.13

| Hazard   | Precaution   |
|--|--|
| The main hazard is pieces of wire shooting off when cut. | Students should wear safety glasses, if the processes used could cause small pieces to be propelled into eyes. |

### 6.5.4 Screwdrivers

A screwdriver is used to tighten and loosen screws. There are two types – slotted head and Phillips head. Slotted head screwdrivers have a flat-edge blade that fits into the slot on a screw. Phillips head screwdrivers fit into the cross-shaped screw heads. Choice of screwdriver will depend on the screw.



**Fig.6.14**

| <b>Hazard</b>  | <b>Precaution</b>   |
|--|---|
| Screwdrivers can be hazardous, if used for the wrong purpose.  | Do not use a screwdriver as a cold chisel, punch or to open joints.   |
| The point of a screwdriver can cause an injury if carried incorrectly.   | Students should carry screwdrivers with the point facing down.  |
| Screwdrivers can break suddenly if used with force.  | Do not use excessive force to turn a screw.   |
| Screwdrivers can slip if used incorrectly.   | When choosing a screwdriver, ensure the tip edges fit neatly in the screw slot. Soap can be used to help the screw enter materials more easily. Students should keep their free hand away from the blade. |
| The metal of the screwdriver can conduct electricity, causing an electric shock if it contacts a live surface. | Insulated screwdrivers should be used in electronic activities.   |

### **6.5.5 Spanners and wrenches**

Spanners and wrenches are designed to turn different types of nuts and bolts. . Spanner generally refers to a tool that turns nuts and bolts, while wrench refers to a tool that grips cylindrical work. Ensure that students know how to choose suitable spanner for their task.



Fig.6.15 (a)



Fig.6.15 (b)

| Hazard  | Precaution  |
|---|---|
| The spanner slipping can injure the student, or damage the nut or the spanner | The spanner should fit the nut or bolt firmly.  |
| Spanners can break suddenly and break if used with excessive force.           | Do not allow students to strike a spanner with a hammer. Apply pressure by hand only. |

### 6.5.6 Hammers

A variety of hammers are used in technology. Some are used with metal (ball peen), others with wood (claw). Hammers pose a number of hazards. Ensure that technician use hammers suitable for their job.



Fig.6.16

| Hazard  | Precaution   |
|---|--|
| Loose heads can fly off while in use.                                     | Warn students never to use a hammer with a loose head and not to hit hammer faces together. They should check hammers before using them. |
| The item being hammered can chip and pieces fly off. Nails can fly out of | Students should wear safety glasses when using hammers.  |

|   |  |
|---|--|
| materials when using a claw hammer to remove them.              |  |
| Hammers can fall if not used or carried properly.               | Hold the hammer tightly by its handle  |
| Hands can be injured if near the point of impact of the hammer. | Technician should properly hold materials to avoid injury. Secure work with a clamp or vice hold the object with pliers. |
| Hammers pose a noise hazard when striking tools or materials.   | Use ear protection wear to protect the ears.   |

### 6.5.7 Soldering irons

A soldering iron has a pointed copper head attached to a steel rod with a wooden handle. It is used for soft soldering, a technique where soft solder is heated and used to join metals. Note: Lead-free solder can be used with electric soldering irons.

**Fig.6.17**

| <b>Hazard</b>   | <b>Precaution</b>   |
|---|---|
| Heated soldering iron can cause burns or damage work surfaces.  | Technician should position hot soldering irons on a heatproof surface.  |
| Fluxes and solders can be hazardous<br>Solder and flux fumes may contain lead or other substances harmful if inhaled. | Soldering irons must be used in a well-ventilated area. Technician should avoid skin contact with solders and fluxes and wash hands after use. Cotton gloves can be used. |
| Solder fumes can affect eyes.   | Students should wear safety glasses when using soldering irons.   |

**Practical activity:** List the safety precautions to be observed while installing,



repair and maintenance.

**Practical activity:** List the safety rules, policies and procedures.

**Practical activity:** Demonstrate the packaging waste and its disposal

Following points represents the packaging waste and its disposal:

1. During unpacking of water purifier, the box of purifier must be disposed in the dustbin.



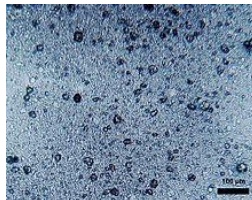
**Fig.6.18**

2. During the unpacking of filters, box of purifier must be dispose in the dustbin.



**Fig.6.19**

3. While installing the filter, small pieces of the particles coming out from filter. These may get scattered on the floor. They must be properly cleaned otherwise they may damage the skin of the customer and technician.



**Fig.6.20**

4. Water which is been drained out of the purifier can be utilized.



**Fig.6.21**

5. Drained water can be utilized for gardening, floor cleaning, for washing clothes etc.

**Practical activity:** List the hazards during repairs.

### **CHECK YOUR PROGRESS**

#### **Q1. Choose the correct option from those given below**

1. Which of the following tools is used for making threads?
  - a) Tap and dies
  - b) Screwdriver
  - c) Hammer
  - d) Drill machine
2. Which of the following tools is used for making holes on the wooden and wall?
  - a) Screwdriver
  - b) Drill machine
  - c) Plier
  - d) Wrench
3. Which of the following tools is used for cutting bending of wire?
  - a) Screwdriver
  - b) Soldering iron
  - c) Plier
  - d) Wrench
4. Which of the following tools is adjustable tool for unscrew the sanitary pipe?
  - a) Screwdriver

- b) Soldering iron
  - c) Wrench
  - d) Plier
5. Which of the following tools is used to turn different types of nuts and bolts?
- a) Hammer
  - b) Soldering iron
  - c) Plier
  - d) Spanner
6. Which hand tool is used to convert the metal into thin sheet (malleable)?
- a) Screw driver
  - b) Hammer
  - c) Wrench
  - d) Spanner
7. Which hand tool is used to connect the two metal wires?
- a) Hammer
  - b) Soldering iron
  - c) Wrench
  - d) Spanner
8. Cardio-Pulmonary Resuscitation is a ....
- a) Natural respiration
  - b) Artificial respiration
  - c) Study of respiratory system
  - d) Study of heart
9. ....pliers have jaws for gripping and cutting a section.
- a) Combination plier
  - b) Wrench
  - c) Solder iron
  - d) Screwdriver
10. Handle of a tool must be made up of ..... material.
- a) Conductor
  - b) Insulator
  - c) Semiconductor

d) All of the above

**Q2. Fill in the blanks with correct word**

1. While working on electricity, the technician must wear ..... gloves and shoes.
2. Keep stretching your arms, legs, neck and back while working to ensure that they are not .....
3. The unconsciousness due to electric shock may cause damage to his/her.....
4. In case of electric shock, a child or infant should give a pressure of .....
5. Exhale the breath from your mouth into the nose of person slowly so that air enters his.....
6. One of the causes of electric shock may be to improper ..... of electrical equipment.
7. Defective or inadequate insulation may result .....
8. Faulty current can be transfer to ground using .....

**Q3. State whether the statement given below are true or false**

1. Circuit breaker is used to protect the circuit from faulty and large current flowing through an appliance.
2. Fire extinguishers for use on electrical fires will have a C, BC or ABC on the label.
3. Artificial Respiration is Cardiopulmonary Resuscitation.
4. Fire extinguisher consists of a hand-held cylindrical pressure vessel containing an agent which can be discharged to extinguish a fire.
5. Common injuries that can be caused due to lifting heavy loads include back ache, neck strain, wrist sprain, back sprain, shoulder pain.
6. The aim of first-aid treatment is to cool down the affected area rapidly to minimize damage and loss of body fluids, and therefore reduce the risk of developing shock.
7. Rubber is a good conductor of electricity.
8. Fire extinguisher is used in case of an earthquake.
9. Copper is a good conductor of electricity.
10. Earthing is necessary in electrical equipment.

**Q4. Short answer type question:**

1. What are the factors that result in hazard?

2. List out the various remedies to be taken in workplace.
3. What are the precautions to be taken for preventing electric shock on the job?
4. How to perform artificial respiration?
5. How will you reduce the risk associated with handling of heavy and hazardous loads?